

UNIVERSITY DESIGN GUIDELINES



Fourteenth Edition – December 2024



FORWORD

Every three years the University of Virginia updates the Design Guidelines for buildings on Grounds. Regular suggestions from the previous three years are coupled with those that come from a formal *Call for Comments*. The result is usually several hundred ideas for additions, subtractions, and improvements to the Design Guidelines, which are weighed and evaluated in an open process similar to the development of building codes.

This year’s 14th Edition represents the 40th anniversary of Design Guidelines at the University. The 1st Edition was titled *Facility Design and Construction Guidelines* and was prepared specifically to assist design consultants, contractors, and in-house staff in the “planning, construction, and renovation of University facilities.” It was formatted to align with the Construction Specifications Institute Unifomat and was nearly 250 pages in length. Published in 1984, the Guidelines also contained procedural and procurement information that would later form the basis of the Higher Education Capital Outlay Manual (HECOM).

A dozen years later the 4th Edition was narrowed to focus specifically on design requirements for architects and engineers. Contracting requirements were moved into HECOM. The Guidelines were reformatted into a series of categories – Substructure, Building Envelope, Interiors, Services, etc – which reduced the document’s overall length. The Chief Facilities Officer and the Architect for the University were signatories to the 4th Edition with members of the Building Official serving as editors. Over the next twenty years this general format remained, and the Guidelines grew to more than 300 pages!

A comprehensive edit and reformat was undertaken in 2014 with the 11th Edition. Following the University’s first Sustainability Plan in 2016, Green Building standards were consolidated into an appendix and included in the 12th Edition. The 13th Edition expanded and moved the Green Building standards to Chapter 8, reflecting an increased commitment by the University toward the goals of carbon neutrality by 2030 and being fossil free by 2050.

The current edition contains numerous updates and improvements. The Office of the Architect (OAU) released new *Signage & Wayfinding Guidelines* to provide visual consistency and clarity to the public while on Grounds. OAU also updated their *Landscape Typologies & Standards*. The Office for Sustainability created the *Waste Infrastructure Requirements* with a goal of reducing UVA’s waste by 70%. Each of these documents are referenced throughout Guidelines and are linked on OUBO’s website. Finally, this 14th Edition includes an update to the name, now the *University Design Guidelines*, to reflect its broad body of stakeholders as well the breadth of its design impact.



Benjamin Hays, PE, CBO, LEED AP
University Building Official



Alice Raucher, FAIA, AUA, LEED AP
Associate Vice President &
Architect for the University



Donald Sundgren
Associate Vice President &
Chief Facilities Officer



INTRODUCTION

The University Design Guidelines (UDG) are intended to be used by architects, engineers, and designers involved in the preparation of construction documents for the University of Virginia. The Guidelines also serve as a reference for University project managers, construction managers, and maintenance teams whose responsibilities relate to construction, renovation, and maintenance work at UVA. They are meant to apply institutional lessons-learned from the design, construction, operation, and maintenance phases of a building's life.

This Fourteenth Edition of the Design Guidelines has been updated to reflect current design and construction practices as well as the needs of the University for efficient and well-designed buildings. In making this update, several hundred suggestions from around and outside of the University were considered. Previous requirements were reevaluated to determine their continued applicability. Major changes in this edition include an update to the name, a change in the primary accessibility standard, the creation of the waste infrastructure standards, updates to signage standards, and a compilation of external references that is now available on OUBO's webpage. Discipline-specific changes, like new criteria for lightning protection, occur throughout the document and are listed in a change log posted on OUBO's webpage.

The Guidelines provide procedural and technical requirements that are broadly applicable to all design and construction on UVA's Grounds. As part of the contractual agreement between design professionals and the University, conscientious application of the Guidelines is a tool to expedite the design and construction process in a cooperative, partnering manner. The requirements of the Guidelines are intended to be incorporated into design documents and constructed buildings and shall be followed for all University projects. If projects have truly unique circumstances that warrant a waiver or an alternative to the Guidelines, consideration can be given via the Determination and Findings process.

Requirements found within the Virginia Uniform Statewide Building Code (VUSBC) and its referenced standards are not repeated within these guidelines. The VUSBC is applicable to all University of Virginia buildings without exception. If any part of these guidelines unintentionally conflict with current or future VUSBC or other state or federal regulations, the most restrictive requirements apply.

Recommendations are always welcome for simplifications, additions, and modifications to the Guidelines. Please email suggestions to udg-suggestions@virginia.edu and they will be considered with the next edit.

Benjamin Hays, PE, CBO, LEED AP
Managing Editor

OUBO Editorial Team:

Christopher Barfield, PE
Natalie Feaver, AIA
Katherine Grove, AIA, CBO
Rachelle Hermes, PE
David Jones, PE
Nathan Lawson, PE
Peter Mackey, PE
Robert Waite, AIA, CBO
Caitlin Walls

TABLE OF CONTENTS

CHAPTER 1 GENERAL REQUIREMENTS	1
1.1 GENERAL INFORMATION	1
1.1.1 DEFINITIONS/TERMS	1
1.1.2 DOCUMENTS	1
1.1.3 LIFE SAFETY DRAWING STANDARDS FOR ALL PROJECTS	2
1.2 CODES, UVA REVIEWS, PERMITS	2
1.2.1 GENERAL REQUIREMENTS	2
1.2.2 REVIEWS AND APPROVALS	5
1.2.3 PERMITS	6
1.3 SITE PLANNING REQUIREMENTS	7
1.3.1 GENERAL REQUIREMENTS	7
1.3.2 STORMWATER MANAGEMENT / EROSION & SEDIMENT CONTROL	8
1.3.3 ENVIRONMENTAL IMPACT REPORTS [EIR]	10
1.4 BUILDING PLANNING REQUIREMENTS	10
1.4.1 GENERAL REQUIREMENTS	10
1.4.2 SPACE PLANNING	10
1.4.3 SECURITY	11
1.4.4 HAZARDS	17
1.4.5 REQUIREMENTS FOR SPECIFIC USES	20
1.4.6 BUILDING DEDICATION PLAQUES	23
1.5 PROJECT CLOSE OUT	24
1.5.1 FINAL CLEANING	24
1.5.2 SITE RESTORATION	24
1.5.3 OPERATION AND MAINTENANCE MANUALS/DATA	24
1.5.4 SPARE PARTS AND MAINTENANCE MATERIALS	25
1.5.5 PREVENTATIVE MAINTENANCE SYSTEMS EQUIPMENT LISTS	25
1.5.6 WARRANTIES AND GUARANTEES	26
1.5.7 BENEFICIAL OCCUPANCY/FINAL INSPECTION	26
CHAPTER 2 HISTORIC PRESERVATION	27
2.1 HISTORIC PRESERVATION GENERAL	27
2.2 PRESERVATION GUIDELINES	27
2.3 CARE AND MAINTENANCE	27
2.4 ADAPTIVE USE OF BUILDINGS AND LANDSCAPES	28
2.5 ARCHAEOLOGICAL CONCERNS	28
CHAPTER 3 SITEWORK	29
3.1 SITEWORK GENERAL	29
3.1.1 INTRODUCTION	29
3.1.2 CONSTRUCTION SITE FENCING	29
3.2 SITE PREPARATION	29

3.2.1	SITE CLEARING AND BUILDING REMOVAL	29
3.2.2	DUST, MUD, AND DIRT CONTROL	29
3.2.3	PLANT PROTECTION	29
3.2.4	EARTHWORK	30
3.3	SITE DEVELOPMENT	30
3.3.1	PLANTING	30
3.3.2	PAVING AND CURBS	31
3.3.3	SIDEWALKS AND STAIRS	32
3.3.4	EXTERIOR SITE FURNISHINGS	32

CHAPTER 4 ENERGY AND UTILITIES **33**

4.1	OVERVIEW	33
4.1.1	UNDERGROUND UTILITY SEPARATION	33
4.1.2	UTILITY TRENCH CUTS IN ROADWAYS	33
4.1.3	UNDERGROUND UTILITY OFFSETS	33
4.2	STORM SYSTEMS	33
4.2.1	BUILDING AND ROOF DRAINAGE	33
4.2.2	STORM INLETS AND STRUCTURES	34
4.2.3	SITE STORM SYSTEMS	35
4.3	SANITARY SYSTEMS	35
4.3.1	SITE SANITARY SYSTEMS	35
4.3.2	SANITARY UTILITY STRUCTURES AND CLEANOUTS	35
4.4	EXTERIOR DOMESTIC AND FIRE SERVICE WATER PIPING	36
4.5	EXTERIOR CHILLED WATER PIPING	37
4.6	EXTERIOR DOMESTIC HOT WATER	37
4.7	PETROLEUM STORAGE TANKS	37
4.8	OIL INTERCEPTORS	38
4.9	NATURAL GAS	38
4.10	HEATING SYSTEMS	38
4.10.1	SOURCES	38
4.10.2	STEAM AND HOT WATER TUNNELS AND DISTRIBUTION SYSTEMS	39
4.11	FLUSHING REQUIREMENTS	41
4.11.1	CARBON STEEL PIPING	41
4.11.2	PLASTIC PIPING	42
4.12	POWER & LIGHT	42
4.12.1	SITE LIGHTING	42
4.12.2	SERVICE AND DISTRIBUTION	44
4.12.3	EV CHARGING STATIONS	47

CHAPTER 5 BUILDING ENVELOPE **48**

5.1	CONCRETE	48
5.1.1	ARCHITECTURAL CONCRETE	48
5.1.2	CAST IN PLACE CONCRETE	48
5.1.3	FIBER REINFORCED CONCRETE	48
5.1.4	POST TENSIONED STRUCTURAL CONCRETE	48

5.1.5	SLAB ON GRADE	49
5.2	SUPERSTRUCTURE	49
5.2.1	GEOTECHNICAL DESIGN AND EARTH PRESSURE LATERAL LOADS	49
5.2.2	STRUCTURAL COMPATIBILITY WITH EQUIPMENT: VIBRATION, MAGNETICS, ELECTRICAL SENSITIVITY	49
5.2.3	ADDITION OF LOADS TO EXISTING STRUCTURES	49
5.2.4	SPRAY FIREPROOFING DESIGN AND SPECIFICATION	49
5.3	EXTERIOR ENCLOSURE	50
5.3.1	EXTERIOR WALLS	50
5.3.2	EXTERIOR PAINT	51
5.3.3	EXTERIOR WINDOWS	51
5.3.4	EXTERIOR DOORS	51
5.4	ROOFING	52
5.4.1	GENERAL	52
5.4.2	LOW-SLOPE ROOFS AND ACCEPTABLE ROOFING SYSTEMS	52
5.4.3	STEEP-SLOPE ROOFS AND ACCEPTABLE ROOFING SYSTEMS	53
5.4.4	ROOFTOP-MOUNTED PHOTOVOLTAIC SYSTEMS	54
5.4.5	VEGETATED/TERRACE ROOFS AND ACCEPTABLE ROOFING SYSTEMS	54
5.4.6	UNACCEPTABLE ROOFING SYSTEMS	55
5.4.7	STEEL ROOF DECK	55
5.4.8	BLOCKING AND MISCELLANEOUS CARPENTRY	55
5.5	ROOF DRAINAGE, EQUIPMENT, AND ACCESSORIES	55
5.5.1	GENERAL	55
5.5.2	ATTACHED GUTTERS	56
5.5.3	BUILT-IN GUTTERS	56
5.5.4	DOWNSPOUTS	56
5.5.5	SNOW GUARDS	56
5.5.6	ROOFTOP SAFETY	57
5.5.7	ROOFTOP EQUIPMENT	57
5.5.8	ROOF HATCHES	57
5.5.9	SKYLIGHT STRUCTURES AND CLERESTORY WINDOWS	57
CHAPTER 6 INTERIORS		59
<hr/>		
6.1	DESIGN AND FINISH CRITERIA	59
6.2	PARTITIONS	59
6.2.1	GENERAL	59
6.2.2	FIRE RATED ASSEMBLIES AND FIRE STOPPING	59
6.2.3	OPEN OFFICE PARTITIONS	59
6.2.4	GLAZING	60
6.3	INTERIOR DOORS	60
6.3.1	GENERAL	60
6.3.2	MISCELLANEOUS DOOR HARDWARE	60
6.3.3	LOCKSETS AND ACCESS CONTROL	60
6.4	INTERIOR SPECIALTIES	60
6.4.1	FIRE EXTINGUISHERS	60
6.4.2	BUILDING SIGNAGE	61
6.4.3	TOILET AND BATH ACCESSORIES	61
6.4.4	TOILET PARTITIONS	61

6.4.5	WALL AND CORNER GUARDS	62
6.4.6	CHALKBOARDS	62
6.4.7	CUBICLE CURTAINS	62
6.4.8	DRINKING FOUNTAIN WITH BOTTLE FILL STATION	62
6.4.9	PUBLIC ACCESS AUTOMATED EXTERNAL DEFIBRILLATORS (AED)	62
6.5	INTERIOR FINISHES	62
6.5.1	WALL FINISHES	62
6.5.2	FLOOR FINISHES	63
6.5.3	CEILING FINISHES	64
 CHAPTER 7 BUILDING SERVICES		 65
<hr/>		
7.1	BUILDING SERVICES GENERAL	65
7.1.1	INTRODUCTION	65
7.1.2	REVENUE METERS FOR UTILITIES	66
7.1.3	SUBMETERING	66
7.1.4	AESTHETIC CONCERNS	67
7.1.5	SOUND PRESSURE LEVEL REQUIREMENTS	67
7.1.6	OPERATIONS AND MAINTENANCE MANUALS	67
7.1.7	COMMISSIONING	67
7.1.8	TRAINING AND DEMONSTRATION OF SYSTEMS	67
7.2	ELEVATORS	68
7.3	PLUMBING	68
7.3.1	DOMESTIC WATER	68
7.3.2	MATERIALS AND SYSTEMS	69
7.3.3	IDENTIFICATION	69
7.3.4	WATER DISTRIBUTION	69
7.3.5	STORM AND SANITARY WASTE SYSTEMS	70
7.3.6	PIPING SYSTEMS FOR GASES	70
7.3.7	EMERGENCY SHOWER AND EYEWASH EQUIPMENT	71
7.4	HEATING, VENTILATION, AND AIR CONDITIONING	71
7.4.1	DESIGN PARAMETERS	71
7.4.2	CHEMICAL CLEANING AND CHEMICAL WATER TREATMENT OF BOILERS AND HVAC SYSTEMS	73
7.4.3	MECHANICAL LOCATION AND EQUIPMENT	74
7.4.4	HEATING	76
7.4.5	VENTILATION	78
7.4.6	AIR CONDITIONING	82
7.4.7	COOLING COIL CONDENSATE	84
7.5	FIRE PROTECTION SYSTEMS	85
7.5.1	GENERAL	85
7.5.2	FIRE PROTECTION SPRINKLERS	85
7.5.3	FIRE PUMPS	87
7.5.4	PROTECTION DURING CONSTRUCTION	88
7.6	ELECTRICAL SYSTEMS	88
7.6.1	BUILDING ELECTRICAL SYSTEMS	88
7.6.2	SPECIAL SYSTEMS	95
7.6.3	ELECTRICAL TESTING	102
7.6.4	RECORD OR AS-BUILT DOCUMENTS	102

7.7	ELECTRONIC MONITORING AND CONTROLS	103
7.7.1	APPLICATION	103
7.7.2	BIDDING PROCEDURES	105
7.7.3	CONTRACT DOCUMENT GUIDELINES	105
CHAPTER 8 GREEN BUILDING STANDARDS		107
8.1	GENERAL REQUIREMENTS FOR ALL PROJECTS	107
8.1.1	ENERGY	107
8.1.2	INDOOR ENVIRONMENTAL QUALITY	112
8.1.3	MATERIALS AND WASTE MANAGEMENT	113
8.1.4	WATER	114
8.1.5	SITE & LANDSCAPE	115
8.1.6	LIFE CYCLE COST	115
8.2	CAPITAL PROJECTS – NEW CONSTRUCTION AND MAJOR RENOVATIONS	116
8.2.1	PROJECT INITIATION	116
8.2.2	DESIGN AND CONSTRUCTION	117
APPENDIX A – FIGURES		117
APPENDIX B – UTILITY METERING REQUIREMENTS		136
APPENDIX C – ELEVATORS		140
APPENDIX D – NOT USED		141
APPENDIX E – NOT USED		142
APPENDIX F – LOCKSETS & ACCESS CONTROL		143

Chapter 1 General Requirements

1.1 GENERAL INFORMATION

University of Virginia *University Design Guidelines* shall apply to all design projects unless specifically waived by the Chief Facilities Officer. Exceptions to the *Guidelines* shall be submitted by the Project Manager to the Chief Facilities Officer through the University Building Official (OUBO) with a “Determinations and Finding Report.”

1.1.1 DEFINITIONS/TERMS

Grounds: Comprised of Central Grounds, North Grounds, and West Grounds as illustrated in Appendix A Figure 1.

Historic Grounds: Area bounded by Jefferson Park Avenue, McCormick Road, University Avenue and Hospital Drive (up to and including facades of Cobb Hall, McKim Hall, Barringer Wing and Old Medical School buildings along Hospital Drive), as illustrated in Appendix A Figure 2. Portions of Rugby Road are also designated as a historic district.

The Academical Village: Original Jefferson-designed buildings and grounds, including the land bounded by McCormick Road, University Avenue and Hospital Drive; also including the South Lawn in front of Cabell Hall, as illustrated in Appendix A Figure 3.

Central Grounds: The area bounded by Emmet Street, University Avenue, Hospital Drive and Jefferson Park Avenue is the Historic Grounds and the Academic Village, as illustrated in Appendix A Figure 4.

University of Virginia Health System (UVA Health) Area: The School of Medicine, School of Nursing, Health Sciences Library and Medical Center are components of the Jefferson Park Avenue precinct bounded by Hospital Drive, University Avenue, Jefferson Park Avenue, the CSX Railroad, the Norfolk Southern Railroad and Brandon Avenue. Additionally, UVA Health includes the Orthopedic Center on Ivy Road, buildings in the Fontaine Research Park and other off-site clinical facilities.

Architect/Engineer (A/E): The Architect or Engineer of record who contracts with the University as the prime design professional to provide architectural or engineering services for a project. The term includes any associates or consultants employed by the A/E of record in the provision of project design services.

Project Manager (PM): The University’s designated representative for the project. This term is synonymous with “University of Virginia Project Manager” as defined in the most current version of Higher Education Capital Outlay Manual (HECOM).

1.1.2 DOCUMENTS

Documents shall conform to the CADD version currently in use by Facilities Management and confirm the mode of transmission prior to project initiation. Specific drawing requirements shall be in accordance with the most current version of HECOM.

Contract bid documents are to be dated with the actual date of final submission incorporating the review comments by the Office of the University Building Official and other applicable University

reviews. All project specifications shall be provided in PDF format (preferred) or the most current version of Microsoft Word format.

Facilities Management's base map is established on a set control datum. This control datum shall be used for all electronic mediums that pertain to mapping, civil and site work. Mapping shall be in accordance with National Map Accuracy Standards, based on Virginia State Plane Coordinate System, South Zone and North American Datum 1983 (NAD83). Vertical control is based on the North American Vertical Datum 1988 (NAVD88). NAVD88 Control Monuments have been established in various locations on the University Grounds using this datum. All construction or survey work shall be performed based on the most recent established control.

1.1.3 LIFE SAFETY DRAWING STANDARDS FOR ALL PROJECTS

Accurate life safety drawings shall be provided to Geospatial Engineering Services (GES) for all projects, regardless of occupancy or project size, both during CD submittal and as corrected as-builts prior to project closeout. Floor plan drawings for all disciplines shall follow UVA Life Safety CAD Requirements, linked on the OUBO website (<https://oubo.virginia.edu/udg.html>). GES maintains up to date life safety drawings for all University Hospital projects to facilitate accreditation; Project Managers may request up to date info from GES.

Life safety drawings shall contain the following minimum information:

- Legend clearly identifying life safety features
- Areas of the building that are fully sprinklered
- All use groups and occupant loads
- Location of exits from each floor, exit access and common path of travel distances, dead end length, and diagonal separation of exits necessary to show code compliance
- Locations of all hazardous storage areas
- Control area (and/or laboratory unit) boundaries, size, and # floors above/below grade
- Locations of all rated assemblies, identifying the type and hour rating required
- Locations of all smoke barriers, identifying the hour rating required
- Identification of all smoke compartments (follow existing labeling system for new compartments in existing UVA Health buildings)
- Suite boundaries, size of the suites, and identification of patient sleeping, patient non-sleeping, and non-patient suites
- Locations of chutes and shafts

1.2 CODES, UVA REVIEWS, PERMITS

1.2.1 GENERAL REQUIREMENTS

1.2.1.1 VIRGINIA UNIFORM STATEWIDE BUILDING CODE

The Building Code for all University projects on Commonwealth property is the current edition of the Virginia Uniform Statewide Building Code (VUSBC) with supplemental requirements, clarifications and modifications as indicated in this Manual. Refer to section *1.2.1.3 Accessibility* for accessibility standards for state-owned facilities and associated clarifications. The provisions of the VUSBC are based on nationally recognized model building codes and fire codes published by the International Code Council, Inc. These model codes are adopted by reference into the VUSBC. The VUSBC is divided into 3 stand-alone parts:

Part I - The Virginia Construction Code

Regulations specific to the construction of new buildings and additions

Part II – The Virginia Existing Building Code

Regulations specific to the rehabilitation of existing buildings, including renovations and change of occupancy

Part III – The Virginia Maintenance Code

(Not applicable to UVA construction and renovation projects)

1.2.1.2 OTHER FEDERAL, STATE, AND LOCAL REGULATIONS

Certain projects may be required to comply with other federal or state regulations. Those requirements may take precedence, equal, or exceed the construction, health, safety, and welfare standards regulated by VUSBC and are approved after review by OUBO. These include:

Title II, Americans with Disabilities Act of 1990

Virginia Statewide Fire Prevention Code (SFPC)

Virginia Industrialized Building Safety Regulations (IBSR)

Virginia Manufactured Home Safety Regulations (MHSR)

Virginia Amusement Device Regulations (VADR)

Virginia Public Building Safety Regulations

Virginia Fire Safety Regulations

Virginia Department of Environmental Quality (DEQ) Regulations

Virginia Department of Health Regulations

Virginia Occupational Health and Safety (VOSH) and OSHA Federal Register

Section 504 of the Rehabilitation Act of 1973 (HUD)

Fair Housing Act Accessibility Guidelines (HUD)

Facilities Guidelines Institute (FGI) for the Design and Construction of Healthcare Facilities

City of Charlottesville

Albemarle County

Local Railroads including CSX, Norfolk Southern, and the Buckingham Branch

1.2.1.3 ACCESSIBILITY

Virginia Construction Code Chapter 11 is the scoping document for accessibility. ICC A117.1, as referenced in the VCC, outlines the technical requirements for accessibility. Accessible facilities must be provided at completion of construction. Adaptable facilities do not meet the requirements for accessibility unless demonstrated to OUBO to be readily implemented on demand.

The following apply to all University projects:

1. Automated door operators are required at the following locations:
 - a. At the exterior and interior of all public entrance doors to a building. At entry vestibules, locate operators in the vestibule to open both exterior and interior doors.
 - b. At both sides of all multi-user public restroom doors on the main entry floor(s) of a building, and at least one accessible single user restroom. Not required at doorless

restrooms.

- c. Additional door operators, at large classrooms or other locations, shall be installed per consultation with the Barrier Free Access Committee.
2. At multi-user restrooms, design the entry to eliminate sight lines to any users in the room. Doorless entry with appropriate sound attenuation is preferred at multi-user restrooms.
3. Accessible installations should not look substantially different than standard installations. Restroom lavatories, lab workbenches and breakroom counters shall be of a uniform code-compliant design. This requirement does not apply to accessible toilet stalls or urinal mounting height.
4. Teaching and research laboratories and associated support spaces shall have a minimum 5% code-compliant work stations for each type of process (fume hoods, work benches, sinks, etc).
5. All passenger elevators shall be accessible.
6. All exterior and interior stairways shall be accessible.
7. Platform lifts are prohibited unless a D&F including approval of the Barrier-Free Access Committee is submitted to OUBO for installation in a renovation-only project.
8. Carpet is prohibited on interior sloped floors. Where no handrail is required by VUSBC at an interior sloped floor, a contrasting floor finish (change of material, color or texture) is required.
9. UVA prefers installation of Hearing Loop (induction loop) technology where an assistive listening system is required by code. Hearing loop installations shall conform to guidance linked on the OUBO website (<https://oubo.virginia.edu/udg.html>).
10. Provide wheelchair accessible toilet compartments at a minimum depth of 64 inches for wall-hung water closets or 67 inches for floor-mounted water closets per ICC A117.1 604.9.5.1 Exception 1.

1.2.1.4 LIFE SAFETY CODE

The requirements of the Life Safety Code, NFPA 101, apply only to the University Hospital and clinical facilities accredited by the Joint Commission on Accreditation of Healthcare Organizations (Joint Commission) and accepting federal Medicare and Medicaid funds (see 41 CFR Chapter 4 for a full list of Health Care code requirements for CMS Medicaid). Contact HSPP for a list of buildings that are subject to 42 CFR Chapter 4. In case of conflict, the most stringent requirements apply. Should there be a conflict with VUSBC that critically affects accreditation by the Joint Commission this must be resolved with the University Building Official.

1.2.1.5 DEMOLITION

Demolition or renovation work, which occurs on the floor below or above the primary construction site, shall be shown sufficiently to convey the extent of work necessary to maintain or maximize functional occupancy of the effected space.

1.2.1.6 REACTIVATED PROJECTS

Prior to reactivating a project that has been inactive for a period during which the effective Code has changed, the University Building Official shall determine which Code applies. The Plans and Specifications shall be revised as necessary to comply.

1.2.1.7 MODIFICATIONS TO CODE REQUIREMENTS

If a modification to the VUSBC is thought to be necessary, the A/E shall request such modification in writing with the preliminary design submittal. The request shall clearly state the nature of the problem and the supporting rationale and justification for the modification. All requests to waive or grant a modification to the requirements of the VUSBC will be addressed to the University Building Official using a Determinations and Findings Report (D&F) for Code Modifications.

1.2.1.8 USE GROUP GUIDELINES

The following guidance shall be used for buildings and structures at the University:

1. Buildings for business training and vocational training shall be classified and designed for the Use Group corresponding to the training taught.
2. Academic buildings, which include classroom-type education functions (including associated professor/teacher office spaces) where large groups of students must change classes on a schedule must incorporate a 72" minimum corridor width at classrooms.
3. The occupant load for all classrooms, and for breakrooms 750 square feet or greater, shall be calculated using the "Assembly without fixed seats" 15 occupants/sf load factor in VUSBC Chapter 10.
4. Dormitories, Fraternity and Sorority Houses, and similar dwelling units with sleeping accommodations shall provide one of the following:
 - a. Written University policy that prohibits the use of the residences as lodging for persons/groups/occupants for periods less than 30 days; or
 - b. Design that complies with the most stringent requirements of both VUSBC Use Group R-1 (Hotels) and Group R-2 (Dormitory), exclusive of minimum required plumbing facilities, which are to be based on Use Group R-2.
5. Cabins, beach houses, lodges and similar dwelling units with sleeping accommodations rented to family groups:
 - a. Residences for rent less for than 30 days with a maximum occupant load of 16 shall comply with the requirements for Use Group R-3.
 - b. Residences for rent for less than 30 days with a maximum occupant load of greater than 16 shall comply with the requirements for Use Group R-1.

1.2.2 REVIEWS AND APPROVALS

Submit documents using the Drawing Review Transmittal found on the OUBO website (oubo.virginia.edu).

1.2.2.1 FIRE SAFETY

Fire Safety reviews will be conducted by the University Review Unit for all construction projects. The Office of the University Building Official (OUBO) shall submit Capital Project review comments and Working Drawings to the appropriate Regional State Fire Marshal's office for their use in inspection of these projects and record purposes.

By University policy, all renovation projects are required to provide fire and life safety improvements up to 10% of the construction cost or to the extent required by Code, whichever is greater.

Fire suppression, fire detection and fire alarm Shop Drawings shall be reviewed and approved prior to the work being installed. Where a complete fire protection system is designed and shown on the

Final Documents, the Drawings and/or Specifications shall state that deviations in materials, locations, configurations or sizes proposed by the contractor are subject to being reviewed under the provisions of Section 26 of the Contract General Conditions as a “substitution.”

When the fire suppression, fire detection and fire alarm systems are not complete on the Final Documents, then Shop Drawings or Submittal data shall first be reviewed and approved by the A/E. The reviewed documents, with any added notations by the A/E, shall be submitted to the University Building Official’s office for final review and approval.

1.2.2.2 GREEN BUILDING STANDARDS

The University of Virginia Green Building Standards in Chapter 8: Green Building Standards outline UVA’s minimum expectations for aligning University-wide sustainability goals with building design, construction, and maintenance. The Standards apply to all projects which require a building or project permit.

Where there is a conflict between the University Design Guidelines general text and the specifics noted in Chapter 8, the more restrictive requirement shall govern.

1.2.2.3 OTHER REQUIRED REVIEWS

The following departments may provide review comments in parallel with OUBO. A/E consultants shall provide written comment response to the Project Manager for distribution to OUBO, as well as relevant UVA teams, including:

1. Facilities Management, including Zone Managers, Fire & Life Safety, Elevator Shop, Landscape Services, Recycling Services, Custodial Services, Office for Sustainability, Building Automation System (BAS), Energy & Utilities, Technology and Innovation, and Occupational Health and Safety.
2. Facilities Management Health System Physical Plant
3. Office of Emergency Management
4. University Police Department
5. Office of Environmental Health and Safety
6. Environmental Resources
7. Office of Fire Safety

Documents for deferred submittal items shall be annotated to indicate the review and approval of the appropriate registered design professional before submittal to OUBO. Deferred submittal items shall not be installed until OUBO approval is received.

1.2.3 PERMITS

Construction on University (state-owned) property requires a building permit whether constructed by Virginia licensed contractors, Facilities Management personnel, or other allowed “self-service” University personnel. OUBOs Building Permits and Project Permits Policy, or a subsequent update, describes the procedures applicable to building permits and project permits (under the “Annual Permit” authorization). This directive further defines construction-related work that does not require a building or project permit. If there is a question as to applicability of a building permit or a project permit, consult with OUBO.

Building permits are to be submitted as follows. Under Virginia law, Contractors may not start construction without an approved building permit:

1. Download and complete the current HECO-17 building permit form, available on the OUBO website (oubo.virginia.edu), as an Excel format file.
2. Submit the building permit electronically to BuildingPermitRequest@virginia.edu for processing by OUBO.
3. Projects requiring Stormwater Management or Erosion and Sediment Control Plans must have such plans approved by the UVA Standards and Specifications Administrator prior to permit approval (Stormwateradmin@virginia.edu).
4. Projects in or affecting patient healthcare facilities require Infection Control Risk Assessment (ICRA) and Interim Life Safety Measures (ILSM) documentation to be submitted and approved by Health System Physical Plant (HSPP) prior to permit approval. The Project Manager is responsible to ensure HSPP has the ability to review the design documents.
5. Properties under the ownership of the University of Virginia Foundation or the University of Virginia Physicians Group (UPG) require building permits for construction from the City of Charlottesville, County of Albemarle, or other applicable Building Official in whose jurisdiction the property is located. Design documents for these properties may, however, be subject to review for University Design Guideline requirements and constructability by the OUBO if it is known at the time of construction that the building will be acquired as a University owned and operated building.
6. Construction projects at the Mountain Lake Biological Station are issued building permits by the Giles County Building Official. These projects are reviewed by the OUBO for compliance with the VUSBC and for constructability.

1.3 SITE PLANNING REQUIREMENTS

1.3.1 GENERAL REQUIREMENTS

Incorporate recommendations from approved area studies and other criteria developed by the Office of the Architect of the University (OAU) in site design. The University encourages the use of sustainable site practices such as permeable surfaces, native biodiverse plantings, vegetated roofs, and low impact stormwater management when possible. Design shall promote efficient and safe pedestrian, vehicular, and service access, with pedestrian safety taking priority. Provide for emergency access for fire, ambulance, police and service vehicles. Coordinate with sections 1.4.3 Security, Chapter 3 Sitework and Chapter 8 Green Building Standards.

No building silhouette in the Central Grounds area, UVA Health area, or readily visible on a line of sight with the Rotunda, shall rise higher than the visual spring line of the Rotunda dome (elevation 631.75 feet above sea level).

Executive Order 45 establishes mandatory standards for development of state-owned properties in Flood-Prone Areas, which include Special Flood Hazard Areas, Shaded X Zones, and Sea Level Rise Inundation Areas. Any variance to the standards must be approved by the University Building Official, after consultation with the State Coordinator for the National Flood Insurance Program.

1.3.1.1 PARKING

The Parking Policy for Capital Projects applies to all new buildings, additions, and capital renovations. Requirements for site parking shall be determined during project programming and not later than Preliminary Design, as coordinated through the Project Manager in consultation with OAU.

Accessible parking spaces shall be located closest to the nearest accessible entrance on an

accessible route no more than 250 feet from the entrance.

Parking configurations and aisle width shall meet or exceed minimum dimensions recommended by recognized parking design standards. Consideration shall be given to duration of parking/turnover rate in sizing of spaces and aisles and to the protection of columns and walls by use of wheel stops, bollards or guards. Minimum parking space dimensions shall be as follows:

Parking Decks, Lots and Garages Utilizing Self-Parking		
Vehicle type	Minimum Width	Minimum Length
Standard cars	8'-6"	18'-0"
Compact cars*	8'-0"	15'-0"
Accessible spaces**	See ICC A117.1 502	

*Compact car spaces may be incorporated/designated when restrictions by walls, columns, piers, or other restraints impede the use of standard size spaces.

** Locate Accessible spaces to minimize Accessible users' exposure to crossing traffic.

1.3.1.2 SERVICE AREA PLANNING

All projects shall comply with UVA's Waste Infrastructure Design Requirements, linked on the OUBO website (<https://oubo.virginia.edu/udg.html>). The Project Manager and A/E shall consult with other Facilities Management departments and the Fire Marshal regarding additional space requirements for transformer(s), generator(s), and fire lane(s), and will coordinate design approval of all departments.

1.3.1.3 SITE INVESTIGATIONS AND SURVEYS

The A/E shall not rely solely on University records which are not guaranteed to be wholly accurate. In coordination with the Project Manager, the A/E shall determine any additional site investigation, including of underground utilities or structures, warranted to reasonably prevent conflict or unforeseen project cost.

All project site surveys provided to the University shall include trees and planted shrub beds within the project boundaries. Surveys shall identify tree species, DBH, and canopy extent. Shrub bed shall indicate extent of shrubs.

1.3.2 STORMWATER MANAGEMENT / EROSION & SEDIMENT CONTROL

1.3.2.1 GENERAL REQUIREMENTS

All projects involving land-disturbing activity subject to Virginia Stormwater Management (SWM) and Erosion and Sediment and Control (E&SC) Laws and Regulations shall be bound by the DEQ-Approved UVA Standards and Specifications for SWM/E&SC. Additionally, they shall follow the guidelines of the Energy & Utilities Master Plan Stormwater section or appropriate watershed master plan for Meadow Creek or Moore's Creek. Consideration of stormwater requirements should be made early in the project planning and design process. When possible, coordinate with concurrent or future projects within the same sub-watershed to satisfy stormwater requirements

and limit impact on existing habitat.

The University will ensure that their projects are located, designed, and constructed to protect the water quality and living resources of local streams and rivers and the Chesapeake Bay. Projects are encouraged to manage their stormwater requirements on-site using low impact development (LID) techniques that attempt to reconnect stormwater to the natural hydrologic cycle. Vegetated stormwater management facilities should be designed as site amenities that benefit the University community by providing accessible and attractive landscapes, educational opportunities and effective habitat. Excess treatment capacity in an existing SWM facility to meet a project's stormwater management requirements may be used if all of the following conditions are met:

1. The SWM facility was designed under the same technical criteria as the proposed site or conversion calculations must be approved prior to site plan approval,
2. The SWM facility has adequate capacity for the project, and
3. A Stormwater D&F is approved.

1.3.2.2 EROSION AND SEDIMENT CONTROL PLANS

Disturbance of land exceeding 10,000 square feet in Albemarle County or 6,000 square feet in the City of Charlottesville requires submission of an E&SC plan and narrative to the UVA Standards and Specifications Administrator for approval at the Construction Documents stage of plan development. Preparation and submission of the plan and narrative shall follow the requirements of the latest version of UVA Standards and Specifications for SWM/E&SC and the Virginia E&SC Handbook. In addition, the project manager must notify UVA Standards and Specifications Administrator regarding the project's certified responsible land responsible disturber (RDL) as well as provide the target groundbreaking date two weeks prior to disturbance.

1.3.2.3 STORMWATER MANAGEMENT PLANS

Site-specific SWM plans shall be prepared for all projects involving a regulated land-disturbing activity exceeding 10,000 square feet in Albemarle County or 6,000 square feet in the City of Charlottesville. SWM plans are also required for:

1. Land-disturbing activity within a watershed of a regional water quality SWM facility; or
2. Projects that incorporate the use of stormwater Best Management Practice (BMP)

SWM Plans shall be submitted to UVA Standards and Specifications Administrator for approval with the E&SC plan, if required. The SWM plan is not a substitute for the E&SC plan.

Projects that will install bioretention should consult UVA's Preferred Planting List for Bioretention Facilities when developing the planting plan. This is not an exclusive list but includes plants that have succeeded in stormwater management facilities on Grounds. A copy of the list is linked on the OUBO website (<https://oubo.virginia.edu/udg.html>) or by requesting it from the Standards and Specifications Administrator (stormwateradmin@virginia.edu).

1.3.2.4 CONSTRUCTION GENERAL PERMITS

Projects resulting in land disturbance equal to or greater than one acre must be covered under a VSMP General Permit for Discharges of Stormwater from Construction Activities (VAR10). The project's general contractor should apply for coverage under this permit. Information can be found on DEQ's website. Preparation of a Stormwater Pollution Prevention Plan (SWPPP) is a requirement of the general permit. Permit coverage is not a substitute for the E&SC or SWM plans.

1.3.2.5 PLANS AND SPECIFICATIONS

Site-Specific SWM and E&SC Plans will follow the latest regulations and design standards and include the information requested in the UVA Standards and Specifications for SWM/E&SC.

Requirements shall be included in the specifications to assign to the general contractor (as part of the contract) the responsibility of E&SC and SWM at all sites (on or off the University's property) of borrowing, wasting, or stockpiling of soil products. A statement similar to the following shall be used:

"The contractor shall be responsible for satisfying any and all erosion and sediment control (ESC) and stormwater management (SWM) requirements for any land disturbing activities, including but not limited to, on-site or off-site borrow, on-site or off-site stockpiling or disposal of waste materials. Before undertaking any land disturbing activity for which the plans do not specifically address erosion control and stormwater management, the contractor shall contact the UVA Standards and Specifications Administrator to determine what E&SC and SWM measures are necessary. The contractor shall completely satisfy all requirements of the E&SC and SWM regulations before continuing with the concerned activity."

1.3.3 ENVIRONMENTAL IMPACT REPORTS [EIR]

Projects, which have a projected \$500,000 or greater budget and have exterior scope of work, shall consult the Environmental Resources Department. Consultation should be scheduled prior to the construction documents submission. With the construction document submission to the Office of the University Building Official, provide verification of whether or not an EIR is to be provided.

Review by the regulatory agencies requires 60 days and a subsequent approval letter from the Governor's Office is required prior to commencing work.

1.4 BUILDING PLANNING REQUIREMENTS

1.4.1 GENERAL REQUIREMENTS

1.4.1.1 FIRE DETECTION, SUPPRESSION AND SIGNALING SYSTEMS

All new construction must include fire detection and suppression systems. Projects within existing facilities must include fire detection and suppression systems, but the cost of added fire detection in existing facilities need not exceed 3% of the renovation project construction cost.

Academic buildings with classroom and associated office space where large groups of students change class on a regular schedule, and buildings housing research, testing and science laboratories, must include a fire protection signaling system.

1.4.1.2 FLOOR AND ROOF DESIGN LOADS

Where the live loads in storage, mechanical, or similar spaces have been designed to exceed 50 pounds per square foot, the live loads shall be posted in that part of each story in which they apply.

1.4.2 SPACE PLANNING

Contract documents and specifications should not include attic stock except when the UVA project team requests that attic stock for a particular item(s) and space is designed into the project for the storage of stock material.

Space planning of offices, conference rooms, classrooms and furnishings shall be determined in consultation with the Director for Institutional Space Management. In existing buildings, reconfiguration should be weighed against the impact on historic material and a cost/benefit analysis.

1.4.2.1 ROOM AND DOOR NUMBER ASSIGNMENT PROCEDURE

All rooms must have State Council of Higher Education (SCHEV) room numbers assigned by the Assistant Director for Space Management in the Geospatial Engineering Services department or, in UVA Health, by the Office of Facilities Planning and Capital Development. The A/E, through the Project Manager, shall provide CAD files or half-size copies of floor plans not later than at the Preliminary Design submission for the assignment for room number assignments. Assigned room numbers shall be incorporated in the Construction Document submission. Any room configuration changes subsequent to room number assignment must be resubmitted for revised numbering.

Door numbers shall relate to assigned room numbers. A single door shall be numbered to match the room, such as 1001, 1001A or J1001 (where assigned room numbers have a suffix or prefix). Multiple doors in a room shall be numbered in a logical sequence such as 1001A, 1001B, or 1001A-1, 1001A-2.

During the bid phase the A/E shall provide a final CAD plan to the appropriate Space Administrator (Academic or UVA Health). Only relevant CAD layers should be visible in the file – i.e., walls, windows, doors, interior ramps, stairs, elevators, shafts, toilets, partitions (low/half walls, retractable wall systems, modular partitioning), roof outline, assigned SCHEV room numbering, room name, and occupancy load.

Where room and door-numbering signage is provided by the contractor it shall be installed prior to final inspection for occupancy or substantial completion.

1.4.3 SECURITY

1.4.3.1 DESIGN FOR CRIME PREVENTION

Projects shall be submitted to the Department of Safety and Security to review campus safety, security, card access and security camera locations. The Project Manager should schedule this review concurrent with the completion of Schematic Design.

Particular concerns, include landscaping, building entrances, walkways, and parking areas, which shall be adequately lighted and free of areas hidden from view that could encourage criminal activity. Line of sight and accessibility for police personnel shall be given design consideration, including proposed or future surveillance cameras.

The design process shall evaluate the following Design Checklist for Crime Prevention:

1. Make it difficult for people to harm the building, its occupants, and contents.
2. Use barriers to keep service vehicles from having easy access to areas not intended for vehicular traffic.
3. Provide adequate lighting.
4. Ensure emergency telephones are readily available. (See 1.4.3.6 Emergency Telephones)
5. Prevent unauthorized access from inside and outside the building to roofs, attics, adjacent buildings, and utility tunnels.
6. Design landscaping to contribute to security.
7. Incorporate Crime Prevention through Environmental Design (CPTED) concepts.

Underground utility structures (tunnels) required to have fire and emergency ingress or egress shall be alarmed to send signals to the police or a manned security post, and to FM Systems Control Center, as well as to audible devices at the point of entry and elsewhere within the building or on the building exterior. These alarmed points of entry shall be keyed so that authorized personnel can interrupt and reactivate the alarm circuit when the opening is closed.

1.4.3.2 SECURITY ACCESS (CARD READER) SYSTEM

All new buildings, renovation projects exceeding \$5,000,000 in project cost, or existing buildings with a building code change of use, shall include a security access (card reader) system for all exterior doors, and for such interior doors as determined by the Building Committee. The security access system shall be installed and operational prior to the issuance of a Certificate of Use and Occupancy.

The A/E, through the Project Manager, shall determine the design and operational compatibility of the security access system in consultation with the Office of the Vice President for Business Operations (Academic buildings) or Clinical Engineering and Biomedical Communications (UVA Health buildings). The system shall be compatible with the University's existing door security system(s). Submittals shall include product data and shop drawings. The system and components must be fully coordinated and integrated with all other building finishes, systems, and components. The system shall be submitted to the Office of the University Building Official, and to the Office of Vice President for Business Operations (Academic buildings) or ID Services (UVA Health buildings) for review and approval.

See also 1.4.3.5 Electronic Access Controls.

1.4.3.3 SURVEILLANCE CAMERA SYSTEMS

For all new buildings, renovation projects exceeding \$5,000,000 in project cost, or existing buildings with a building code change of use, the Office of Safety and Security Systems and Technology shall consider applicability of exterior and interior cameras.

When exterior cameras are requested, the project shall provide infrastructure as follows:

1. Conduit from selected exterior locations to accessible points inside the building
2. Power accessible to selected camera locations
3. Backboards at selected utility room locations, with power, data connection and adequate spatial requirements to accommodate and support the installation of a University compatible security camera system
4. The required exterior security camera infrastructure shall be installed and operational prior to the issuance of a Certificate of Use and Occupancy.

The University Architect's Office shall advise on the appearance and location of exterior cameras, consistent with achieving intended functionality.

The Department of Police will generally provide monitoring of security camera systems, but this service may require projects to provide additional monitoring capacity at the Department's central monitoring facility.

1.4.3.4 LED EMERGENCY NOTIFICATION DISPLAYS

All new or renovated classrooms or places of assembly with 60 or more persons shall provide a University furnished, contractor installed LED Emergency Notification display and Power Over Ethernet network connection. For more information about the LED Emergency Notification Displays or other UVA Alert services, contact ITS Emergency Notification Systems at emergencynotification@virginia.edu.

Major renovations (10,000 square feet or \$1,000,000 construction) shall incorporate security access systems. Smaller renovation access will be determined on a case-by-case basis. The Project Manager shall consult with the Department of Safety and Security, and/or Hospital Security as appropriate, to ensure incorporation of Crime Prevention through Environmental Design (CPTED) concepts.

Power for security systems and devices is to be from an emergency circuit where available.

1.4.3.5 ELECTRONIC ACCESS CONTROLS

1.4.3.5.1 GENERAL

Exterior doors in new construction and major renovations (plus select interior doors as requested and approved) shall be equipped with electronic access controls connected to the University's one card system. Through standing contract with the CBORD Group, Inc., the University electronic access control uses CBORD's Squadron access control panels. Squadron panels communicate with the University's CBORD CSGold servers over the University network, granting real-time access based on privileges assigned through the one card system.

All electronic access controls in UVA Health facilities shall be coordinated with UVA Facilities Planning and Capital Development (FPCD).

1.4.3.5.2 PERIMETER CONTROLS

Effective design and implementation of any electronic access control system requires an understanding of the intended use and typical daily operation of the facility. In order to be effective, the entire building perimeter must be addressed to determine the most cost-effective combination and layering of access control, including:

1. Primary entrance (during & after hours use). Typically equipped with card reader to allow after hours entrance, door is electronically locked & unlocked by predetermined schedule. Free egress at all times. Components include:
 - a. card reader
 - b. electronic locking hardware
 - c. door position switch
 - d. request-to-exit detector
 - e. local alarm sounder
2. Secondary entrance (accessible during normal business hours only). No after-hours access, door is electronically locked & unlocked by predetermined schedule. Free egress at all times. Components include:
 - a. electronic locking hardware
 - b. door position switch
 - c. request-to-exit detector
 - d. local alarm sounder

3. "Exit Only" door. Exit doors cannot be locked. If egress control is required, a "Delayed Egress" function is allowed in some instances with approval by the University Building Official. All of the delayed egress requirements noted in the code must be included.

Components include:

- a. door position switch
- b. local alarm sounder
- c. request-to-exit detector (not installed if designed for emergency exit only)

When determining whether card reader, electronic locking/unlocking, or monitoring should be specified, it is important to evaluate occupancy and use patterns for the facility. Where possible, points of highest traffic shall be equipped with electronic hardware for daily locking/unlocking. Card readers shall be installed on well-lit, easily identifiable and visible entrances. Monitoring and local audible ("prop") alarms shall be configured for all entrances to discourage propping of doors after hours. Keys shall not be issued to these doors, eliminating problems and costs associated with lost/misplaced/stolen keys and associated rekeying expenses. Lost cards can be immediately deactivated and new credentials issued without impacting other facility users.

1.4.3.5.3 SELECTION OF ELECTRONIC DOOR HARDWARE

The A/E shall follow the guidelines below when specifying electronic door hardware:

1. Function shall be fail secure:
 - a. Hardware provides free mechanical egress
 - b. No connection required to building fire alarm system
Note: certain life safety or fire code provisions may dictate the use of fail-safe hardware and interconnection with the building fire alarm system for specific doors. These exceptions must be coordinated with the Project Manager and reviewed by the University's access control specialist.
2. Electric locks, electric strikes and electric trim shall be 24Vdc. Provide filtered & regulated 24Vdc to power electric strikes, locks, and trim.
3. Electric latch retraction devices (See Appendix F for approved equipment list):
 - a. Typically require a manufacturer-specific power supply high in-rush current dictates conductor size and maximum cable length to power supply.
 - i. Max cable length may dictate installation of power supply near door
 - ii. Where possible, mount power supply in access control closet
 - b. Power supply to be mounted in central access control closet, adjacent to Squadron controls, with 120V AC cord and plug connection.
 - c. Specify hardware which includes battery backup integral to power supply
4. Accessible doors with power operators shall be equipped with electric strike or electric latch retraction device and be interconnected with the electronic access controls.
5. If pulls are desired on both leaves of double doors, both leaves shall receive electronic hardware (i.e., both doors unlock/unlatch on card swipe).
 - a. If electric hardware is not desired on both leaves, the inactive leaf shall not be equipped with an exterior pull.
 - b. Double doors with a single active leaf and one inactive leaf must be configured to ensure positive automatic latching of the inactive leaf whenever the active leaf is closed and latched. Manual head/foot bolts are not permitted on doors with electronic access controls.
6. Magnetic locks are discouraged due to increased life safety concerns (connection to fire system, local physical bypass switch, etc.).

7. Delayed egress hardware shall not be specified where the security posture dictates a locking hardware.

1.4.3.5.4 SPECIALTY HARDWARE

In addition to standard electronic hardware, which can be activated/controlled via relay contact closure or application of power, specialty products: Schlage AD-300 networked wired locks and Schlage AD-400 networked wireless locks are integrated with and fully configurable through CSGold. These specialty hardware options require far less door & frame prep than standard hardwired installations and can in some instances significantly reduce installation costs.

1.4.3.5.5 INFRASTRUCTURE REQUIRED

The A/E shall provide infrastructure for access control projects to include the following:

1. A dedicated location for installation of access controls per the following requirements:
 - a. Provide a dedicated room/closet with:
 - i. Locking door with electronic hardware and card reader
 - ii. Minimum 32 SF available wall surface area
 - iii. Controlled temperature and humidity
 - iv. Minimum two each dedicated 120V, 20 amp quad receptacle on emergency circuit with generator backup (if available). Facilities with large numbers of controlled doors or extensive use of latch retraction devices may require additional circuits or outlets.
 - v. Network (data) drop per V1000RX or V1000EVO controller
 - vi. Open paths/sleeves to pull cable from controls to door locations
 - b. Controls shall be installed per schematics in Appendix F: Locksets & Access Control Guidelines and the following:
 - i. Squadron controls shall be installed per the latest edition of CBORD Squadron Access Control Installation Guide.
 - ii. All cable shall be neatly routed around Squadron modules through finger duct (see schematics in Appendix F: Locksets & Access Control Guidelines).
 - iii. Composite cable outer jacket shall be stripped the minimum amount necessary to create adequate slack for termination of individual cable elements. Outer jacket shall be labeled with door number / designation at both ends of cable.
 - iv. Squadron connectors (V100, V200, V300) shall be labeled with door number/designation via self-adhesive label applied to face of module.
 - v. Fuses in low voltage power supplies (Altronix) shall be labeled with door or module designation of the device powered.
 - vi. Power supplies serving electric latch retraction exit devices shall be labeled with door number / designation via self-adhesive label applied to the outer cover of the power supply.
 - vii. Outer jacket of cables feeding individual exit devices shall be labeled with door number/designation at both ends.
2. Open raceways (EMT or LFMC only) with pull string from accessible and dedicated 8"x 8" junction box to points of termination within the door and doorframe. Refer to Appendix F for sample details. These are representative sketches intended to convey preferred routes for cable and typical installation details for various components and local

conditions. In addition to these line drawings, the following points shall be verified during design and construction:

- a. AC power shall not be run in the same conduit or junction box as low voltage access control cable
- b. Conduit routed to doorframe shall have the minimum number of wide radius bends required to reach the desired location. In no instance shall bends exceed 180 degrees without an intermediate (and accessible) junction box or pull "L"
 - i. Minimum conduit size to accommodate composite cable is 1" C
 - ii. Minimum conduit size to accommodate up to three individual cables separated from the composite cable is ¾" C
 - iii. Minimum conduit size to accommodate one or two cables separated from the composite cable is ½" C
- c. Install pull strings from junction box to point of termination in all conduits
- d. Grouted frames shall be equipped with mortar boxes around electric hinges, electric power transfers, electric strikes, door contacts, etc.
- e. Use factory installed raceway within hollow metal frames
- f. Where accessibility operators are installed:
 - i. Accessibility push button must be hardwired to the accessibility operator
 - ii. Card reader shall be installed adjacent to accessibility pushbutton, and may share a common conduit run to the 8"x 8" junction box

1.4.3.5.6 CONTRACTOR-FURNISHED COMPONENTS

The contractor shall furnish the following components and services with respect to access control projects (See Appendix F for approved equipment list):

1. Card readers
2. Alarm horns/sounders
3. Request-to-exit devices (motion detectors)
4. Door position switches (door contacts), normally open
5. Modular DC power supplies serving:
 - a. Squadron controls
 - b. Request-to-exit devices (motion detectors)
 - c. Alarm horns/sounders
 - d. Electric strikes/locks
 - e. Note: power supplies for latch retraction hardware shall be provided by hardware supplier
6. Cable

1.4.3.6 EMERGENCY TELEPHONES

New buildings, new parking lots and major site work projects shall provide location(s) for emergency telephone(s) that are accessible, hands-free operated and located on or near lighted walkways providing visibility and comfort in their use. The Project Manager shall determine approved locations and type of installation in consultation with the University Safety and Security Committee.

Two types of emergency telephone styles are applicable. In all installations the telephone shall be University provided and installed on or in the assembly. Power for emergency telephones is to be an emergency circuit where available:

1. The type applicable to most locations is a Facilities Management fabricated and installed assembly as illustrated in Appendix A Figure 5; installation will include all necessary wiring, cabling, the telephone, and the light fixture.
2. For areas determined by the University Safety and Security Committee and large parking lots (more than 49 cars), the use of a pre-manufactured “tower” type emergency telephone assembly is appropriate. For each 99 parking spaces, an additional emergency telephone is required. The University Landscape Architect must approve “tower” type assemblies taller than 8’ for large parking lots where visibility over vans and similar taller vehicles is required.

Where tower-type emergency telephones are specified, the design shall be similar to GAI-Tronics Corporation Model 234 Stanchion and/or model ETP-MT/R by Talk-A-Phone Co. and shall be accessible. Color(s) shall be approved by the University Landscape Architect.

1.4.4 HAZARDS

1.4.4.1 ASBESTOS ABATEMENT

1.4.4.1.1 GENERAL ASBESTOS ABATEMENT DISCOVERY REQUIREMENTS

The National Emission Standards for Hazardous Air Pollutants (40 CFR Part 61) regulation requires that a facility be thoroughly inspected for the presence of asbestos prior to renovation or demolition operations, without regard to the date the facility was constructed or previously renovated. The University shall test for the presence of asbestos in building materials prior to submittal of the Preliminary Design in accordance with UVA policy on ACM Management through the Office of Environmental Health & Safety (OEHS). An asbestos survey/inspection report must be made available to the project A/E for information and use in preparing the project documents and cost estimate for asbestos abatement. The A/E is responsible to the University to coordinate the design with the asbestos abatement work in order to prevent conflicts, claims and work stoppages.

If building materials are found that contain asbestos (including materials containing 1% or less asbestos), the University’s licensed asbestos designer in concert with the A/E will prepare an Asbestos Abatement Specification. Based on the asbestos survey/inspection report and the Asbestos Abatement Specification, the construction documents shall indicate all locations where ACM have been found and/or where ACM are to be disturbed.

The demolition plan sheets and the architectural floor plan sheets for each floor shall have an *Asbestos Disclosure Statement* indicating one of the following:

1. “An asbestos inspection was performed and no asbestos-containing materials were found. The asbestos survey/inspection report is available to the Contractor(s) for demolition and construction.”
2. “An asbestos inspection was performed and asbestos-containing materials were found generally in the areas indicated. However, the Work in this Project is not intended to disturb the existing asbestos-containing materials. The asbestos survey/inspection report and the Asbestos Management Plan are available to the Contractor(s) for demolition and construction.”
3. “An asbestos inspection was performed and asbestos-containing materials were found generally in the areas indicated. The asbestos survey/inspection report is available to the Contractor(s). The asbestos-containing materials shall be removed prior to any other

Work being performed in these areas. The Asbestos Abatement Specification is included in the documents. OEHS will mark-up the Asbestos Management Plan to show the “As-Built” conditions at the conclusion of the Work.”

4. “An asbestos inspection was performed and asbestos-containing materials were found generally in the areas indicated. The asbestos survey/inspection report and the Asbestos Abatement Specification are available to the Contractor(s) for demolition and construction. Asbestos-containing materials shall not be disturbed in this Work except where specifically indicated and required for connections to utilities. Where such connections are required, the UVA PM and OEHS will determine approved procedures as specified. The asbestos-containing materials that are to remain and the new non asbestos-containing material shall be labeled accordingly. OEHS will mark-up the Asbestos Management Plan to show the “As-Built” conditions at the conclusion of the Work.”

In addition, the use of materials that contain asbestos shall be prohibited in any new construction or renovation work. See section 11 (e) of the General Conditions of the Contract for Capital Outlay Projects for asbestos-related work insurance requirements.

1.4.4.1.2 ASBESTOS REMOVAL

Asbestos removal requires a building permit. All ACM that may be disturbed as a result of the Work must be removed or properly repaired. The University has two contracting options for use in removal of asbestos:

1. A separate contract for removal of the asbestos prior to renovation, demolition or addition; or,
2. A contract where the abatement is an integral part of the renovation, addition or demolition project in which the general contractor is licensed as an asbestos contractor or hires a licensed asbestos abatement Subcontractor to perform the work.

1.4.4.1.3 REMOVAL AND REPLACEMENT OF SPRAYED-ON FIREPROOFING

The A/E, in consultation with the University, shall verify early in the design phase with the Office of the University Building Official the original purpose of any fireproofing material to be removed or replaced and what, if anything, must be done to restore the fire resistive characteristics. If sprayed-on ACM is to be replaced, the A/E shall submit copies of the proposed specifications for the intended replacement material and any bridging encapsulate for review. The bridging encapsulate must be correctly matched with the replacement material to ensure maximum bonding strength and to maintain the intended fire rating integrity of the assembly. See also 5.2.4 Spray Fireproofing Design and Specification.

1.4.4.1.4 ASBESTOS RELATED WORK INSURANCE REQUIREMENTS

See SECTION 11(e) of General Conditions of the Contract for Capital Outlay Projects requires the asbestos contractor or subcontractor, as the case may be, to name the A/E as an additional insured on the contractor’s liability insurance with asbestos coverage. Where the A/E for the renovation project prepares the asbestos project drawings, the requirement of SECTION 11(d) to name the A/E as an insured party is waived. Professional Liability/Errors and Omissions insurance, with asbestos coverage, in an amount not less than \$1M is required.

1.4.4.1.5 CONFLICT OF INTEREST POLICIES

All laboratories utilized for asbestos sampling analyses for project purposes shall have no direct

business or financial relationship with the contractors conducting asbestos abatement activities.

1.4.4.2 SPECIAL PROCEDURES FOR LEAD CONTAINING PAINT

In renovation and demolition projects OEHS shall conduct a survey for lead-containing paint, documenting all quantities and locations found. Where lead-containing paint is suspected or pre-determined, an estimated cost for any special procedures required shall be included in the cost estimate supporting the construction budget or budget request.

The construction documents for all renovation, demolition and addition projects shall indicate all locations where lead-containing paint is to be disturbed or to remain, and shall include a Lead-Containing Paint Disclosure Statement indicating one of the following:

1. "A lead-containing paint inspection was performed, and no lead-containing paint was found."
2. "A lead-containing paint inspection was performed, and lead-containing paint was found in indicated areas. However, the work in this project is not intended to disturb existing lead-containing paint."
3. "A lead-containing paint inspection was performed, and lead-containing paint was found in the areas indicated. The contractor shall be responsible for compliance with all VOSHA regulations regarding lead-containing paint protection for workers."

Following removal of lead-containing paint, additional TCLP tests in accordance with EPA guidelines shall be done on these materials to determine disposal requirements as hazardous waste or as ordinary construction debris. It is unlawful for materials identified as hazardous waste to be disposed of with ordinary construction debris.

1.4.4.3 CONFINED SPACE REQUIREMENTS

All structures shall be designed in an effort to minimize confined spaces where configuration, size or location hinders the activities of the employees who must enter and work in the space and the space is not designed for continuous occupancy (examples include underground vaults and tanks). Where newly created confined space is unavoidable, the following guidelines must be considered to reduce the hazards associated with the space:

1. Install a remote monitoring and inspection system and automated cleaning system to eliminate or minimize the need for entry.
2. Provide mechanical ventilation to avoid build-up of contaminants or combustible atmospheres.
3. Design adequate means of entry and exit to accommodate persons who may be required to wear personal protective equipment, a breathing apparatus, and protective clothing.
4. Design suitable illumination on emergency power (no timer switches) for safe entry, conducting work and exiting.
5. Eliminate fall hazards. Provide fixed ladders, guardrails, platforms and anchor points for personal fall arrest systems, and provide non-slip work surfaces (e.g., textured flooring).

1.4.4.4 HAZARDOUS WASTE STORAGE

In addition to code requirements (including rated enclosure, dedicated ventilation and floor containment system), the A/E must adhere to the following guidelines when designing a hazardous waste shipping, receiving and/or storage area:

1. Doors to the area must be equipped with locks to prevent unauthorized entry.
2. Waste containers must be adequately segregated and contained. Provide minimum 3' of aisle space between shelving and waste containers.
3. Radioactive material storage may require special locking arrangements. Contact Radiation Safety Officer for any additional requirements.

In addition to code-required equipment (including fire suppression, extinguishers, emergency shower and eyewash), a spill kit must be provided in hazardous waste storage areas.

1.4.4.5 FALL HAZARDS

Structures shall be designed to eliminate fall hazards for persons engaged in maintenance, repairs and related activity. Consideration should be given to fall protection systems in the following order:

1. Elimination of hazard by means of guard rails, fixed barriers or other design solutions that remove the fall hazard.
2. Protection by Fall Restraint.
3. Protection by Fall Arrest.

Where exposures to fall hazards are unavoidable, incorporate the following into building design:

1. Anchorages to which personal fall arrest equipment is attached shall be capable of supporting at least 5,000 lbs (22.2 kN) per employee attached as required by the Occupational Health and Safety Administration (OSHA Standard 1926.502).
2. Install 39" high guardrails and toe boards where people are exposed to falls greater than 4-feet. Standard railings with standard toe boards shall be installed on all exposed sides except at the entrance to the opening. The railings and toe boards shall be constructed in accordance with the ANSI standard A1264.1-1995.

1.4.4.6 SOURCES OF NOXIOUS OR TOXIC FUMES

Projects shall be designed to prevent noxious/toxic fumes from entering occupied spaces, recognizing some buildings have more stringent needs (such as where large numbers of persons gather or in medical research buildings). All new buildings and those projects involving major renovations and upgrading of heating, ventilation, and air conditioning systems shall incorporate the following:

1. An EHS assessment shall be made during the design process to review the proposed construction. The assessment shall determine the impact construction activities may have on the air quality. The project manager shall contact EHS during the final design review period, to determine the need & scope of an indoor air quality (IAQ) plan.
2. Site and building design shall include consideration of outside air intakes for heating, ventilation and air conditioning related to sources of noxious or toxic fumes. The A/E and Project Manager are required to understand existing conditions and/or prevailing winds and account for these factors in the project design.

1.4.5 REQUIREMENTS FOR SPECIFIC USES

1.4.5.1 CUSTODIAL ROOMS

Provide one custodial room for each 15,000 to 18,000 gross square feet, with a minimum of one room per floor. Locate closets adjacent to restrooms and elevators. Valves, electric panels and

equipment, thermostats, and terminal boards for telephone, data or other low voltage equipment shall not be placed in custodial rooms. Within each custodial room, provide a combination emergency eyewash & drench hose unit [not an emergency shower] with an ASSE 1071 tempering valve set to 85°F.

Provide a central custodial room in each building on a level accessible from a service or loading dock entrance, containing a minimum area of 130 square feet (20 square feet in trailers), to accommodate the following:

1. Floor space for one wheeled cart and one floor machine
2. 18 linear feet of heavy duty metal shelving 24" deep with 18" vertical separation between shelves, not exceeding 7'-2" from floor to top shelf
3. 3' x 3' floor sink with drain and three mop holders, with impermeable surface 2' minimum above the sink on any adjacent wall.
4. Provide a combination emergency eyewash & drench hose unit [not an emergency shower] with an ASSE 1071 tempering valve set to 85°F.
5. Broom hanger strip to accommodate minimum of three brooms
6. Space to accommodate two stepladders
7. Space for small desk with data/telephone outlet
8. Two GFCI type duplex electrical outlets centered 18" above the floor in accessible locations (one adjacent to corridor door)
9. Motion detector switch for overhead light fixture
10. Water resistant epoxy flooring (turned up 4") with a floor drain. Floor shall slope 1/4" per foot floor to the drain throughout the room.
11. Four metal hooks mounted on inside of corridor door. If door is fire-rated, hooks may be located adjacent to the door
12. In UVA Health facilities, all EVS closets shall have sealed/epoxy floors and be provided with a waterbug to alarm in the event of a leak in the room.

1.4.5.2 INFORMATION TECHNOLOGY SERVICES (ITS)

The Project Manager shall coordinate ITS requirements with Information Technology and Communications during Programming and Schematic Design. ITS equipment rooms shall be dedicated for ITS use only (telephone, data and entertainment video services). These rooms shall not be used to support any other building utility.

The University IT Building and Cabling Standard is applicable to newly installed systems. All systems shall meet this standard unless specific exceptions are obtained directly from the Office of UVA IT Enterprise Infrastructure.

Telecommunications room/closets shall include the following:

1. Minimum size 6' x 8' (serving up to 100 outlets). Room size must accommodate projected number of outlets served including not less than 33% growth.
2. Minimum height 9'
3. No suspended ceiling unless required by building code
4. A lockable 3' x 6'-8" out-swinging door. If in-swinging door is required by building code, the room size may need to be increased.
5. 50 foot-candles illumination level at 3' above floor, light fixtures mounted 8'-6" minimum clear above floor (no wall mounted light fixtures)

6. IT rooms shall be cooled by a dedicated piece of HVAC equipment, with the cooling source preferably from the central chilled water system. No water piping shall be run over IT equipment. Verify chilled water is available year round. An ambient temperature of less than eighty degrees (typical heat load < 6,000 watts), with 30-75% relative humidity, and slight positive pressure must be maintained at all times. Cold supply air shall be directed down to the “cold” side of equipment intakes, and the return duct termination shall be high in the space above the “hot” discharge of the equipment. HVAC requirements shall be maintained 24/7 the entire year.
7. Fire-treated ¾” plywood installed from floor to 8’ above floor on minimum 3 walls of room
8. Stacked vertically where possible and interconnected by four 4” bushed sleeve floor penetrations extending 1” above the floor
9. Interconnected horizontally at minimum of every three floors with a cable tray above suspended ceiling (or conduit where ceiling is not accessible), with a run distance not exceeding 90 meters.
10. Within 90 meters cable run distance of the most remote site. Multiple closets are required if this distance cannot be achieved with one closet.
11. In UVA Health facilities, all EVS closets shall have sealed/epoxy floors and be provided with a waterbug to alarm in the event of a leak in the room.

Cable tray, when provided, shall be a minimum of 12” x 4” deep. See 7.6.3.1 Telecommunications, for additional technical requirements, such as electrical power outlets, building entrance termination, grounding, cable tray, conduit, and outlets.

1.4.5.3 AUDIO-VISUAL TECHNOLOGIES

All projects requiring audio-visual systems for any spaces must coordinate with ITS-Classroom Support during design development.

1.4.5.4 LACTATION ROOM DESIGN

Incorporate all the following requirements in new buildings and major renovations. In a small project or where a room is temporarily reassigned for a Lactation Room, incorporate the following requirements to the extent feasible. Where a single room is intended for both mental health use and lactation use (typically labelled a ‘Wellness Room’), access control must be monitored to ensure the room is reasonably available at multiple times throughout the day for lactation:

1. Size: Minimum 50 square feet
2. Location: Must be on an accessible route. May not be located within, or accessed from, a toilet room.
3. Access Control: Provide either a user-operated deadbolt which displays ‘occupied’, or card reader control. If card reader, ensure users know the process to request access.
4. Acoustics: Extend wall framing to structure above. Install sound attenuation.
5. Finishes: Floor finish may not be carpet.
6. HVAC: Install thermostat in room for user control.
7. Plumbing: Provide an accessible sink and gooseneck faucet to facilitate bottle washing.
8. Electrical: Provide a dedicated outlet to power refrigerator, and additional outlets to power breast pump, task light, and laptop or charger.
9. Equipment: Provide Energy Star certified compact refrigerator.
10. Fit-Out: Provide a work surface (table or small desk), task light, adjustable lounge

chair with arms (preferably recliner), trash bin, paper towel dispenser, coat hook, mirror, soap dispenser and hand sanitizer.

1.4.5.5 WASTE INFRASTRUCTURE

All projects shall comply with UVA's Waste Infrastructure Design Requirements, linked on the OUBO website (<https://oubo.virginia.edu/udg.html>).

1.4.5.6 VIVARIUMS

Vivarium and other research or clinically related animal holding facilities are required to meet architectural, mechanical, electrical and plumbing standards established by the current edition of the Guide for the Care and Use of Laboratory Animals, Institute of Laboratory Animal Resources, Commission on Life Sciences, National Research Council and National Academy Press.

1.4.5.7 LASER LABS (CLASS 4 AND 3B)

All new and renovated laboratories housing research that employs Class 4 lasers shall be designed with a laser-controlled area (LCA). All new and renovated laboratories housing research that employs Class 3B lasers should be designed with a laser-controlled area (LCA). The designs will be submitted to, reviewed and approved by the University Laser Safety Officer. In addition to all building code and accessibility requirements, minimum design requirements for the LCA can be found on the UVA Environmental Health & Safety website.

1.4.5.8 MAKER LAB SPACES

Spaces with equipment for making and assembling that produce odors, vapors, volatiles, fumes, dust, particulates or smoke shall have adequate exhaust to remove all contaminants. Some maker lab equipment can trigger air permitting requirements, regardless of whether or not the equipment exhausts to the exterior of the building. Consult with UVA Environmental Resources during the design process to assess if an air permit is required.

Equipment layout, especially for larger machines, may determine specialized electrical requirements beyond standard wall receptacles. Consideration should be given to supplying ceiling outlets with retractable cord reels.

Maker Labs and similar spaces shall have controlled access. An emergency eyewash shall be provided. Consult the UVA Environmental Health & Safety website on Shop and Studio Safety for additional requirements.

1.4.5.9 TWO-WAY COMMUNICATION SYSTEM

Where a two-way communication system is code-required, the Project Manager shall coordinate the type of device to be installed with ITS. Devices shall provide a push button (no handset). Required signage shall be per the UVA Signage & Wayfinding Guidelines, linked on the OUBO website (<https://oubo.virginia.edu/udg.html>). Devices shall provide communication as follows:

1. First to the building Fire Command Panel (or to the building Fire Command Center in a high-rise).
2. Timed, automatic dial-out to the Page Operator for Medical Center buildings on Grounds.
3. Timed, automatic dial-out to local 911 Emergency Communications Center for all other buildings.

1.4.6 BUILDING DEDICATION PLAQUES

Building dedicatory plaques are included as part of all new building projects. See the Commemorative Plaques on the Office of the Architect for the University of Virginia website for design guidelines. The University shall procure and install the plaque.

Unless approved by the President of the University, building identification shall not be engraved onto or included in the fabric of the building, such as in a cornerstone, engraved stone or surface mounted lettering.

1.5 PROJECT CLOSE OUT

1.5.1 FINAL CLEANING

Final cleaning shall include, but not be limited to, cleaning in compliance with manufacturer's instructions, interior and exterior glass, mirrors, floors, other interior finishes, mechanical and electrical equipment, removal of stains and foreign substances exposed to view, vacuuming of clean soft surfaces, polishing of transparent or glossy surfaces, and other such requirements to leave the project area in finished condition. Final cleaning shall be inspected by Building Services with the Construction Administrative Manager or Project Manager.

Contractor shall be responsible for resilient floor stripping and finishes. A Green Seal floor finish shall be required. The contractor must consult with Building Services Management Team prior to the start of project floor care step.

1.5.2 SITE RESTORATION

The contractor shall restore all existing gravel areas, paved areas, walks, drives, storm drains, etc. to their original condition.

The contractor shall restore all grassed or turf areas disturbed by construction activities, including areas used for access, staging, parking and storage in accordance with established requirements in the construction documents and found acceptable to the University's Landscape Superintendent. General instructions to restore grassed or turf areas to original condition are not acceptable. Copies of the University's Turf Restoration Specifications are available through the Project Manager.

When the Project Manager directs that finish landscaping is to be accomplished by separate contract, the construction documents shall include specific requirements for leaving the site ready for landscaping.

1.5.3 OPERATION AND MAINTENANCE MANUALS/DATA

The contractor shall submit all operations and maintenance manuals to the A/E for review and approval. The A/E approved manuals shall be submitted to the Construction Administration Manager prior to final demonstration of the equipment.

For new buildings or major renovations, the contractor shall provide a cabinet for maintenance manuals in a visible, secure location sized to contain a complete set of operations and maintenance manuals.

Provide one complete set of manuals in both digital and printed format to be delivered to the A/E for submission to Facilities Management through the Construction Administration Manager. Each set of manuals is to be in individually bound volumes based upon CSI standard specification headings.

Manual binders shall accommodate 8.5"x11" pages, be stiff-backed, plastic or canvas covered three ring type loose-leaf binders with the project name and division permanently lettered on the spine. When larger pages are necessary, they shall be neatly folded to 8.5"x11" as pullouts or foldouts.

Each copy of the manuals shall include:

1. Names, addresses and trades of all applicable subcontractors, manufacturers and equipment
2. Complete maintenance instructions from the manufacturer's local representative for each item of operable equipment, as well as the name, address and telephone number of the installing subcontractor
3. Catalog data on all items submitted and other pertinent data such as mortar colors, brick selected, and colors selected for all finished materials and fabrics
4. Catalog data on all furnished plumbing fixtures, valves, water heaters, heating equipment, light fixtures and similar equipment and systems. Manufacturer's promotional literature is not acceptable
5. Manufacturer's name, model number, service manual, spare parts list and descriptive literature for all components used
6. Preventive maintenance instructions and schedules for all major equipment
7. List of most frequently encountered breakdowns and repairs/trouble shooting manual(s)
8. Instructions for starting and operating the actual system as installed
9. Detailed one-line, color-coded wiring diagrams
10. Schedules on contractor's As-Built drawings and subsequent A/E's Record Drawings shall indicate the actual make, model and size for each piece of equipment used.
11. Sections for major equipment to be included in the Preventive Maintenance Systems Equipment Lists (See 1.5.5 Preventative Maintenance Systems Equipment Lists) should be identified by unique ID number to be provided by Facilities Management CMMS staff.
12. Floor plans identifying all lighting control device locations.
13. An air handler level HVAC zone mapping floor plan that indicates which rooms are served by each air handler.

1.5.4 SPARE PARTS AND MAINTENANCE MATERIALS

Spare parts and maintenance materials shall be turned over to the Construction Administration Manager at final inspection. Keys, other than those provided by Facilities Management, shall be delivered to the Construction Administration Manager at the final inspection. Construction documents shall state these requirements. See Appendix F: Locksets and Access Control.

1.5.5 PREVENTATIVE MAINTENANCE SYSTEMS EQUIPMENT LISTS

For all projects installing new or replacement equipment requiring routine/preventive maintenance by Facilities Management (FM), equipment should be clearly identified in equipment schedules within the project documents in the Construction Documents. Schedules should address components of systems including but not limited to elevators, fire protection and detection systems, electrical, exit signs, emergency lighting, generators, HVAC, refrigeration, roofing, fall-arrest systems, water and sewer, heat distribution, plumbing, backflow preventers and storm water management practices. In UVA Health facilities additional equipment shall be identified including fire doors, fire system components, special pressure rooms/regulated spaces, and ice machines. All asset groups included on the second tab of the Asset Turnover Form should be included in equipment lists.

Equipment schedules shall include unique asset ID numbers that are generated from UVA's Integrated Workplace Management System (IWMS). The numbers will be provided to the UVA project manager

by the UVA preventative maintenance manager. Engineers should plan to provide equipment lists for asset ID assignment to the UVA project manager early, so as not to delay Construction Document submittal. In addition, projects demolishing or replacing existing equipment currently tracked in UVA's IWMS must clearly identify such equipment and its asset ID number(s). The UVA preventative maintenance manager may assist the project manager with identifying existing asset numbers for equipment to be demolished.

During construction, the contractor shall complete a data inventory spreadsheet (Asset Turnover Form) for all installed equipment and building components individually listed on the equipment schedule as well as any equipment added to the project scope following permit issuance. Prior to turnover to UVA, the contracting team will submit a draft of the completed data inventory (Asset Turnover Form) to the UVA preventive maintenance manager for review. Upon successful review, the preventive maintenance manager will upload the newly installed assets into UVA's IWMS and provide barcode stickers with the unique asset IDs for each piece of equipment identified to be added to the IWMS. The Project Team will be responsible for applying barcode stickers on the installed equipment and provide all special tools, training and test equipment required for maintenance.

1.5.6 WARRANTIES AND GUARANTEES

All warranties and guarantees shall be drawn in the name of the Commonwealth of Virginia and the Rector and Board of Visitors of the University of Virginia and shall be delivered in print and digital format by the A/E to the Construction Administration Manager.

The contractor shall submit PDF files of warranties and guarantees and one commercial quality, hardback binder sized to accommodate 8.5 by 11-inch pages, with a table of contents and one copy of each warranty or guarantee. Marked tabs shall separate warranties and guarantees in sections following the order of the specifications.

Training shall be provided to Building Services staff if new or unusual floor finishes are installed. Specification manuals for floor care shall be provided to Building Services Superintendent and Associate Director.

1.5.7 BENEFICIAL OCCUPANCY/FINAL INSPECTION

Prior to beneficial occupancy of a project, the building(s) must be inspected and accepted, on both interior and exterior, by the Project Manager, Construction Administration Manager, A/E and the Office of the University Building Official. Exterior lighting shall be operational and exposed earth adjacent to buildings and walkways serving buildings shall be graded and protected to prevent erosion. Trash receptacle pads shall be in place and accessible to collection equipment. Any continuing construction activity on the balance of the project, including equipment and vehicle access, shall be identified on a list.

The contractor is responsible for the final inspection held in the presence of the Project Manager, the Construction Administration Manager and the A/E. The responsible Facilities Operations or UVA Health System Physical Plant (HSPP) Zone Maintenance Supervisor shall be a participant.

Inspection of Capital Outlay projects by both the Office of the University Building Official and a representative of the State Fire Marshal is required. The Project Manager or Construction Administration Manager will coordinate this inspection(s) as determined with the A/E.

Chapter 2 Historic Preservation

2.1 HISTORIC PRESERVATION GENERAL

The Historic Grounds consists of buildings within the Central Grounds Area, including Thomas Jefferson's Academical Village, that are considered historic landmarks. In addition, many other buildings within the University are classified as landmarks or components of designated historic districts. See the Office of the Architect for the University website for the Historic Preservation Framework Plan, Historic Structures Report, and other preservation-related information. See Appendix A Figures for diagrams and the OUBO website (<https://oubo.virginia.edu/udg.html>) for helpful links.

2.2 PRESERVATION GUIDELINES

The management and conservation of historic resources is a priority requiring cooperation between departments and disciplines throughout all phases of the work. Observe the following guidelines on all projects related to historic resources at the University:

1. Historically significant structures and landscapes must be recognized and acknowledged to promote appreciation, understanding and respect for them.
2. Pursue an active program of studying and recording the University's historic resources.
3. Historic Structure Reports, Building Assessment Studies and Cultural Landscape Reports should be performed as needed on buildings and landscapes as a part of project planning.
4. An active public outreach program involving presentations by preservation staff should be developed to communicate the findings and goals of the Preservation Framework Plan to Facilities Management, the schools and departments within the University, and to the broader Charlottesville community.
5. The permanent collection of records and information chronicling the development and evolution of the University's historic resources should be maintained and enhanced.
6. An active program for listing resources on the National Register of Historic Places should be pursued.
7. Archaeology must be incorporated into projects involving ground disturbances.
8. A design review process involving preservation specialists on the University staff should be implemented to evaluate proposed repairs on, alterations to and improvements of historic resources. Revisions to projects may be necessary to avoid altering or damaging the integrity of a building or landscape.

2.3 CARE AND MAINTENANCE

In the on-going process of maintenance, the most appropriate action is the one that achieves the desired goal with the least negative effect on the historic resource. Historic resources are the product of practices and materials not commonly employed in contemporary construction; therefore, the use of traditional methods, techniques and skills for conservation buildings should be embraced by the University to ensure appropriate repair and maintenance of historic buildings.

1. Active conservation of historic buildings and landscapes is an integral part of planning for repair and maintenance.
2. Employ the least intrusive methods of stabilization and repair when dealing with historic building fabric.

3. Retain original fabric and character-defining features. Missing original features should be replicated faithfully without reproducing original failures or shortcomings.
4. The University should maintain its staff of skilled tradespeople who are knowledgeable in traditional materials and construction practices and are capable of performing maintenance and repairs in a manner which is equal to or better than that found in the original construction of historic buildings.
5. Completed work must visually match work from the resource's period of significance.
6. Photographic and written documentation should be incorporated into all phases of work conducted on historic buildings and landscapes.

2.4 ADAPTIVE USE OF BUILDINGS AND LANDSCAPES

Improvements and alterations to historic resources should have minimal effect on the integrity of the building and/or landscape while extending the life and use of the resource. Alterations to accommodate ephemeral uses and occupancy should be reversible. Permanent improvements to accommodate changes in use should be executed to a degree of quality equal to or exceeding that of the original construction.

1. Evaluate the effect of proposed alterations to the integrity of the historic resource based on the significance of the building or landscape in question.
2. Consider the original design of a building or site and its significant features when planning for reuse or adaptation. Ideally the use of buildings should be compatible with their original function/plan to minimize changes to layout.
3. Ensure the installation and/or replacement of services and systems does not adversely affect the integrity of buildings and landscapes.
4. Reverse past alterations that detract from the integrity of the historic resource when circumstances allow.
5. Mothball vacant or underutilized historic buildings according to standards put forward by the National Park Service in Preservation Brief 31 to protect structures from deterioration and maintain them until appropriate use allows for their occupancy and repair.
6. Architectural fragments, significant elements and pieces of building systems removed from structures should be recorded, archived, and protected for future research and study.

2.5 ARCHAEOLOGICAL CONCERNS

On occasion, the University discovers subsurface archaeological materials requiring immediate, expedient investigation as to their merits and the means by which they will be removed or preserved. It is the University's responsibility to advise the A/E of known or suspected sites having archaeological significance, as well as the intent of the University to perform an archaeological investigation.

In the event of a discovery during construction, notify the Project Manager immediately and he/she will make provisions for site investigation.

Chapter 3 Sitework

3.1 SITEWORK GENERAL

3.1.1 INTRODUCTION

The Project Manager shall coordinate review of all projects involving sitework or landscaping with the University Landscape Architect, FM Landscape Services, the Arboretum and Landscape Committee, and the Department of Safety and Security. Coordinate exterior signage with the Office of the Architect for the University, the Office of the University Building Official, and the UVA Fire Marshall. Coordinate site utilities with the FM Department of Energy and Utilities.

Other sections affecting sitework and landscape design include: 1.3.2 Stormwater Management / Erosion and Sediment Control, 1.4.4.1.2 Asbestos Removal, 1.4.4.2 Special Procedures for Lead Containing Paint, and 5.5.7 Rooftop Equipment.

3.1.2 CONSTRUCTION SITE FENCING

Standard construction site fencing should be 8' chain link fencing with a top rail and green vision screening. For projects in the Central Grounds that are highly visible and with a duration exceeding one year, the Project Manager should consult with the building committee to consider the use of UVA 8' plywood fence and associated details.

3.2 SITE PREPARATION

3.2.1 SITE CLEARING AND BUILDING REMOVAL

Collect all logs, stumps, brush, wood and refuse, and divert from the landfill for beneficial use (e.g., compost or mulch). On-site burning is prohibited. The Project Manager, via state permit application by Geospatial Engineering Services and in collaboration with the Office of the Architect and Real Estate, shall obtain required State approval for building removal. The University shall perform an asbestos and lead-based paint survey, and this information shall be included in the construction documents.

3.2.2 DUST, MUD, AND DIRT CONTROL

The site shall be prepared in accordance with 1.3.2 Stormwater Management Stormwater Management / Erosion and Sediment Control. This includes controlling dust, dirt, and mud. The regulations governing sediment control can be found in the Erosion and Sediment Control regulations 9VAC25-840 et seq. as amended. Regulations governing dust emissions can be found in 9VAC5-40-90 and 9VAC5-50-90.

3.2.3 PLANT PROTECTION

Trees, shrubs and planting beds within the Contract Limit Lines are to be protected with rigid fencing (wood or chain link) to prevent damage from external construction activities. Tree protection shall be located, at a minimum, at the dripline of the tree canopy. Tree protection fencing is to be installed

prior to any other activity occurring on the site and is to remain in place until final inspection. Selection of trees to be protected and tree protection shall be coordinated through the Facilities Management Landscape Superintendent. All tree removal requires prior approval by the Office of the Architect for the University and/or the Arboretum and Landscape Committee. The parking of vehicles, construction access, and storage of any construction materials shall not occur under the driplines of trees to be protected.

3.2.4 EARTHWORK

Earthwork specifications shall include soil and aggregate material definitions for all materials used on the project. The soil materials shall be defined by a recognized soil classification system, such as the Unified Soil Classification System or the AASHTO Soil Classification System. The aggregates shall include gradations required for each material.

3.2.4.1 GEOTECHNICAL REPORT

A Geotechnical/Soils Report shall be included in the Appendix to the Specifications as well as a disclaimer stating that the report is not part of the construction documents. The report should include the following:

1. Subsurface profiles (boring logs) and limits showing the extent of rock, existing fill materials, water and existing unsuitable bearing materials;
2. A statement noting whether over-excavation and replacement with suitable materials is required;
3. Definition of suitable materials for structural fill, general fill and backfill. Note: Suitable materials that become saturated are not automatically rendered unsuitable;
4. For projects requiring a stormwater management plan, site soils should be classified in accordance with the US Department of Agriculture's hydrological soil group criteria;
5. The Geotechnical Report/Engineer shall set a tolerance from the optimum moisture content to account for field conditions during construction.

3.2.4.2 EARTHWORK SPECIFICATIONS

1. Specifications for fill materials shall state whether they are included in the Base Price/Bid or will be an extra cost item.
2. Rock excavation shall be included in the Base Price/Bid to the extent that locations are sufficiently identified in the Geotechnical/Soils Report.
3. The specifications shall list the tests required (i.e. ASTM, AASHTO, VDOT, or other test procedures) and stipulate the values to be achieved.

3.3 SITE DEVELOPMENT

3.3.1 PLANTING

The selection of plant material and the planting and maintenance of trees, shrubs and herbaceous plants must be consistent with the current American Standard for Nursery Stock (AAN). Warranty period is one year minimum. The contractor's responsibilities include the protection of plantings, pest control, pruning, watering and plant material during warranty period. All plant material soil conditions must be inspected by the Facilities Management Landscape Superintendent.

Capital and minor capital projects that include a site or landscape plan in the scope must provide an approved Site Safety Plan that coordinates plantings, landscape design, camera views, site lighting, e-

phones, and fire/emergency vehicle access. The Site Safety Plan will require consultation with the OAU Landscape Architect, Director of Safety and Security Systems and Technology, Associate Director of Grounds, the University Fire Marshall, and shall include:

1. Crime Prevention Through Environmental Design (CPTED) strategies to promote holistic site safety;
2. Consideration of the site's evolving characteristics through time of installation through vegetation maturity;
3. Coordination of site lighting and plantings such that plantings do not interfere with illumination of pathways, site stairs, and building entrances;
4. Coordination of lighting and plantings such that plantings do not block a camera's intended view;
5. Design and specification of plantings to avoid creating hiding places near pathways and building entrances. Shrub species selections shall not exceed 3' in height along pathways and at building entrances for a typical buffer of at least 10';
6. Design and specification of plantings to avoid vegetation encroaching into buildings:
 - a. Shrub plantings, at maturity, should not grow above windowsills
 - b. Trees, at maturity, should not grow into building facades

3.3.1.1 SOIL PREPARATION

Soils in areas to be planted that are compacted above 85% maximum density shall be mechanically loosened to a minimum uniform depth of 24" below final grade. Inadequate soil conditions must be addressed prior to planting.

3.3.1.2 PLANTING PROCEDURES

The width of each planting hole should be three times the size of the root ball. The depth of the hole shall be 2" less than the distance from the bottom of the root ball to the root collar. The bottom and sides of the each hole should be scarified to encourage root development. Upon planting, all plants must be inspected to ensure that the root collar is exposed.

3.3.2 PAVING AND CURBS

Minimum slope for all paved surfaces shall be 1%. Maximum slopes for streets, service drives and parking lots shall be 8%. Guidance on acceptable paver types may be found in Office of the Architect for the University-Landscape Typologies & Standards (OAU-LTS), linked from the OUBO website (<https://oubo.virginia.edu/udg.html>).

Curbs shall comply with the 6" Virginia Department of Transportation (VDOT) CG-2 Standard. Painted striped crosswalks shall be provided at all road intersections. Curb ramps shall comply with VDOT CG-12 Standards; detectable warnings shall be safety yellow (exceptions made for Historic Grounds). The use of pervious paver systems over impervious is encouraged whenever possible.

Pavement thickness at utility trenches shall be a minimum of one-and-one-half times existing pavement thickness or, as noted above, whichever is higher. Backfill in utility trenches under pavements shall be VDOT #21A above top of bedding to underside of pavement.

Unless modified by documented site conditions and geotechnical recommendations, asphalt paving shall be:

Course/VDOT Specification	Roads	Parking	Pedestrian walks
Surface/SM-9.5A	2"	1 ½ "	2"
Binder/ BM-25.0A	3"	2"	Not applicable
Sub-base/21A	10"	6"	6"
Sub-grade compaction	*98%	95%	95%

**Maximum dry density (ASTM D698, Method D)*

3.3.2.1 FIRE APPARATUS ACCESS ROAD AND LOADING

Buildings shall be accessible to fire department apparatus by way of an approved access road with an asphalt, concrete or other approved driving surface capable of supporting the imposed load of fire apparatus weighing at least 85,000 pounds. Fire apparatus access roads shall be of an all-weather surface that is easily distinguishable from the surrounding area. The use of reinforced turf or similar material for roadway surface is prohibited. Fire apparatus access roads shall have an unobstructed driving surface width of not less than 20 feet (26 feet adjacent to fire hydrants) and an unobstructed vertical clearance of not less than 13 feet 6 inches. The fire code official shall have the authority to require an increase in the minimum access widths where they are inadequate for fire or rescue operations. Documentation from a registered engineer that the final construction is in accordance with approved plans or the requirements of the Fire Code may be requested.

3.3.3 SIDEWALKS AND STAIRS

The choice of sidewalks shall be in consultation with the University Landscape Architect. Sidewalks will be separated from curbs by planting areas for pedestrian safety, except where restricted by urban site needs.

See Appendix A Figure 9 for concrete sidewalks. The color for concrete shall be Canvas by Soloman as specified in OAU-LTS. Any other color shall be approved by Office of the Architect for the University. Where sidewalks abut existing structures, expansion joints shall be provided. Brick sidewalks shall be constructed on concrete per Appendix A Figure 10. Provide positive drainage 1.5% to 2.0% to prevent water accumulation on exterior stairs. Where post-mounted handrails occur, detail the embedment to minimize deterioration of the posts and/or the concrete slab.

3.3.4 EXTERIOR SITE FURNISHINGS

See the Office of the Architect Landscape Typologies + Standards document for design standards for EXTERIOR FURNISHING, BICYCLE RACKS, BENCHES and BOLLARDS. See UVA's Waste Infrastructure Design Requirements for specification standards for RECYCLING and TRASH RECEPTACLES. For both standards, see links on the OUBO website (<https://oubo.virginia.edu/udg.html>).

Chapter 4 Energy and Utilities

4.1 OVERVIEW

The Energy and Utilities at UVA Charlottesville are based on a district energy model. All utilities to a proposed building site are to be furnished from University central distribution systems, unless either unavailable or demonstrated to be impractical in terms of design or cost. Utilities not available or impractical from central distribution systems must be generated at the proposed building.

Specifications shall include requirements which result in alterations or connections to any University domestic water, steam, hot water, chilled water, sanitary, storm, electrical (power and exterior lighting), plumbing, and exterior utilities distribution, shall be coordinated with Facilities Management Energy & Utilities Department through the Project Manager.

4.1.1 UNDERGROUND UTILITY SEPARATION

In addition to applicable code requirements for domestic water, a minimum of 12" vertically and 12" horizontally, wall-to-wall, shall be provided between any two utilities and utilities structures.

4.1.2 UTILITY TRENCH CUTS IN ROADWAYS

Utility trench cuts in roadways shall be limited to 200' maximum and shall be covered with traffic-rated steel plates at the close of construction activities each day and/or properly barricaded throughout construction.

4.1.3 UNDERGROUND UTILITY OFFSETS

New underground utilities shall not be placed within the dripline of existing trees without approval and coordination by the Office of the Architect and FM Landscape Services. Utilities shall be installed using directional boring with boring pits located outside the tree dripline. Open trenching is discouraged within the dripline. If approved within 10' of existing trees, use HDPE butt-welded pressure piping. Coordinate root and soil protection with the Landscape Superintendent.

New shade trees shall not be planted in the following setbacks. Removal of existing trees within these setbacks requires approval:

1. Within 10' of existing water bearing lines (domestic, chilled, medium temperature)
2. Within 10' of existing gas lines
3. Within 10' of existing sanitary or storm lines with joints, or within 5' of existing sanitary or storm lines without joints
4. Within 5' of communication lines
5. Directly over ductbanks

4.2 STORM SYSTEMS

See section 1.3.2 Stormwater Management / Erosion and Sediment Control for projects required to address stormwater management.

4.2.1 BUILDING AND ROOF DRAINAGE

Drainage piping shall be located as approved by the Facilities Management Energy and Utilities Department and other applicable authorities when located in streets, right-of ways or easements not on University property. All building roof drainage, including external downspouts, areaway drains, and foundation drains shall be connected to a storm water management practice, cistern or the storm sewer system.

If connecting to the storm sewer system, connections shall preferably be made to a storm utility vault or a drop inlet directly. Where the preferred connection is not feasible or economically justified, the connection shall be to the storm sewer with a “Y” a maximum of 50’ away from the building. Provide cleanout at roof drain and at a change in direction of any drainage piping. Where a storm system is not available, a new system shall be provided.

Parking garages or buildings with embedded parking decks having areas exposed to precipitation shall be provided with area drains and/or trench drains for capturing stormwater runoff. Covered parking levels are to be provided with sanitary sewer drain connections and no storm sewer connections. The design team shall coordinate with Parking and Transportation regarding any infrastructure needs to support parking deck maintenance (e.g. washing operations).

4.2.2 STORM INLETS AND STRUCTURES

The following requirements apply to storm inlets and structures:

1. Virginia Department of Transportation (VDOT) standard structures are to be used. In historic areas, smaller dimensioned structures may be approved on a case-by-case basis.
2. Curb inlets shall be used for all surface drainage for roadways and parking lots unless vegetated swales or bio retention filters are used
3. All grates for yard inlets shall meet handicapped accessibility standards.
4. Grate inlets shall be used for all lawn areas.
5. Dome top inlets are preferred in landscaped areas.
6. Inlet grates shall be bicycle-safe and orientated with the long axis perpendicular to the direction of traffic.
7. The tops of all structures shall be flush with the pavement surface.
8. Inlet structure grating shall be heavy-duty traffic rated providing a minimum 24” clear opening for access. No type of concrete or brick filled cover shall be used. This includes storm and sanitary structure covers, clean outs and valve boxes. Powder coating may be accepted with prior approval from the University Architect and E&U.
9. For pipe diameters up to 18” or a depth of 4’-0”, the minimum inside size for drop inlets shall be 24”. For pipe diameters greater than 18” or deeper than 4’-0”, drop inlets shall be 48”

Area drains, clean outs and yard drains with minimum pipe size and cover shall use shallow cast iron fittings or heavy-duty HS 20 traffic fittings.

Provide storm structures for storm systems adjacent to all buildings to which laterals from the building are directly connected. Laterals shall be a maximum of fifty feet (50’). The cleanouts shall be installed in a concrete pad flush with the surface and be HS-20 rated. Storm structures shall occur at changes in direction and in straight runs at a maximum of four hundred feet (400’). Storm structures shall have a minimum inside diameter of 48” with shaped flow troughs at the bottom. Storm structure frame and cover shall be HS-20 rated and shall provide a minimum 24” clear opening for access. Joints in precast utility vaults – inside and out – shall be filled with non-shrink grout and finished smooth. Storm structures shall be coated from the outside with a bitumastic/coal tar based waterproof coating. Pipe connections to storm structures shall be made with flexible rubber boots. At existing structures, install sleeves prior to connections.

4.2.3 SITE STORM SYSTEMS

Storm mains shall be a minimum of 15" in diameter. Lines serving yard drains shall be 8" to 12". Roof, area and foundation drains shall be 4" to 6" for single drain laterals and 8" to 12" for multiple drain collector laterals.

HDPE double-walled corrugated pipe is preferred for all applications. Class III Reinforced Concrete Piping (RCP) is acceptable for all applications. Foundation and retaining wall drains shall be perforated solid wall schedule 40 Polyvinyl Chloride (PVC) with solvent joints wrapped in geotextile fabric with a VDOT #10 (stone dust) bed and cover. Under slab drains can be corrugated PVC.

A minimum cover of 24" shall be provided for storm piping. All buried storm lines shall have VDOT #10 (stone dust) or VDOT Sand – Type A bed and cover. The minimum slope shall result in a self-cleaning velocity (2 fps minimum) for the diameter used. Pipe on a 20% or greater slope shall be secured with concrete anchors.

4.3 SANITARY SYSTEMS

The University owned sanitary sewerage system connects to city-maintained sewerage lines and the Rivanna Water and Sewer Authority's treatment plants.

4.3.1 SITE SANITARY SYSTEMS

Sanitary pipe shall be a minimum of 4" for laterals and 8" for mains. Sanitary piping shall be cast iron (CI), ductile iron (DI), HDPE pressure pipe, or solvent weld jointed schedule 40 PVC. HDPE and PVC are not allowed above grade at the Heating Plant. A minimum cover of 36" shall be provided for sanitary piping.

4.3.2 SANITARY UTILITY STRUCTURES AND CLEANOUTS

Provide utility structures on sanitary systems adjacent to all buildings to which laterals from the building are directly connected. Where sanitary laterals exceed 20', a clean out shall be provided just outside the building. Laterals shall be a maximum of fifty feet (50'). The cleanouts shall be installed in a concrete pad flush with the surface and be HS-20 rated.

Utility structures shall occur at changes in direction and in straight runs at a maximum of 200'. Utility structures shall have a minimum 48" inside diameter with shaped flow troughs at the bottom. Utility structure frame and cover shall be HS-20 rated, providing a minimum 24" clear opening for access. No type of concrete or brick filled cover shall be used. This includes storm and sanitary structure covers, clean outs and valve boxes. Powder coating may be accepted with prior approval from the University Architect and E&U.

Utility structures with an invert change of 18" or two times the inlet pipe diameter—whichever is greater— shall be provided with drop piping outside the utility structure. Joints in precast utility structures (inside and outside) shall be filled with non-shrink grout and finished smooth. Utility structures shall be coated from inside with vapor/moisture penetration preventing epoxy coating and from the outside with bitumastic/coal tar based waterproof coating.

Pipe connections to utility structures shall be made with flexible rubber boots. At existing structures install sleeve prior to connection. Use flexible, mechanical clamps, grout and water stop for a leak-proof connection.

All sanitary utility structures shall be vacuum tested at 10 inches of mercury per the table below:

Depth of Utility Structure	Diameter of Utility Structure (Feet)	
	4 feet	6 feet
Feet	Time (Seconds)	Time (Seconds)
<14	60	60
16	60	67
18	60	73
20	60	81
22	60	89
24	60	97
26	64	105
28	69	113
=>30	74	121

The vacuum test method shall be in accordance with ASTM C1244-05a, except as specified otherwise herein.

4.4 EXTERIOR DOMESTIC AND FIRE SERVICE WATER PIPING

Underground domestic water distribution pipe shall be HDPE Dimension Ratio (DR)11 piping (preferred) or asphalt coated, cement lined ductile iron, Class 52 or higher with flexible restrained joints. All hardware for ductile iron piping shall be epoxy coated. All fittings for HDPE shall be molded fittings. If fabricated fittings are used the DR must increase to maintain the pressure rating. When sizing piping, ensure the inside diameter of the piping is used to meet necessary flow requirements. Branch lines 2" and smaller can be type K copper with silver soldered joints or HDPE. All mains (piping serving more than one building) shall be a minimum of 6" diameter. The entry point into buildings shall be made with factory flanged ductile iron pipe, class 53 or higher or HDPE.

New domestic water branches shall be connected to existing mains with full size tees. Full size resilient seat gate valves shall be provided on the branch line, the downstream side of the tee and the upstream side of the tee. Coordinate valve locations with the Energy & Utilities Department. All valves with the operating nut greater than 24" below grade shall be provided with valve extensions.

All piping shall have VDOT #10 (stone dust) or a VDOT Sand – Type A bed and cover. Provide a minimum of 3'-0" cover. All buried HDPE domestic lines shall be pressure tested at in accordance with ASTM International F 2164, Standard Practice for Field Leak Testing of Polyethylene (PE) Pressure Piping Systems Using Hydrostatic Pressure. All ductile iron piping shall be pressure tested at 200 psig for two hours. All domestic water lines shall be bacteria tested per ANSI/AWWA C651- 14 – Disinfecting Water Main Standard. Underground fire service piping shall be tested and approved in accordance with the current edition of NFPA 13. FDC Automatic ball drip must be accessible for inspection and testing. Minimum access clear opening for ball drip shall be minimum 24".

Discharges of water from disinfection and bacteria testing shall follow UVA's Dechlorination SOP as appropriate. The full procedure is available at the website for UVA Environmental Resources, Standard Operating Procedures to Prevent Pollution, or linked from the OUBO website (<https://oubo.virginia.edu/udg.html>).

4.5 EXTERIOR CHILLED WATER PIPING

Underground chilled water distribution pipe shall be HDPE DR11 (preferred), or asphalt coated, cement lined ductile iron, Class 52 or higher with flexible restrained joints. All hardware for ductile iron piping shall be epoxy coated. All fittings for HDPE shall be molded fittings and if fabricated fittings are used the DR must increase to maintain the pressure rating. When sizing piping, ensure the inside diameter of the piping is used to meet necessary flow requirements. All mains shall be a minimum of 6" interior diameter.

New chilled water branches shall be connected to existing mains with full size tees. Full size resilient seat gate valves shall be provided on the branch line as well as the downstream side of the tee and the upstream side of the tee. Coordinate valve locations with the Energy & Utilities Department. All valves with the operating nut greater than 24" below grade shall be provided with valve extensions.

Buried HDPE chilled water piping does not require insulation. Buried ductile iron supply piping shall be insulated with 1" of field installed rigid foam glass with a 50 mil poly jacket.

All buried chilled water lines shall have VDOT #10 (stone dust) or a VDOT Sand – Type A bed and cover. Chilled water lines shall have a minimum 4'-0" cover. All buried domestic lines shall be pressure tested at in accordance with American Society of Testing and Materials (ASTM) International F 2164, Standard Practice for Field Leak Testing of Polyethylene (PE) Pressure Piping Systems Using Hydrostatic Pressure.

4.6 EXTERIOR DOMESTIC HOT WATER

The University is working to eliminate distributed domestic hot water systems by providing dedicated domestic water heating systems for each building. Parts of the University continue to receive distributed domestic hot water from various sources. These systems include:

- Hereford College
- Alderman Road Residence Halls
- The Lawn
- West Complex

For domestic water heating systems, all direct buried pipe shall comply with the following:

1. The carrier pipe shall be type K copper with a 15% (minimum) silver soldered joints or approved plastic piping. Coordinate with the Energy & Utilities Department.
2. The back fill material shall be VDOT Sand – Type A (preferred) or VDOT #10 (stone dust).

4.7 PETROLEUM STORAGE TANKS

All petroleum tanks, aboveground storage tanks (ASTs) and underground storage tanks (USTs), must be double-walled, and all associated underground piping must be double-walled.

Drawings and specifications for any tank, either AST or UST, shall be reviewed and approved by the University Environmental Resources for compliance with Department of Environmental Quality (DEQ) requirements and the University's more restrictive EPA Spill Prevention, Countermeasures and Control plan. Documentation of Environmental Resources approval is required prior to issuance of a building permit.

Copies of as-built tank drawings, inspection reports, and passing test results for tank components shall be provided by the Project Manager to Environmental Resources to document compliance with regulatory requirements. DEQ additionally requires the University to obtain building permits from the University Building Official for removal and replacement of tanks. The DEQ also requires that ASTs over 660 gallons and regulated USTs (motor fuel and generator fuel) be registered. All required registration information

must be supplied by the contractor.

Technical standards related to storage tanks are contained in the State Water Control Board Regulations: 9VAC25-580 Underground Storage Tanks (UST): Technical Standards and Corrective Action Requirements and 9VAC25-91, Facility and Aboveground Storage Tank (AST) Regulation, and in federal regulations 40 CFR 112 pertaining to Spill Prevention Control and Countermeasures Plans (SCCC).

4.8 OIL INTERCEPTORS

Oil interceptors shall be provided for drainage areas including mobile vehicle fueling or outdoor vehicle wash stations. Interceptors shall be designed according to established standards for size and water quality control. There shall be adequate access for cleaning all areas of the separator with a vacuum pump and compartments shall be constructed horizontally. A minimum of one access point into each compartment within the separator shall be provided. Access points shall be no further than 10' apart, regardless of the number of compartments. Access covers shall have a minimum opening dimension of 24" in diameter.

4.9 NATURAL GAS

Natural gas is available from the Gas Division of the Charlottesville Department of Public Works for distribution and shall be coordinated through Energy & Utilities Department. See Chapter 7: Building Services for additional information.

4.10 HEATING SYSTEMS

4.10.1 SOURCES

1. It is the intent of the University to minimize the expansion of or additions to the existing steam system. If new steam piping is being proposed, the project team must coordinate the request and requirements with Energy and Utilities. High Pressure Steam (HPS) is available to most UVA Health (Hospital and Medical School) buildings at 180 psig. All HPS piping shall be designed for 270 psig saturated steam (413°F). Steam is generated year-round at the Central Heating Plant. Steam shall NOT to be used as primary building heat where medium temperature hot water is or can be made available. Steam or Medium Temperature Hot Water (MTHW) shall be used for summer humidity control where required. Steam shall also be used, via a heat exchanger (steam-to-steam or steam-to-water) for process use in laboratories, food preparation areas and domestic hot water generation systems. Central steam shall not be directly used for heating, humidifying, or sterilizing. The maximum designed steam velocity shall be 7,200 feet per minute. High pressure steam from the University system shall be dropped to low pressure steam in a two-stage PRV station; the University defines the intermediate stage, usually 60 to 80 psig, as Medium Pressure Steam.
2. Heating Hot Water: See Appendix A (Figure 11B) for plant supply and return water temperatures and seasonal reset schedules.
 - a. MTHW is defined as heating water between 170°F – 230°F. The University maintains two MTHW loops, one originating at the Central Heating Plant and the other from the Massie Road Plant.
 - b. Low Temperature Hot Water (LTHW) is defined as heating water below 170°F: The University maintains two LTHW loops, one originating at the North Grounds Mechanical Plant and the other from the Ivy Mountain Central Utility Plant. Some additional areas of the Grounds are served with distributed LTHW. Buildings served with distributed LTHW shall have distribution pumps serving the building and do not require blending loops or isolation heat exchangers.

4.10.2 STEAM AND HOT WATER TUNNELS AND DISTRIBUTION SYSTEMS

It is the intent of the University the move away from designing and installing new tunnel systems for Utilities. Where existing utility tunnels exist, it is the intent to reuse the existing tunnel for the modification, replacement, or installation of piping in these locations. All new piping systems to be installed outside the footprint of an existing tunnel are to be direct buried.

4.10.2.1 STEAM SYSTEMS

Main HPS service entrances shall have a block and bleed valve assembly. Steam Pressure Reducing Valves (PRV) shall be cast steel. Spence, Sarco and Armstrong are acceptable manufacturers for steam PRVs. The first stage PRVs shall be Class 300.

Steam strainers shall be installed horizontally so condensate does not collect.

Inverted bucket traps shall not be used. Float & Thermostatic traps are preferred for equipment loads and drip on low pressure and medium pressure steam. Bimetallic traps are preferred for drip on HPS. Equipment traps shall have bypasses; drip traps shall not. Provide ¼" test ports with ball valves just upstream of the check valve after all steam traps. Provide a steam trap monitoring device on the condensate line downstream of equipment traps and program to alarm on detection of live steam or sub cooled condensate.

Specify pressure powered condensate pumps rather than electric. Pressure powered pumps shall be sized to operate with medium pressure steam. Electric condensate pumps where used shall be on emergency power.

4.10.2.2 STEAM PIPING, FITTINGS, AND VALVES

All HPS, high pressure drip, pumped condensate pipe including direct buried/pre- insulated piping systems shall be A-106 seamless, fittings shall be class 300 malleable iron, cast steel or forged steel (not cast iron); flange bolts shall be grade B7 and flange gaskets shall be spiral wound metal or spiral wound polytetrafluoroethylene (PTFE) that is rated for at least 500°F. Steam and condensate pipe/valves 1" and smaller can have threaded joints, larger pipe shall have socket weld or butt weld joints. All steam condensate lines shall be Schedule 80 and all fittings on condensate lines shall be Class 300. Materials of construction and fabrication must lie within allowable stress values specified by the American Society of Mechanical Engineers (ASME) Code. Design life will be 30 years.

For steel, pre-insulated/direct-buried pipe the following shall apply for all steam pressures, and condensate:

1. Shut off valves shall be provided on direct buried system on the downstream legs of all tees and just outside buildings that are more than 100 feet from the nearest shut off valve. The gear operated valves shall be in a precast concrete utility structure or direct buried where approved by UVA Energy and Utilities.
2. The jacket shall be extruded HDPE with a minimum wall thickness of 125 mils on pipe up to 12" and 150 mils for larger pipe and a water stop between each section of carrier pipe. All HDPE on any project shall be provided by the same manufacturer. The jacket shall be pressure tested prior to backfilling. A leak detection wire shall be provided inside the jacket.
3. The insulation on steam systems shall be rated for at least 700 degrees, regardless of the steam pressure.
4. The back fill material shall be VDOT Sand – Type A (preferred) or VDOT #10 (stone dust).
5. Consult with Energy & Utilities for additional information and requirements

Valves on the 2 ½" and larger high-pressure steam and pumped condensate shall be cast steel class 300 high performance lugged butterfly valves with M-filled PTFE, reinforced polytetrafluoroethylene (RTFE) or Xtreme seat and seals with double or triple offset seats. Valves for HPS shall be rated for 270 psig saturated steam (413°F). Acceptable manufacturers for high performance butterfly valves are Adams, Bray, Jamesbury, and Zwick. All sizes of butterfly valves on all steam pressures shall have gear operators.

Valves on 2" and smaller high-pressure steam and pumped condensate, shall be cast steel class 300 high performance full port flanged ball valves with carbon steel body, stainless steel ball and stem, and M-filled PTFE, RTFE or Xtreme seat and seals and gear operator, Valves for HPS shall be rated for 270 psig saturated steam (413°F). Acceptable manufacturers for high performance ball valves are Adams, Bray, Jamesbury, and Zwick.

Valves on all steam traps, vents, and drip legs shall be 800 lb. welded bonnet gate valves. 100% of welds shall be X-Ray weld tested.

4.10.2.3 HEATING HOT WATER PIPING, FITTINGS, AND VALVES

All MTHW/LTHW pipe shall be:

- Direct buried/pre-insulated piping systems A-106 seamless, fittings shall be class 300 malleable iron, cast steel or forged steel (not cast iron); flange bolts shall be grade B7 and flange gaskets shall be spiral wound metal or spiral wound PTFE that is rated for at least 500°F. Materials of construction and fabrication must lie within allowable stress values specified by the ASME Code. Design life will be 30 years.
- Cross-linked polyethylene (PE-Xa), if the piping system meets the UVA provided heating water loop temperature and pressure requirements. Design life will be 30 years.
- Plastic piping system which meets the UVA provided heating water loop temperature and pressure requirements. Design life will be 30 years. Coordinate and verify requirements with Energy & Utilities.

The following shall apply for all heating hot water piping systems (unless otherwise stated):

- New branch lines shall be connected to existing mains with full size tees. Full size resilient seat gate valves shall be provided on the branch line as well as the downstream side of the tee and the upstream side of the tee. Coordinate valve locations with the Energy & Utilities Department. All valves with the operating nut greater than 24" below grade shall be provided with valve extensions. Pre-insulated ball valves for steel piping and resilient seated gate valves rated for 250 psi at 250°F for all other piping shall be provided on the branch line as well as the downstream side of the tee.
- For steel piping systems, the jacket shall be extruded HDPE with a minimum wall thickness of 125 mils on pipe up to 12" and 150 mils for larger pipe and a water stop between each section of carrier pipe. All HDPE on any project shall be provided by the same manufacturer. The jacket shall be pressure tested prior to backfilling. A leak detection wire shall be provided inside the jacket.
- For steel piping systems, pre-insulated/direct-buried pipe, the insulation shall be rated for at least 250°F regardless of the actual temperature of the fluid.
- The back fill material shall be VDOT Sand – Type A (preferred) or VDOT #10 (stone dust).
- For steel piping, 100% of welds shall be X-Ray weld tested.
- See **4.11** Flushing Requirements for heating water flushing requirements.
- Consult with Energy & Utilities for additional information and requirements.

Above-grade MTHW systems, valves shall be:

- Butterfly valves: Cast steel class 150 high performance lugged butterfly valves with M-filled PTFE, Xtreme or better seat and seals with double offset seats and gear operator. Valves for MTHW shall be rated for 250 psig and 400°F.
- Ball valves: Cast steel class 150# high performance full port flanged valves with carbon steel body, stainless steel ball and stem, and M-filled PTFE seat and seals and can be used on lines up to 4". Valves on pipe 2" and smaller shall be socket weld or threaded joints. Valves for MTHW shall be rated for 250 psig and 400°F.

Above-grade LTHW systems, valves shall be:

- Butterfly valves: Cast steel class 150 high performance lugged butterfly valves with M-filled PTFE, Xtreme or better seat and seals with double offset seats and gear operator. Valves for LTHW shall be rated for 250 psig and 400°F.
- Ball valves: Cast steel class 150 high performance full port flanged valves with carbon steel body, stainless steel ball and stem, and M-filled PTFE seat and seals. Valves on pipe 2" and smaller shall be socket weld or threaded joints. Valves for LTHW shall be rated for 250 psig and 400°F.

The first set of valves after piping has entered the building shall meet the associated MTHW/ LTHW piping and valve requirements of the system of which they are connected.

4.10.2.4 EXPANSION JOINTS (STEAM AND HOT WATER)

Expansion joints on heating pipe shall be class 300 packed slip type or ball joints, packable under pressure. Bellows type expansion joints shall not be used. Expansion joints on HPS, pumped condensate and MTHW shall have welded joints rather than flanges. Where appropriate slip expansion joints with an integral foot can be used in lieu of an expansion joint and separate anchor. Acceptable manufacturers are Adscos, Advanced Thermal Systems and Yarway.

Provide calcium silicate insulation on the main body of the expansion joints and provide a removable flexible insulation blanket that overlaps the calcium silicate by 4" on each side. Install slip expansion joints so the pipe expands into the joint in the direction of flow. Install ball joints in the direction of flow per the manufacturer's instructions.

4.10.2.5 INSULATION

Insulation in steam and MTHW tunnels shall be fiberglass rated for 800°F or calcium silicate with aluminum jacketing (color to match existing systems); applied to fittings with waterproof adhesive and copper or stainless-steel wires.

4.11 FLUSHING REQUIREMENTS

All new chilled water and heating water systems shall be flushed prior to operation. Coordinate chemical types used with UVA and the water treatment vendor. Notify UVA 30 days prior to commencing system flushing. Provide a flushing report indicating:

1. Date of initial treatment
2. Type of chemical(s) used
3. Duration of flushing

4.11.1 CARBON STEEL PIPING

The system shall be pre-flushed, flushed, passivated, rinsed and filled with treated water.

4.11.1.1 PRE-FLUSH

Provide bypasses at each strainer, control valve, coil, heat exchanger, and pump. Provide dedicated pump and inline strainer for system flushing.

4.11.1.2 CLEAR WATER

Fluid Velocity: 5 ft/sec minimum Filtration: 50 microns minimum

Duration: Until system water is comparable to makeup water and iron content is less than 2.0 ppm.

4.11.1.3 CLEANING AND PASSIVATION

Fluid Velocity: 3-5 ft/sec

Duration: 24 hours minimum.

4.11.1.4 FINAL RINSE

Continuously flush the system, discharging chemicals into an approved sanitary system. Makeup water is to be supplied simultaneously, preventing air from entering the system, while diluting the treated water.

Duration: Until conductivity level is reduced to the makeup water conductivity levels.

Filtration: 5 microns minimum

4.11.1.5 FINAL CHEMICAL FILL

Inject final chemicals into the system and circulate the fluid, ensuring water is not left stagnant.

4.11.2 PLASTIC PIPING

4.11.2.1 PRE-FLUSH

Provide bypasses at each strainer, control valve, coil, heat exchanger, and pump. Provide dedicated pump and inline strainer for system flushing.

4.11.2.2 CLEAR WATER FLUSH

Fluid Velocity: 5 ft/sec minimum

Filtration: 5 microns minimum

Duration: Minimum 1 hour per 1,000 ft of linear pipe and until system water is comparable to makeup water.

4.11.2.3 FINAL CHEMICAL FILL

Inject final chemicals into the system and circulate the fluid, ensuring water is not left stagnant.

4.12 POWER & LIGHT

4.12.1 SITE LIGHTING

All exterior steps, roadways and main pathways shall be lighted. See also 3.3.1 Planting.

4.12.1.1 DESIGN REQUIREMENTS

1. Voltage drop calculations for site lighting circuits shall be provided with the contract document

submission. Circuit wire sizes shall be such that site lighting voltage drops do not exceed 2% for new site lighting circuits and 3% total for existing circuits to which lights are added.

2. Point-by-point foot-candle calculations of the site lighting shall be provided with the contract document submission; foot-candle calculations shall include the Illuminating Engineering Society (IES) design level/classification used. Unless noted otherwise below, all lighting levels and ratios shall be per IES standards and Virginia Uniform Statewide Building Code (VUSBC).

Illumination Requirements			
Location/Area	Horizontal fc levels*	Vertical fc levels*	Ratio
Parking Primary walks, ramps, and pedestrian areas	1.0 avg, 0.25 min	0.5 – 0.8 avg	4:1 avg to min
Secondary walks, ramps, and pedestrian areas	0.5 avg, 0.15 min	0.5 – 0.8 avg	4:1 avg to min
Exterior steps	1.0 avg, 0.25 min	none	4:1 avg to min

* Horizontal and Vertical foot-candle (fc) levels are measured at grade.

3. Light pollution: See Section 8.2.2.2 Prescriptive Requirements.

4.12.1.2 LIGHT FIXTURE REQUIREMENTS

All exterior lighting fixtures shall use LED lamps only. Lens shall be impact-resistant tempered glass with a minimum 0.125” thickness. All new or replacement exterior lighting in proximity to the University’s Astronomy Observation Facilities shall be reviewed by the Department of Astronomy. See Appendix A Figure 8 for this Observatory-Sensitive Zone.

4.12.1.3 LIGHT FIXTURES AND SPECIAL REQUIREMENTS FOR ON-GROUNDS FACILITIES

All exterior lighting fixtures on Grounds shall conform to the Office of the Architect for the University’s Exterior Lighting Study and the UVA Office of the Architect for the University’s Landscape Typologies and Standards, linked at the OUBO website (<https://oubo.virginia.edu/udg.html>).

Site lighting poles and fixtures will be Owner Furnished and Owner Installed (OFOI). The Owner, Power and Light will provide pole and light fixture and will make final connections. The Contractor shall provide necessary conduit and shall stub out of the building to a handhole box, and shall provide the contactor, controller photocell and wiring to the handhole. Handholes must be HS-20 or Tier 22 traffic rated, minimum. The Owner will install all conduit, wiring, foundations and poles and fixtures beyond the handhole. The Contractor shall coordinate with Owner for notification as to the schedule. All other lighting, such as building mounted, patio, courtyard, handrail and exterior steps and bollard light fixtures, shall be Contractor Furnished and Contractor Installed (CFCI); Approval by Power and Light and the Office of the Architect is required for all Contractor Furnished site lighting. The Owner will not install these fixtures. Concrete pole bases that are near vehicular traffic shall be not less than 36” tall or other acceptable height in consultation with Power and Light.

4.12.1.4 LIGHT FIXTURES AND SPECIAL REQUIREMENTS FOR OFF-GROUNDS FACILITIES

See Appendix A Figure 6 for Edgewater fixture for major pathways.

Lamp wattage and IES distribution type to be determined by layout.

Note: Manufacturer make/model/options change without notice. Please contact UVA FM Power and Light team for latest fixture make/model.

4.12.1.5 INSTALLATION REQUIREMENTS

Site lighting fixtures are to be powered with underground copper wiring in 1-1/4" PVC conduit. Burial depth shall be 18" minimum. Site lighting shall be photocell controlled in logical groups. Individual unit photocell controls are to be used only where grouping of lights is not practical.

All pole and post-mounted lighting fixtures shall be numbered on the construction documents and on the erected fixture. Fixture ID number and label size/style can be obtained from Geospatial Engineering Services or Power and Light.

4.12.2 SERVICE AND DISTRIBUTION

4.12.2.1 POWER

New buildings or services shall be connected to the University's distribution system. Where existing buildings or services are connected directly to Dominion Energy, renovation and addition projects shall convert these services to the University's distribution system. The utility transformer will be owned by either FM-Power and Light or Dominion Energy depending on the power provider.

For all new services, relocations, switchgear upgrades, utility data requests (for coordination or arc-flash study), drop service (shutdowns) and any other associated work at all Dominion Energy direct-drop buildings, please contact Power and Light. Any work that will involve working with Dominion Energy must be planned and coordinated. Please include Power and Light during project design and planning conversations. On Dominion Energy services, all secondary conductors from the transformer, CT cabinets, and meters that are the property of Dominion Energy shall not be demolished without their permission and any new secondary conductors, CT cabinet and meter will be provided by Dominion Energy. All installation must conform to Dominion Energy's Blue Book, latest edition.

4.12.2.2 MEDIUM-VOLTAGE TRANSFORMERS AND PRIMARY SWITCHES

All new or replacement transformers shall be rated for primary voltage of 12,470V for North Grounds substation service or 13,200V for Cavalier and Alderman substation services. Copper or aluminum windings may be used for outdoor liquid filled primary transformers. All other dry type transformers shall have copper windings. Primary taps shall be sized for 600A conductors. Architect/ Engineer can request a certain transformer size however, the transformer sizing will be determined by Power and Light. All medium voltage cabling, transformer and switches will be procured by Power and Light and will be billed to the project.

Internal tank fuse links or fuses are prohibited. All primary overload protection shall be external to the transformer. All buildings shall be fed with two primary feeders, where dual primary feeders are available. Transformers serviced with dual feeder configuration shall have a separate external fused 15 KV selector switch. The basis of design for primary pad-mounted switches shall be S&C PMH type, either PMH-6, PMH-9 or S&C Vista 321.

1. Exterior transformers shall be pad mounted, liquid-filled type with the following:
 1. Dead front with 200 amp load-break bushing well inserts
 2. Temperature rise of 65°C
 3. Outside Air cooled
 4. Where exterior pad-mounted transformer and/or switches are used, Facilities Management in consultation with the Office of the Architect for the University shall approve their locations.
2. Interior transformers shall be dry-type with the following:
 1. Temperature rise of 115°C maximum
 2. High Voltage Basic Impulse Level of 95 kV
 3. A cast primary and either a vacuum pressure impregnated (VPI) or cast secondary is preferred
 4. Ambient Air cooled with at least the provisions for Forced Air cooling.
As an alternative, a silicone or other less-flammable liquid-filled transformer (as defined by NEC 450.23) may be used indoors. The liquid shall be Factory Mutual approved.
Transformer characteristics shall be the same as for exterior liquid-filled transformers.

Electrical services for research, medical and other critical facilities shall be designed utilizing a double-ended transformer configuration with a secondary tiebreaker. They shall be designed with auto-tie operation. Dual transformers shall be designed to permit replacement of either unit without disturbing the other transformer.

4.12.2.3 DISTRIBUTION

4.12.2.3.1 PRIMARY CABLE

1. Shall be copper, single conductor cable, listed for 15 kV service.
2. Type MV-105, insulated to 133% insulation level, 220 mils. EPR is preferred.
3. All cable shall be suitable for use in wet or dry locations.
4. Shielding may be either a copper tape shield or corrugated drain wire system.
5. Cable shall be identified by phase markings on the outer jacket at intervals not to exceed 2'.
6. Cable shall be installed in concrete encased underground duct banks and electrical vaults. Direct burial of primary cable (>600V) is not allowed.
7. Primary cables run between electrical vaults shall be either 500 or 750 kcmil, depending upon the UVA primary feeders involved. Cables from the last electrical vault to the primary switch may be smaller and are typically 2/0 copper.
8. 15kV cables shall be tested at 22kV (DC) for 30 minutes (minimum)

4.12.2.3.2 TERMINATIONS

1. All electrical vault medium voltage cable splices shall be made with re-connectable modular splice kits that meet ANSI/IEEE Standard 386.
2. In electrical vaults and other accessible enclosures, wrap individual primary cables separately with fire retardant tape.

4.12.2.3.3 DUCTBANKS

1. Shall be a continuous concrete structure with reinforcing, #4 bars (minimum 2 bars)
2. longitudinal at 1 bar per 48" width of duct bank at bottom with minimum 3" cover.
3. Shall use 6" Schedule 40 PVC conduit for runs between electrical vaults. Duct banks runs

from last electrical vault to primary switch may use 5" conduits.

4. Top of duct bank shall be a minimum of 24" below finished grade.
5. Shall slope to drain to prevent accumulation of water in the duct bank and shall not have any low points.
6. A utility marker tape shall be buried 12" above each duct bank.
7. A mandrel shall be pulled through all duct banks prior to cable installation.
8. Concrete for duct banks and electrical vaults shall have a minimum compressive strength of 3,000 psi at 28 days, meeting requirements of ACI 318 and ACI 301.

4.12.2.3.4 ELECTRICAL VAULTS

Refer to Electrical Vault Detail in Appendix A (Figure 14)

1. At change of direction for main electrical line
2. At intervals not exceeding 300' in a straight run.
3. Minimum of 8' x 8' x 6'-6" (interior dimensions).
4. Minimum 3'-0" diameter frame and cover opening for access from outside.
5. The manhole be designed waterproof with engineered joints using with coal tar bitumen, asphaltic sealant, O-rings or gaskets and watertight boot-pipe connections and that the structure pass watertightness testing. Manhole shall be dampproof with proper treatment of the concrete surface to retard the absorption of water or penetration of water vapor.
6. Covers in paved areas shall be sealed.
7. Shall have 18" x 18" x 12" deep corner sump. Floor to slope gently to sump. Sump shall be drained through percolation (improved if required with stone filled pit) or through a drainpipe sloped to daylight with the end protected against rodent entry.
8. The light switch and fan switch shall be 20 amp, 120 volt devices with covers in a rain tight device box mounted near the electrical vault opening for easy access from outside.
9. A ground rod shall be provided at each electrical vault. Ground rod penetration shall be watertight.
10. Precast electrical vaults shall not have more than two sections. The joint between sections shall be sealed watertight.
11. All construction including cover shall be HS 20 traffic rated.
12. Refer to Standard UVA Vault Ladder detail in Appendix A (Figure 13).
13. Electric vaults do not require ladder or light.

4.12.2.3.5 SERVICE CONDUCTORS

Service conductors from transformer to building shall be concrete encased. Reinforcing shall be provided for large and/or lengthy runs. Where multiple taps are made at the service transformer, each of the feeder shall have overcurrent protection at the nearest point of entry.

4.12.2.4 TESTING REQUIREMENTS

All electrical systems shall be tested prior to acceptance. All testing shall be in accordance with the International Electrical Testing Association (NETA) Acceptance Testing Specifications, manufacturer's recommendations or other approved testing standards. An independent testing company shall perform testing. Contractor shall notify the testing agency when the systems are ready for testing.

Copies of test reports and any recommendations shall be furnished to the Project Manager. Power and Light shall be notified in advance of testing.

4.12.3 EV CHARGING STATIONS

Chargers made by Enphase, ChargePoint, or Blink are recommended. Chargers powered from building electrical panel shall be sub-metered. Chargers installed in garages may not need a sub- meter.

Chapter 5 Building Envelope

The building envelope shall incorporate materials and detailing consistent with a building life span of not less than 50 years, with optimized energy management and environmental sensitivity.

Proposed changes to a building exterior, including new exterior mechanical systems, shall receive pre-approval from the Office of the Architect prior to OUBO review.

5.1 CONCRETE

Minimum concrete strength shall be 3,000 PSI. Exposed aggregate shall not be used for exterior surfaces due to freeze-thaw.

Wet curing is required. Use of a curing compound must be approved and is limited to instances where application of moisture is impractical; where application of such compounds will not jeopardize appearance of concrete or bond to additional concrete; and where concrete surface is to be finished with paint, tiles, waterproofing, roofing or chemical seal.

5.1.1 ARCHITECTURAL CONCRETE

The Contractor shall provide a sample panel for exterior exposed concrete walls prior to construction showing all finishes, texture of formed material, sandblasting, etc. Concrete used in sample panels shall be provided from the project concrete supplier and shall represent the approved mix for strength and texture.

5.1.2 CAST IN PLACE CONCRETE

Specifications shall include the following requirements:

1. ACI 301, Specifications for Structural Concrete shall be incorporated by reference.
2. Field tests of fresh concrete shall include ASTM C172 (Sampling), ASTM C143 (Slump), ASTM C31 (Specimens), ASTM 231 or ASTM C173 (Air Content), and ASTM C138 (Density).
3. The University shall engage the Services of the concrete testing laboratory to perform the sampling, cylinder preparation and delivery, testing and reporting. The Contractor shall be responsible for adequate advance Notice to the testing laboratory for the Contractor's concrete pours/placement.

5.1.3 FIBER REINFORCED CONCRETE

Use of fibrillated polypropylene fiber for secondary reinforcement to control surface cracking in exposed concrete slabs on grade is encouraged. However, fibrillated polypropylene fiber is not a substitute for reinforcing for structural and expansion/contraction requirements.

5.1.4 POST TENSIONED STRUCTURAL CONCRETE

The A/E shall give special consideration to the finished appearance of jacking-ends, insert requirements, and tendons and reinforcing steel cover of post-tensioned structural members.

5.1.5 SLAB ON GRADE

Slab on grade floors in all academic, public use and service buildings; and public use, mechanical, laundry and storage rooms in residential/dormitory buildings; shall be minimum 5" thick with WWF 6x6- W2.9xW2.9 reinforcing. Slab on grade floors in residential/dormitory buildings, other than rooms noted above, shall be minimum 4" thick with WWF 6x6- W1.4xW1.4 reinforcing. Reinforcing top cover shall be 1" minimum to 2" maximum.

5.2 SUPERSTRUCTURE

5.2.1 GEOTECHNICAL DESIGN AND EARTH PRESSURE LATERAL LOADS

Building framing shall be designed to resist Earth Pressure Lateral Loads internally. In situations of unbalanced Earth Pressure Lateral Loads against a building/structure, calculations shall be performed to verify Global stability of excavation at critical stages of construction, whether excavation support systems are used or not, and for the completed building/structure condition after final grading.

5.2.2 STRUCTURAL COMPATIBILITY WITH EQUIPMENT: VIBRATION, MAGNETICS, ELECTRICAL SENSITIVITY

Structural framing for research laboratories and other uses with sensitive instrumentation shall be designed to resist vibration. The Basis of Design Narrative shall note the vibration criteria used to develop structural calculations and construction details.

Research and medical facility structures intended to house magnetically and electrically sensitive equipment must be designed using compatible structural materials and techniques.

5.2.3 ADDITION OF LOADS TO EXISTING STRUCTURES

Prior to mounting any antennae, microwave dishes, HVAC equipment or other items on the roof of an existing building, the adequacy of the structural framing to support the additional live, dead, wind lateral loads, vibration, and overturning moments at attachments shall be checked by a licensed Structural Engineer. Rooftop additions as described above are subject to approval by the Office of the Architect and the AARB.

5.2.4 SPRAY FIREPROOFING DESIGN AND SPECIFICATION

A spray fireproofing submittal – including drawings with typical and unique details – shall clearly show and coordinate locations, ratings, and the specific fireproofing products used.

The Office of the University Building Official may require submission of shop drawings for review, depending on extent of SFRM scope and documentation provided during the design phase reviews.

At the intersection of structural steel members with different thicknesses of spray fireproofing, provide spray fireproofing equal to the greater thickness on all members for a distance of 2' minimum from the intersection of the members.

Spray fireproofing shall meet or exceed the fire rating on all clips, hangers, light gauge framing, support sleeves and other attachments covered at the area of attachment to a structural member.

5.3 EXTERIOR ENCLOSURE

5.3.1 EXTERIOR WALLS

Masonry veneer exterior walls may use either concrete masonry unit (CMU), metal-stud framing, or other approved materials for veneer backup. Exterior envelopes using materials other than CMU require submittal of the following:

1. An approved hygrothermal analysis based on ASHRAE 160 indicating satisfactory performance with respect to condensation management and relative humidity
2. Stainless steel anchorage
3. 18-gauge (minimum) studs

5.3.1.1 MOISTURE PROOFING

University buildings shall not be designed with basement floor levels below the water table. The following criteria shall be met for other conditions:

1. Soils with little or no obvious water content:
 - a. Waterproof walls and provide protection board.
 - b. Provide perforated type drainage pipe with gravel surrounding.
 - c. Backfill with suitable material that has some porosity.
2. Damp to wet soils with no obvious water source:
 - a. Waterproof walls and provide protection board. If geotechnical type drainboard is used, protection board may not be required.
 - b. Provide perforated drainage pipe and, if necessary, surround with full height gravel to the underside of the impervious soil or material.
 - c. Provide impervious soil or material at finish grade.

5.3.1.2 BRICK SELECTION

During the Preliminary Design phase, the A/E shall obtain approval from the Office of the Architect for the University (OAU) for brick, mortar and joint tooling.

Wood mould brick shall be used on most University buildings. Wire cut brick shall in general be used for all University of Virginia College at Wise projects. Removal of existing brick for use on additions or renovations shall be carefully executed to prevent cracks, splits, spalls and damage to the surface integrity of the units.

Additions to existing buildings shall match the existing brick in size, color, texture and compressive strength. If new brick and/or mortar are to match an existing pattern, the specifications shall identify the wall area of roughly 100 bricks to be matched. Mortars with color pigments shall be premixed.

The specifications shall require the contractor to erect one or more wall panels (4'-0" x 4'-0" minimum) of the selected bricks, mortar, masonry backup, wall ties, insulation and limestone/precast stone trim, etc. The A/E and the OAU will approve the panel for workmanship and conformance with the approved selection of brick and mortar.

5.3.1.3 WALL DETAILS

Parapets: All parapet walls up to 3'-0" height above roofing shall be flashed from coping to roofing.

Masonry Thresholds: Brick or stone thresholds in conjunction with metal thresholds shall rest entirely on the building foundation walls.

Coatings: Water repellent coatings on above-grade masonry shall not be used.

Masonry Accessories: Water stops shall be built-in rubber type. Dovetail slots and anchors shall be used for masonry veneer over concrete walls. Weep holes shall be rope wicks spaced no more than 16" on center, or open head joint weeps with metal, mesh or plastic screens, spaced no more than 24" on center.

Cladding and Siding: Metal clad buildings shall be used only for utility type structures not located on the Historic Grounds, Central Grounds or in view from publicly traveled streets and walkways, unless approved by the OAU. Wood siding is an acceptable material only in ancillary areas such as dormers.

Flashing: All through wall flashing shall be 16-oz. minimum copper or equivalent fabric-coated copper. Stainless steel through wall flashing may be used with prior approval of the OAU. If stainless steel flashing is used, it shall be Type 304 Stainless Steel meeting the requirements of ASTM A666, and shall be a minimum of 0.018 in. (0.4572 mm) thick. Other metals or vinyl flashing shall not be used. All coping flashing shall be through wall type.

Sealants, Caulking and Seals: The color and appearance of sealants and caulk are to be approved by the OAU as part of the overall design review. Caulk or sealant joints should be 3/4" maximum width. If a joint is requested to be wider, then an appropriate finish material/cover should be installed.

Portland Cement Plaster: Portland cement plaster stucco, with or without aggregate, may be used for base and finish coats over masonry, roughened monolithic concrete and metal lath. It shall not be used over wood lath, fiberboard lath, gypsum lath, gypsum tile or other types of base coat.

5.3.2 EXTERIOR PAINT

A color schedule for all exterior materials shall be submitted for approval by the Office of the Architect for the University.

Paint removal by open flame shall not be permitted. Where paint is removed by a heating process, a fire extinguisher must be available at the work site.

5.3.3 EXTERIOR WINDOWS

Metal windows and storefront shall have thermal break frames and insulating glass. For all buildings, the use of double-glazing is required, with a vacuum seal and low E glass.

Aside from the required use on the Historic Grounds, the use of wood windows must be approved by the Office of the Architect for the University and the Director of Facilities, Planning and Construction.

Crank operators shall not be used on operable windows. If an interior mounted storm sash is provided, it shall be hinged or otherwise readily accessible for window maintenance.

5.3.4 EXTERIOR DOORS

All main entrance doors along accessible routes shall be equipped with automated door operators. The location of wall-mounted, door operator push buttons shall be coordinated with the Office of University Building Official. Use of floor/mat activators is prohibited. See 1.4.3 Security.

Plastic laminate finish on exterior doors is prohibited.

5.3.4.1 METAL DOORS/FRAMES

Metal doors shall be insulated. Hollow metal doors shall have 16-gauge facing skins, be galvanized, and be one and 1 3/4" thick minimum. Knockdown frames are prohibited.

5.3.4.2 WOOD DOORS

Solid core wood doors shall be five ply, 1 3/4" thick minimum. Paneled wood doors shall be detailed and manufactured to withstand weather exposure. Use of paneled style door is restricted to the Historic Grounds when pre-approved by the Office of the Architect for the University.

5.4 ROOFING

5.4.1 GENERAL

1. Consultation with the University Roofing Project Manager is mandatory for all projects with new roofing as well as reroofing projects.
2. All roof assemblies shall be constructed as VUSBC Class A.
3. Calculations are required for all projects that include roofing and shall be provided on the drawings:
 - a. Roof drainage system calculations for primary and secondary drain capacity and sizing.
 - b. Wind uplift design pressures calculations.
4. Plans shall include basic roof information separated into discernable sections, each including: square feet area, roof type, slope directions, insulation thickness and type (when used), elevation, and deck type.
5. Where warranted by manufacturers, fasteners into concrete and masonry shall be of a type that can be easily removed without damage during future roof replacements.
6. Consultation with the University Roofing Project Manager is mandatory at the conclusion of roofing and shall include presentation of:
 - a. Roofing contractor's guarantee.
 - b. Manufacturer's warranty.
 - c. Manufacturer's certification that roofing materials used comply with specified ASTM standards.
 - d. Final roofing survey report.
 - e. Form DGS-30-328 History of Roofing.

5.4.2 LOW-SLOPE ROOFS AND ACCEPTABLE ROOFING SYSTEMS

5.4.2.1 WARRANTY

1. All low-slope roofs shall obtain primary and secondary roofing and insulation materials from the roof system manufacturer to ensure a single-source responsibility for entire roofing system.
2. Manufacturer's total system warranty period shall be fifteen years; all detailing will be designed and specified to meet thirty-year warranty requirements.
3. Roofing contractor's guarantee period shall be two years.

5.4.2.2 ROOF SLOPE

1. Specify that all saddles and crickets shall have a slope twice that of the roof field.
2. Specify that all valleys shall slope a minimum of 1/8" per foot.

5.4.2.3 WIND UPLIFT

1. Complete roof assemblies shall comply with ANSI/SPRI WD-1 and ASCE 7.

5.4.2.4 INSULATION

1. Polyisocyanurate board insulation shall be used and have a nominal average compressible strength of 25 psi. When a high-density top layer with minimum ½" thickness is provided, then 20 psi insulation is acceptable.
2. Board insulation shall be installed with a minimum of two layers per manufacturer's installation instructions. Fit boards together with no gaps and stagger joints in both directions to achieve a complete thermal envelope.
3. The following items require preapproval by the University Roofing Project Manager: CFC (chlorinated fluorocarbons) insulation blowing agent, phenolic foam insulation and organic fiberboard insulation (including use as tapered edges).
4. Mechanical fasteners for post-tensioned concrete decks or pre-stressed concrete panels require preapproval by the University Roofing Project Manager.
5. Pull tests shall be provided for all mechanically fastened systems.

5.4.2.5 ACCEPTABLE LOW SLOPE ROOFING SYSTEMS

Solar Reflective Membranes: New low-slope roofing projects shall utilize materials that meet a three-year aged SRI value of 64. If three-year aged value information is not available, use materials that meet an initial SRI value of 82. The membrane specified shall contain KEE HP or have a KEE molecular weight of greater than 50%. The roof must be protected from discoloration during construction, washed, and left clean at the completion of work. TPO roofs are not permitted on Academic Division Buildings.

Single-Ply Membrane (SPM): Acceptable systems include:

1. Single-ply, fully-adhered, reinforced black EPDM membrane, 60-mil thickness.
2. Single-ply, fully-adhered, non-reinforced black EPDM membrane, 60-mil thickness, with high-density cover board.
3. Single-ply, fully-adhered, non-reinforced black EPDM membrane, 90-mil thickness.

The University Roofing Project Manager and CC&R Facilities Associate Director must approve single-ply membrane roof systems that do not match these standards.

Built-Up Roof (BUR): A hybrid BUR is acceptable for heating plants and similar facilities where documented preapproval is provided by the University Roofing Project Manager. The acceptable system is a 3-ply asphalt built-up roof with a granule-surfaced modified bitumen cap sheet having a minimum cap sheet thickness of 150 mils.

5.4.3 STEEP-SLOPE ROOFS AND ACCEPTABLE ROOFING SYSTEMS

5.4.3.1 GENERAL REQUIREMENTS

1. 60 mil, self-adhesive polymer-modified bituminous sheet ice and water barrier with slip resistant mineral granule surface shall extend continuously: from outer edges of eaves and gutters to 30" minimum beyond the line of the exterior wall below, 30" from rake edges and roof penetrations, and 36" to both sides of valleys. Use #30 un-perforated asphalt saturated roofing felt.
2. Closed valleys are prohibited. Exceptions may be applicable for historic structures.

5.4.3.2 ACCEPTABLE STEEP-SLOPE ROOFING SYSTEMS

1. Slate
 - a. Slate from Arvonja, Buckingham County, Virginia.
 - b. Specify genuine unfading blue-black slate, ASTM C406, Grade S-1, of size, thickness, texture, exposure style, shape and color to match existing. All slate shall be hard, dense, sound, and rock punched for two nails.
 - c. No cracked slate shall be used. No broken corners on covered ends shall be allowed. All exposed corners shall be partially full. Slate used at the University is typically 3/8" thick nominally, with face dimensions of 10" wide by 16" long. No corner break shall exceed 1/2" in either dimension. Slates shall have the following physical properties:
 - d. Modulus of rupture: 9,000 psi per ASTM C120
 - e. Water absorption rate: 0.25% per ASTM C121
 - f. Depth of softening/acid resistance: 0.001 inches per ASTM C217
 - g. New slate roofs shall be installed over 3/4" tongue and groove, solid lumber decking. Use of plywood as a nailing deck is prohibited.
 - h. Copper nails are to be used to hang slate.
 - i. When ice and water barrier is used as an underlayment for slate, it shall be rated for high temperature.
2. Metal
 - a. Terne-coated stainless steel; field-formed double-lock standing-seam
 - b. Terne-coated copper; field-formed double-lock standing-seam
 - c. Copper; field-formed double-lock standing-seam
 - d. Aluminum or steel; architectural standing seam manufactured roof panel system, PVDF finish
3. Shingles (other than slate)
 - a. Use of wood shingles or shakes is prohibited, except for in-kind replacement of existing roofing.
 - b. Three-tab fiberglass or dimensional shingles may be used with preapproval from the Office of the University Architect.
 - c. Minimum warranty accepted for asphalt shingles is thirty years; lifetime warranty is preferred.

5.4.4 ROOFTOP-MOUNTED PHOTOVOLTAIC SYSTEMS

1. Coordinate with the UVA Office for Sustainability to determine the feasibility of solar photovoltaic installations on all low-slope roofs.
2. The following guidelines shall be followed for PV installations:
 - a. NRCA Guidelines for Rooftop-Mounted Photovoltaic Systems.
 - b. Single Ply Roofing Industry (SPRI) Technical Bulletin 1-13.
 - c. Roof system manufacturer's requirements.

5.4.5 VEGETATED/TERRACE ROOFS AND ACCEPTABLE ROOFING SYSTEMS

See the Office of the Architect for the University's Vegetated Roof Standards for additional requirements and the Department of Environmental Quality Design Specifications for vegetated roofs in the latest Virginia Stormwater Management Handbook for additional requirements. Submit vegetated roof plans to the Standards and Specifications Administrator for compliance review.

5.4.6 UNACCEPTABLE ROOFING SYSTEMS

The following roofing systems are not permitted for use at the University unless preapproved by the University Roofing Project manager:

1. Ballasted single-ply membranes
 - a. Where accepted, minimum requirements include 10-12 pounds of ballast per square foot, double-washed, rounded, and smooth river gravel, with a diameter not to exceed 1½”.
 - b. Ballasted systems are prohibited on any UVA Health facility.
2. Mechanically fastened single-ply membranes
3. Sprayed-on polyurethane foam
4. Modified bitumen systems, except the Built-Up Roofing system noted in Section 5.4.2.5.
5. Cold applied roof systems
6. Any roof systems that are torch applied
7. Protected roof membrane (PMR) systems, also referred to as inverted roof membrane assemblies (IRMA), except as noted in Section 5.4.5.
8. Application of a new roofing system over an existing system; roof-over or re-cover

5.4.7 STEEL ROOF DECK

1. Corrosion protection is critical to maintain the structural integrity of the roof deck from moisture leaks through the roofing membrane. NRCA Bulletin 15-91 provides guidance on protection.
2. The steel roof deck is required to be Factory Galvanized, G-60 or G-90 (ASTM A924-94) or Factory coating with aluminum zinc alloy (ASTM A792).
3. ‘Primer paint’ coated deck is not permitted.

5.4.8 BLOCKING AND MISCELLANEOUS CARPENTRY

1. Oriented strand board (OSB) or particleboard shall be permitted only with specific approval by the University Roofing Project Manager.
2. All panel materials shall be rated for exterior use. Wood blocking to be untreated southern yellow pine, except where required by code to be fire retardant treated lumber.
3. Power-driven screw-type fasteners shall be used to fasten wood to wood, or wood to masonry.

5.5 ROOF DRAINAGE, EQUIPMENT, AND ACCESSORIES

5.5.1 GENERAL

1. New roofs and major renovations must have access via an enclosed stairway. In renovations, ladder or hatchway access is acceptable only if stairway is impractical. Means for safe access to all adjacent roof levels shall be provided from the main roof.
2. Ladders 24 feet and higher shall not use safety cages as a means of protecting workers. New vertical ladders and/or alterations to existing ladders require a ladder safety system or personal fall arrest system.
3. All buildings shall have a positive means of conducting rainwater from the roof to a stormwater management practice, cistern, or the storm sewer system.
4. When an entire flat roof system is being replaced on a roof and there are no secondary (emergency) roof drains or scuppers, secondary drainage shall be provided as part of the re-roofing project.
5. Metal flashing, counter flashing, cleats, clips, drip edges, exposed metal trim/ridge cap, cant

strips, scuppers, eyebrow roof vents, and exposed metal valleys shall be one the following materials:

- a. Terne-coated stainless steel
 - b. Terne-coated copper
 - c. Copper
6. Continuous cleats are required.
 7. Built-in reglets shall be provided for new wall-flashing terminations. Surface applied reglets shall only be provided on existing buildings where installation of built-in reglets is not possible. To facilitate future roof replacements or recoveries two-piece counter flashings shall be provided at terminations.
 8. Solder all non-expansion joints in metal work. Avoid lap joints where possible.

5.5.2 ATTACHED GUTTERS

1. On sloped roofs, adequately sized and securely installed gutters of minimum 16-gauge metal shall be specified. Stainless steel or PVDF-coated steel may be used on additions to existing buildings with similar existing gutters and may be used on new buildings where the context does not heavily reference traditional style and/or materials. A minimum slope of 1/16-inch per foot for gutters is required. A minimum of two downspouts for each drain area shall be provided.
2. Gutter spikes are not allowed.

5.5.3 BUILT-IN GUTTERS

Built-in gutters are only permitted with an approved D&F. Where approved the following shall apply:

1. Built-in metal gutter liner shall be terne-coated stainless steel, terne-coated copper, or copper.
2. Lap joints are not permitted.
3. Expansion joints are required.

5.5.4 DOWNSPOUTS

1. Downspouts shall be a minimum of 16-gauge, shall be adequately sized and securely fastened to the vertical plane, and shall empty into a cast iron boot at grade connected to a storm water management practice, cistern or the storm sewer system. For existing facilities where this is not possible, water will be directed away from the building and new splash blocks will be provided.
2. Where a building is located near trees, down leader protective baskets shall be provided to keep leaves from entering drain inlets in gutters.

5.5.5 SNOW GUARDS

1. Snow guards are required for all roofs with a slope of 6 in 12 or greater and over all entrances regardless of slope.
2. On slate roofs and historic hand-formed standing-seam roofs a minimum of three staggered rows of guards are required. Snow guards shall be butterfly type: copper, stainless steel, or bronze.
3. Wire snow guards are not acceptable.
4. On new/modern standing-seam metal roofs, use metal snow rail systems that are attached to the standing seams. Butterfly type snow guards mounted on top of the standing seams are not acceptable.

5.5.6 ROOFTOP SAFETY

1. OSHA approved fall protection shall be provided for 100% coverage on all new and replacement roofs and considered in the following order:
 - a. Elimination of Hazard: Remove maintained equipment from the roof, provide a 39" to 42" minimum height barrier (e.g. parapet, railing); provide an equipment screen; or keep necessary equipment and drains away from roof edge.
 - b. Protection by Fall Restraint
 - c. Protection by Fall Arrest
2. Consultation with the University Roofing Project Manager and Facilities Management's Office of Health and Safety is required for all fall protection designs.
3. When UVA FM maintenance have specified/required that exterior elements are to be maintained or cleaned by suspension methods (such as boatswain's chair, rope descent, or temporary scaffolding), then designs shall incorporate support systems (anchors, davits, outriggers, etc.) which allow access to the building elements to be maintained.

5.5.7 ROOFTOP EQUIPMENT

1. Rooftop mounted equipment (excluding fume hood exhausts, power roof ventilators, and similar equipment functionally required on the roof) is discouraged. Rooftop equipment in new construction is subject to approval by the Office of the Architect for the University and must be screened from view of other buildings, streets and walkways.
2. Abandoned equipment shall be removed and the decking repaired on re-roofing projects.
3. Where new rooftop equipment or repair/replacement of existing rooftop equipment is approved, the project must incorporate the following:
 - a. Provide adequate space and appropriate lighting for access and maintenance of the equipment. Elevated equipment must have permanently installed ladders and platforms to all equipment access panels and items requiring ongoing maintenance.
 - b. Provide durable walk pads from roof access point to and around all rooftop equipment. Walk pads must be at least 2' wide and extend 6' from the equipment on the sides requiring service accessibility.
 - c. Provide 12" clearance under rooftop equipment and horizontal supporting members to finished roof (24" clearance if the equipment is > 24" wide). Supports shall be mounted and fastened to structural deck or framing, not insulation.
 - d. Use of wood sleepers for rooftop equipment is prohibited.
 - e. Equipment curbs shall not be placed in drainage valleys. Crickets shall be installed on upslope sides of equipment curbs.

5.5.8 ROOF HATCHES

1. Where roof hatches are utilized, they shall be insulated, lockable, and feature thermal breaks.
2. Design of roof hatches shall meet OSHA standard for fall protection. Fall protection measures including but not limited to: top of ladder extension devices, safety railing systems, tie-off anchors, and orientation that enables opening the hatch without turning around.

5.5.9 SKYLIGHT STRUCTURES AND CLERESTORY WINDOWS

1. The use of skylight structures, unit skylights and clerestory windows shall be approved as part of the Schematic or Preliminary Design process by the Office of the Architect of the University.
2. Design of skylights and roof replacements at existing skylights shall meet OSHA standards for fall protection.

3. Drawings and specifications for skylights or clerestory windows shall indicate dimensioning, flashing, sealants, gaskets, joints and other quality criteria intended to prevent leaks and minimize maintenance. All skylights shall have a minimum 5" high curb on sloped roofs; 12" on flat roofs.

Chapter 6 Interiors

6.1 DESIGN AND FINISH CRITERIA

Building entrances, lobbies and significant public areas are within the purview of the Building & Grounds Committee, and as such, require design input and approval by the Office of the Architect for the University (OAU). The OAU is responsible for the design of building interiors, including furniture, fixtures, equipment and systems (FF&E) – approval shall be coordinated by the Project Manager.

As a public university, extravagant and higher maintenance finishes are discouraged. Interior finishes shall be selected from manufacturer's standard material selection; custom material selections are prohibited. Materials, equipment, and specifications shall be written in a non-proprietary manner (see HECOM Chapter 8).

See additional finish requirements in Chapter 8: Green Building Standards.

6.2 PARTITIONS

6.2.1 GENERAL

Metal stud or masonry partitions shall be used for all non-bearing partitions. Metal stud minimum thickness for non-bearing partitions shall be 20-gauge-Drywall (minimum thickness 0.0296 in), 16" on center. Bearing partitions shall be 20-gauge-Structural or heavier depending on loading and shall be designed in accordance with AISI S100.

Accordion folding partitions are prohibited.

6.2.2 FIRE RATED ASSEMBLIES AND FIRE STOPPING

Fire rated assembly details, with approved independent testing agency numbers, shall be indicated on architectural drawings for Preliminary Design and Construction Documents. The A/E shall incorporate into specifications the requirement that the contractor shall notify the owner's representative of non-compliant or omitted fire stopping encountered during construction. Specifications shall include requirements for closing all openings in fire-rated assemblies at the close of work each day.

Hilti is the suggested provider at UVA Health facilities.

Fire rated penetrations and joint assemblies shall be marked with a label identifying:

1. "WARNING. FIRE RATED PENETRATION OR JOINT ASSEMBLY. DO NOT DISTURB. NOTIFY BUILDING MANAGEMENT OF ANY DAMAGE."
2. The fire rated design number from a listing agency
3. The hourly rating
4. The manufacturer of the fire rated materials
5. The specific product used
6. The installer's name and company

6.2.3 OPEN OFFICE PARTITIONS

The University utilizes established contracts for the design, purchase and installation of open office partitions and associated components. The A/E shall review the vendor's drawings and specifications

for coordination and interface with electrical systems and incorporate the system design into the contract documents.

6.2.4 GLAZING

ALL interior glazing within 7' of the finish floor, sidelights, and frameless glass doors shall be safety glazing and shall have markings complying with current New York City Building Code Section 2410 Marking of Transparent Doors & Fixed Adjacent Transparent Sidelights (see the OUBO website, <https://oubo.virginia.edu/udg.html>). Minimum opacity of any marking lower than 66" above finish floor to be 50%. Design of required marking requires OUBO pre-approval. D&Fs are not permitted.

6.3 INTERIOR DOORS

6.3.1 GENERAL

Doors shall have a minimum width of 3'-0" and minimum height of 7'-0". Wood doors shall be five plies, solid core with a minimum thickness of 1¾", and a lifetime warranty. Metal doorframes shall be welded construction. Clear glazed vision panels shall be used in all classroom and stair doors. Doors with a full glass lite shall have a minimum 5½" vertical stile to accept UVA standard operating hardware.

The following door types are not accepted: folding doors, pocket doors, hollow core wood doors, and plastic laminated doors. Dutch doors are prohibited in UVA Health.

6.3.2 MISCELLANEOUS DOOR HARDWARE

Doors wider than 3'-0" or which have closers shall have ball bearing hinges or full length, continuous style hinges. Door closers shall be of the heavy-duty cast iron type with a minimum 10-year warranty. Aluminum bodies are prohibited. Closers shall be mounted to doors with through-bolts. Floor pivot hinges, floor closers and concealed overhead closers are prohibited.

Wall-mounted doorknob bumpers shall be backed by intermediate steel plates or channel reinforcement. Floor stops are prohibited. Doors subject to abuse by equipment associated with building function shall have kick plates as well as guards to prevent damage to door or hardware.

In UVA Health buildings, low-energy door operators shall be Horton 4100LE, and power-assisted door operators are not permitted.

6.3.3 LOCKSETS AND ACCESS CONTROL

See Appendix F.

6.4 INTERIOR SPECIALTIES

6.4.1 FIRE EXTINGUISHERS

Fire Extinguisher Cabinets in existing UVA Health buildings shall be identified consistent with existing cabinets. Cabinets in new UVA Health buildings shall meet the current NFPA 10 requirements for identification of fire extinguisher locations. A wall mounted blue light shall be installed above all fire extinguisher cabinets in the Hospital.

6.4.2 BUILDING SIGNAGE

Signage shall be provided by contract or by UVA Facilities Management Creative Services as directed by the Project Manager. Signage in UVA Health buildings shall comply with the UVA Health Interior Wayfinding and Signage Standards Manual. Signage in all other buildings shall comply with the University of Virginia Signage & Wayfinding Guidelines (available on the Office of the Architect website or linked from the OUBO website, <https://oubo.virginia.edu/udg.html>) and must be coordinated through Facilities Management's Creative Services team.

For all capital projects, the UVA PM shall submit a sign package to OUBO for approval prior to installation of signs. The package shall consist of floor plans identifying the following:

1. Locations of all code and UDG required signs, using the sign ID nomenclature from the applicable UVA sign standard
2. Location and proposed language for required wall mounted directories at main entrance lobbies (where existing directories are not adaptable)
3. Locations of required directional signage at main entrance lobbies identifying the location of the elevator and accessible toilets (if those elements are not readily visible in the lobby). Directional signs shall comply with ICC A117.1 703.2 Visual characters, 703.3 Raised characters and 703.4 Braille.

6.4.3 TOILET AND BATH ACCESSORIES

The A/E in consultation with the Project Manager shall consider the established practices of Facilities Operations, Health System Physical Plant or Student Housing Division when placing accessories. For Academic Projects, UVA PM to consult with Custodial Services Superintendent.

UVA Health installations shall have infrared controls that are hard-wired, with battery backup, on all hand washing sinks in public areas and paddle blades on sinks in clinical areas.

Ensure all accessories are provided/shown on plans and elevations, including:

1. The University provides Toilet Paper Dispensers, Paper Towel Dispenses, Soap Dispensers, Sanitary Napkin Disposals, and in some locations, Sanitary Napkin Dispensers. These appliances are to be Owner Furnished, Contractor Installed (OFICI). PM to coordinate with Custodial Services for the number and location of these dispensers and disposal.
2. Not less than one soap dispenser per two lavatories in each restroom. Countertop mounted soap dispensers are prohibited.
3. A 3" minimum width metal shelf above all lavatories not mounted in a countertop. Shelf shall be finished to match adjacent accessory trim and approximately 18" in length. The shelf may be integral with the mirror.
4. Mirrors shall include a minimum ten-year warranty against silver spoilage.
5. Free-standing waste receptacles with a minimum capacity of 32 gallons in all toilets having more than one lavatory.
6. Academic project water closets should be equipped with commercial grade, solid plastic seats that are resistant to chips, wears, and stains.

6.4.4 TOILET PARTITIONS

Powder coated steel, ASTM A424, Type I, commercial quality overhead braced toilet partitions are required. Stainless steel finishes are prohibited. Alternative materials (plastic laminate, marble and high-density polymer resin) are to be approved through the Project Manager prior to the submission of the Preliminary Design for review. Exposed particleboard or wood toilet partitions are prohibited.

6.4.5 WALL AND CORNER GUARDS

Wall and corner guards are required in corridors and other areas where service carts, moveable equipment, hospital patient stretchers or beds and similar equipment will be used.

6.4.6 CHALKBOARDS

Use chalkboards of laminated porcelain/ceramic enamel coated steel face material. Slate chalkboards are prohibited in UVA Health.

All chalkboards will have trim of aluminum or wood, full width chalk trays, and tack strip with map rails as an integral part of the chalkboard assembly head trim in all classrooms. Map rail combo hook/clips are suggested for each board supplied. Include accessories for map rail use. A 50-year warranty or better is recommended for classroom chalkboards. Chalkboard color of black is recommended in classroom application.

6.4.7 CUBICLE CURTAINS

UVA Health may utilize separate contract(s) for purchasing cubicle curtains. The A/E must incorporate the products from the selected vendor(s) into the project design and determine, with the Project Manager, the responsibilities of the contractor to be incorporated in the construction documents.

6.4.8 DRINKING FOUNTAIN WITH BOTTLE FILL STATION

In new construction and major renovation projects, provide at least one drinking fountain with an integrated water bottle fill station on each floor. Station shall be located in a public area of the building.

6.4.9 PUBLIC ACCESS AUTOMATED EXTERNAL DEFIBRILLATORS (AED)

All new buildings and major renovation projects shall include AEDs, AED cabinets and AED signs in locations determined by the Office of Emergency Management. The AEDs, AED cabinets, and AED signs vendor and model are determined by the Office of Emergency Management. AEDs will be semi or fully recessed cabinets to prevent them from being protruding objects. Coordinate the locations of the AEDs with the Office of Emergency Management at aed@virginia.edu.

6.5 INTERIOR FINISHES

Agency 209 (UVA Health) projects shall comply with the approved University Hospital (UVA Health) Finishes List, based on type of occupancy (Hospital, Ambulatory Care Clinic, Business/Admin). Deviation from the approved Finish List requires written pre-approval.

6.5.1 WALL FINISHES

The minimum single layer thickness of gypsum wallboard shall be 5/8" for walls.

6.5.1.1 PAINT SELECTION AND COLOR

Paint finishes shall be satin, except for UVA Health, which shall be eggshell. Trim finish shall be semi-gloss. Other paint finishes may be acceptable with approval through the Project Manager. Paint selections are to be made during the design process. Health System paint colors shall be approved by UVA Health Facilities Planning and Capital Development.

6.5.1.2 WALL COVERINGS

Wall coverings with textures capable of harboring dirt and/or organic contamination are prohibited in patient care facilities.

Specify 5% quantities in whole rolls of wall covering materials for each project in which they are used. Additional materials are to be turned over to the Construction Administration Manager.

Vinyl coated wall coverings shall be medium weight (14 to 20 oz. per square yard) in areas with average traffic (offices, reception areas, hospital rooms and dining rooms) and heavy weight (24 to 32 oz. per square yard) for areas where there is heavy traffic or wear (corridors, classrooms, gymnasiums and service areas).

6.5.2 FLOOR FINISHES

6.5.2.1 CONCRETE FLOORS

All exposed concrete floors shall be sealed.

6.5.2.2 CERAMIC AND QUARRY TILE

Ceramic tile floor and base shall be used in restrooms and showers with non-slip floor surfacing. Cement backer board shall be used in all metal stud partition systems. Detailing shall minimize moisture penetration. Quarry tile floor and base shall be used in laundries and food preparation areas and shall have integral non-ferrous non-slip surfacing.

6.5.2.3 HARDWOOD FLOORING

Hardwood flooring, excluding athletic flooring, requires Facilities Management approval coordinated by the Project Manager. Weather protected entrances shall be installed to prevent water damage. When approved for use over a concrete slab, a moisture barrier is required. Wood flooring is not allowed in patient care areas.

6.5.2.4 RESILIENT FLOORING

Resilient tile flooring shall be homogeneous solid composition with minimum 1/8" thickness. Specify American Biltrite Texas Granite 24"x24" vinyl composition tile for Health System projects. Specify 12"x12" tile for all other projects.

6.5.2.5 RESILIENT BASE

The standard resilient base in University facilities is a heavy-duty vinyl or rubber base with a minimum thickness of 0.125" and a minimum height of 4". For areas subject to heavy-wheeled equipment traffic or frequent maintenance buffing equipment, the minimum height shall 6". Outside corners shall be specified as premolded.

6.5.2.6 CARPET

The use of separate padding under carpet is prohibited except when authorized by Facilities Management. Carpet in UVA Health is prohibited in all clinical areas.

6.5.3 CEILING FINISHES

6.5.3.1 GENERAL

Access to all utilities above the ceiling shall be provided regardless of ceiling type used. Access panels shall be shown on the contract documents. The A/E shall provide clear requirements in the plans and specifications for the proper reinforcement and support of lighting fixtures and access panels in finished ceilings.

6.5.3.2 SUSPENDED ACOUSTICAL TILE

When using acoustical tile systems in alterations, they should match any existing tiles in the area. Armstrong is the suggested provider in UVA Health. Large interlocking tiles require prior written approval.

Chapter 7 Building Services

7.1 BUILDING SERVICES GENERAL

7.1.1 INTRODUCTION

Heating ventilation and air conditioning (HVAC) equipment, electrical systems, elevator systems and building equipment shall be as energy efficient as possible. EPA ENERGY STAR equipment shall be provided whenever available.

University buildings shall be designed for at least a 40-year life with minimum life cycle cost rather than low first cost. See UVA Life Cycle Cost Calculator (Chapter 8: Green Building Standards) for details and standard inputs. All building components should be new and the most current model with readily available replacement parts for the expected life of each item.

All mechanical and plumbing equipment that require maintenance shall be readily and safely accessible. Where equipment, valves, and components that require maintenance are installed above a ceiling, they shall be installed as low as practical.

During renovations all plumbing/mechanical pipe, equipment, and associated components that are being taken out of service shall be removed. Pipe and equipment can only be abandoned in place where removal would require cutting into the building structure.

Ethylene Glycol shall not be used except where provided with proprietary local cooling systems; Propylene Glycol is acceptable where freeze protection is needed. When glycol heating, cooling or fire protection systems are fully or partially drained, all glycol shall be recovered. Glycol systems shall be configured and signage provided to prevent any amount of glycol from being discharged into the storm or sanitary drain systems except for an emergency discharge of a glycol fire protection system. The full procedure on glycol management is available at the website for UVA Environmental Resources Standard Operating Procedures to Prevent Pollution or linked on the OUBO website (<https://oubo.virginia.edu/udg.html>).

For systems serving a building area greater than a renovation project area, or affecting other occupied facilities, specifications shall require that Facilities Operations (Health System Physical Plant for UVA Health) be notified through the Construction Administration Manager using the Veocci outage system not less than ten working days before such systems may be affected.

Spaces designated as unfinished in new construction shall have plumbing, HVAC and electrical utilities stubbed into them so that when they are finished in the future no demolition is required in the space and outside of it to provide utilities.

All building systems with IT networking capabilities (wired, WiFi, cellular, Bluetooth, Zigbee, etc) except for pre-approved Building Automation Systems and card reader systems, must receive approval from FM Technology and Innovation (fm-ti-systems@virginia.edu). FM-T&I will act as a point of contact for a committee representing appropriate stakeholders. Example building systems include lighting, elevator, and electrical systems with one or more IP-addressed components.

7.1.2 REVENUE METERS FOR UTILITIES

All utilities in all buildings shall be metered and shall be connected to the metering SCADA network, Schneider Electric Power Monitoring Expert.

All meters (unless otherwise stated), shall be owner furnished and contractor installed and shall be installed and operational prior to connection of utilities. Electric meters shall be provided by the contractor and integral to the main electric switchgear. The operation and calibration of all meters shall be verified and corrected, if necessary, within ten working days of connection to utilities.

See also 7.3.1.2 Domestic Hot Water; 7.4.2.3 Meters, Gauges, Indicators and Thermostats; 7.6.1.4 Electricity Metering; and 7.7 Electronic Monitoring and Controls.

7.1.3 SUBMETERING

The following guidelines outline when building submetering shall be installed.

7.1.3.1 TENANT SUBMETERING

All main utilities (domestic water, domestic hot water, building chilled water, building hot water, electricity) serving a non-UVA tenant (i.e., food service) shall be metered in accordance with this section.

7.1.3.2 DOMESTIC WATER SUBMETERING

Provide a separate revenue grade flow meter for irrigation systems, boiler, chiller and cooling tower make-up and blow down. Flow meters shall be owner furnished and contractor installed (OFCI). Flow meter shall be installed on the domestic cold water make-up line, where applicable.

7.1.3.3 DOMESTIC HOT WATER SUBMETERING

Provide a non-revenue grade flow meter for domestic and service hot water uses connected to water heaters greater than 20,000 Btu (or 6 kW). Flow meters shall be owner furnished and contractor installed (OFCI). Flow meter shall be installed on the domestic cold water make-up line.

7.1.3.4 CHILLED WATER SUBMETERING

Provide a non-revenue grade flow meter for chilled beam supply and process chilled water uses. Provide a meter at all process chilled water heat exchangers. Flow meters shall be OFCI.

7.1.3.5 RECLAIMED WATER SUBMETERING

Provide a non-revenue grade flow meter for all reclaimed water installations. Flow meters shall be OFCI.

7.1.3.6 ELECTRICAL SUBMETERING

Where a project requires additional electrical submetering beyond building-level metering, electrical submeters shall be contractor furnished and contractor installed (CFCI).

See also 7.3.1.2 Domestic Water; 7.4.2.3 Meters, Gauges, Indicators and Thermostats; 7.6.1.4 Electricity Metering; 7.7 Electronic Monitoring and Controls; and Appendix B.

7.1.4 AESTHETIC CONCERNS

Repairs and modifications to existing concealed mechanical, plumbing, electrical and utility equipment shall remain concealed, both on the interior and exterior of buildings.

7.1.5 SOUND PRESSURE LEVEL REQUIREMENTS

Sound pressure levels around exterior mechanical and electrical equipment shall not exceed the limits set forth in the City of Charlottesville or Albemarle County Noise Ordinance, or the dBA/time limitations set forth in the Occupational Noise Exposure/Hearing Conservation Amendment latest edition.

7.1.6 OPERATIONS AND MAINTENANCE MANUALS

See 1.5.4 Spare Parts and Maintenance Materials.

7.1.7 COMMISSIONING

All new and replacement mechanical, plumbing, electrical and envelope systems shall be commissioned per the requirements in LEED, ASHRAE Guideline-0, and procedures as directed by the Project Manager. Requirements in those standards for testing after one year in service shall be included. In addition, all fire and smoke dampers shall be tested for operability after one year in service.

Specifications shall stipulate that until commissioning and BAS Closeout Process are satisfactorily completed, no heating, ventilation and air conditioning system will be accepted by the University. The warranty period on all equipment will begin only after acceptance by the University.

See Chapter 8: Green Building Standards for additional commissioning requirements.

7.1.8 TRAINING AND DEMONSTRATION OF SYSTEMS

After commissioning is complete, but prior to beneficial occupancy or substantial completion, the contractor shall provide field training for designated Facilities Management personnel who are responsible for the operation and maintenance of HVAC, building automation system, electrical, emergency safety equipment, fire protection/detection equipment and systems and stormwater management practices. Classroom training can be held prior to commissioning. Field training shall include a demonstration of all required maintenance activities and proper operation of all control sequences. Dedicated training shall be provided on equipment or systems that are new technologies or new to the University. The A/E shall schedule all training and demonstration activities no less than two weeks in advance.

Training shall cover the use and maintenance of specialty diagnostic tools and specialty diagnostic tools shall be provided to the owner. For compliance with UVA's Federal Title V Permit, a written record of training shall be generated that includes the names of trainees, the date of training and the nature of the training. This requirement applies to emergency generators, other fuel burning equipment, and other sources of air pollution. A copy of the training records shall be provided to Environmental Resources.

7.2 ELEVATORS

The A/E is encouraged to consult with the Elevator Maintenance Supervisor by arrangement with the Project Manager. Recommendations may include proven manufacturers to be included in specifications. Cab door heights over 8'-0" shall be prohibited unless approved by the Operations Department. Additional specification requirements are noted in Appendix C: Elevators.

7.3 PLUMBING

7.3.1 DOMESTIC WATER

7.3.1.1 WATER SUPPLY AND TREATMENT

Domestic water is obtained from the University distribution system. New service lines shall be valved at the point of connection to the main and at entry to the building. The use of domestic water for process cooling is prohibited. Note in specifications that water lines shall be disinfected and tested for bacteria at the completion of project.

Discharges of water from disinfection and bacteria testing shall follow UVA's Dechlorination Standard Operating Procedures to Prevent Pollution (SOP) as appropriate. The full procedure is available at the website for UVA Environmental Resources, Standard Operating Procedures to Prevent Pollution, or linked on the OUBO website (<https://oubo.virginia.edu/udg.html>).

Pressure reducing valves (PRV) shall be provided in all buildings at the domestic water entrance just downstream of the meter. On the domestic water service entrance provide a strainer, meter with bypass loop, PRV with bypass loop, and then two parallel full size back flow preventers. Isolation valves shall be installed so that either BFP can be removed. Back flow preventers shall be mounted a maximum of 5'-0" above the floor and shall be readily accessible for maintenance.

Vacuum breakers used for mop sinks and food service shall be pressure type in accordance with ASSE 1020.

See 4.4 Exterior Domestic and Fire Service Water Piping for requirements also applicable to exterior domestic water piping.

7.3.1.2 DOMESTIC HOT WATER

One hundred-and forty-degree Fahrenheit domestic hot water is produced in the Hospital Building. Contact Facilities Management Energy and Utilities or UVA Health Physical Plant for specific locations served. Any necessary water heaters used in Health System buildings shall be double wall.

Where available, water from one of the University's heating water loops shall be used to generate domestic hot water. Domestic hot water should be generated (and stored if needed) at 140° F minimum. The ASSE-1017 compliant master mixing valve shall be a digital type. UVA Health facilities shall be provided with a BACnet integrated, monitored mixing valve. The connection to the heating hot water system shall be upstream of the building heating water blending system. See Appendix A Figure 11B for the current plant supply and return water temperatures and seasonal reset schedules. However, the University's long-term goal is to reduce the heating water distribution temperature to 130° F, so adequate space and connections shall be provided for a future electric topping heater.

Tankless or localized point of use electric water heaters shall be used for small loads. Water heaters shall not be installed above ceilings.

Chemical sterilization and/or booster heater systems must be used for dishwashing needs instead

of higher temperature supply hot water.

7.3.2 MATERIALS AND SYSTEMS

All domestic water piping inside buildings shall be copper or stainless steel. Copper shall be type L hard drawn with soldered joints, however mechanical joints may be used on domestic cold water and domestic hot water up to 190° downstream of the PRV. Mechanically extracted tees shall not be used. Stainless steel pipe with welded joints can be used on larger size domestic water where more economical than copper. Supports and other metal parts subject to wear use shall be galvanized. All fittings shall be at least Class 150.

Shut off valves are required at the main service entrance into buildings, on each floor, on take-offs from all vertical risers, on branch lines from the mains and at the connection to each piece of equipment.

Domestic water pipe shall not be installed in or under concrete slabs on grade, except where necessitated by building entrances or under sidewalks. Pipe sleeves shall extend 2" above the floor to serve as a dam in any area where flooding is possible due to nearby plumbing fixtures or mechanical equipment.

Faucets shall contain all mechanical parts "above deck" (i.e., inside the faucet head). Faucets, flush valves, and other materials shall not require an 'app' or remote to program and/or operate.

See Chapter 8: Green Building Standards for water fixture requirements. See also 6.4.8 Drinking Fountain with Bottle Fill Station.

All piping systems shall be hydrostatically tested after installation. The test pressure shall be 150 PSI or 1 ½ times the working pressure, whichever is greater. Components not suitable for a 150 psig test may be tested at a lower pressure and then valved off for the 150 psig test. New or modified branches can be tested at system pressure. Test duration on pipe with soldered joints shall be at least two hours; the test duration on pipe with mechanical joints shall be 24 hours.

7.3.3 IDENTIFICATION

All piping and equipment in mechanical equipment rooms and central plants shall be completely colored according to the "Scheme for the Identification of Piping Systems," ANSI A13.1 and the "Safety Code Color for Marking Physical Hazards," ANSI Z53.1, refer to Appendix A Figure 16.

All piping in buildings shall be identified by means of alphabetical stencils and color codes, showing contents of the piping and the direction of flow. Piping shall be identified at 30'-0" intervals, on both sides of penetrations through walls and floors, and at each directional change.

All valves shall also be identified with stamped brass tags or discs secured with non-ferrous beaded chain. Valve numbers shall be engraved or stamped as large as possible on tags (1" x 2") or discs (1.25" diameter) attached to the valves by 10-gauge brass "S" hooks. Provide a framed valve schedule in mechanical rooms.

7.3.4 WATER DISTRIBUTION

Note the following details when preparing plans and specifications:

1. Insulation on domestic water lines shall be continuous through floors, walls and studs.
2. Closed water piping systems shall have air vents to purge any trapped air.
3. Valves shall be compatible with piping materials. Non-ferrous full port ball valves up to 4" can be used on domestic water. Non-ferrous or ductile iron butterfly valves can be used on 2 ½"

and above. Gate valves shall not be used except where provided with backflow prevention devices.

4. Drain valves shall be installed in accessible locations at all low points in the piping system to permit drainage and servicing.
5. Dielectric fittings shall not be used and 6" long brass nipples shall be used when connecting piping of dissimilar metals.
6. When plumbing fixtures are removed but not replaced, domestic water pipes shall be removed to within five pipe diameters of the main to prevent leaving a long dead leg, and terminated with a capped ball valve. Where plumbing fixtures are removed but the water pipes will be reused the pipes shall be capped to prevent debris from entering pipes.
7. Aerators shall not be used in any patient care areas or hospital areas where they would create a legionella risk.
8. No ultra low flow fixtures shall be provided in UVA Health facilities.
9. Hose bibs shall be spaced at a maximum of 100' around the entire building.
10. On demand water heaters designed for low flow fixtures shall be installed where appropriate.

7.3.5 STORM AND SANITARY WASTE SYSTEMS

Sanitary cleanouts shall be located with a minimum floor clearance of 15" from adjoining walls or built-in features, such as toilet stalls or casework. Unless approved as an exception for servicing vertical risers, cleanouts shall not be located in vertical surfaces. Where wall cleanouts are allowed, the access shall be within 1" of the wall. Also provide cleanouts on sanitary and storm lines on exterior lines within 5' of the building.

All storm lines shall be continuous from the inlet to a stormwater management practice, cistern, or the storm system outside the building; high level drains and drains from sloped roofs shall not discharge onto lower roofs unless needed for a Green Roof or LEED credit. The construction manager and contractor shall inform UVA's Standards and Specifications Manager prior to installing stormwater management practices (BMPs) so they may be inspected.

Pumped discharge lines from sewage and storm ejectors shall not be combined with gravity drains inside buildings. Pumped and gravity drains shall run separately to the nearest manhole.

All gravity storm and sanitary drains shall be cast iron except for an acid resistant material where justified and for under slab and footing drains. All sanitary piping above grade in the hospital shall be fused plastic piping, similar to polyolefin (not PVC or CPVC). Pumped storm and sanitary lines shall be copper; type L inside the building and type K outside. Footing drains exterior to the building shall be schedule 40 PVC or cast iron. Foundation drains, storm drains under the slab, and sanitary drains under the slab can be Schedule 40 PVC.

7.3.6 PIPING SYSTEMS FOR GASES

Natural gas is available from the Gas Division of the Charlottesville Department of Public Works for distribution and shall be coordinated through the Energy & Utilities Department. Natural Gas piping systems within buildings shall be black steel. Outside distribution piping shall be approved plastic. The A/E must verify the capacity of lines serving the area in which work is to be done.

Piped gas systems shall be thoroughly identified and coded and all fuel gas pipe downstream of the meter shall be above grade. Natural gas outlets shall not be installed in bio-safety cabinets or other contained rooms or areas that are not fully exhausted. Natural gas shut-off valves shall be provided at the entrance to the room in which the gas is being used. Unions shall be provided downstream of tees. Close nipples and shoulder nipples shall not be used on natural gas systems.

Piping of any gases in UVA Health (Hospital and Medical School) projects will require special coordination with UVA Health Physical Plant. All medical gas outlets shall be D.I.S.S. type. All piping, tubing and fittings shall be pre-cleaned. Copper shall be type K.

Vacuum pumps shall be CLAW, variable speed, oil lubricated or dry rotary vane type; liquid ring vacuum pumps shall not be used.

Air compressors shall be variable speed.

7.3.7 EMERGENCY SHOWER AND EYEWASH EQUIPMENT

Emergency eyewash and shower stations are required in areas where chemical, biological, radiological or physical hazards exist that may expose the eyes or body to corrosive, infectious or other injurious materials. These hazards and spaces include labs with and without fume hoods, human immunodeficiency virus/hepatitis B (HIV/HBV), hazardous drugs, caustics, battery charging stations, chemical treatment for hydronic systems, surgical suites, vivarium, art studios and maker lab spaces. The location of emergency irrigation equipment shall be made upon consultation with OEHS and will adhere to applicable regulations and consensus guidelines (e.g. The National Research Council's/Prudent Practices for Handling Hazardous Chemicals in Laboratories/National Academy Press, most recent edition). Locations shall be in the same room as the hazard, within 50 feet in the path of travel and no more than 10 seconds of walking time from the hazard. The specifications and installation of emergency irrigation equipment shall comply with the latest version of ANSI Standard Z358.1. Tempering valves are required and should be set to discharge 85°F. All spaces where Biosafety Level 2 or Animal Biosafety Level 2 (housing) and above materials are manipulated require a permanently installed eyewash and a hand wash sink.

Safety showers should be highly visible and identified with signs or decals. Showers with pull down bars are preferred over chain pulls. Provide floor drains below emergency showers.

ANSI-approved eyewash facilities shall be provided in at least one sink in each laboratory or work area (i.e., shop areas, mechanical rooms, etc.) if substances used there are known to present a potential eye hazard. The project team should work with OEHS and the customer to ensure that sink functions that will occur in the laboratory do not obscure the presence of the eyewash fountain or obstruct access.

Provide a combination emergency eyewash & drench hose unit [not an emergency shower], with an ASSE 1071 tempering valve set to 85°F, in all custodial closets.

7.4 HEATING, VENTILATION, AND AIR CONDITIONING

7.4.1 DESIGN PARAMETERS

7.4.1.1 ENERGY PERFORMANCE

See Chapter 8: Green Building Standards for energy performance requirements.

7.4.1.2 DESIGN CONDITIONS

See Appendix A Figures 11 and 11a for inside and outside design criteria.

For any Occupancy/Use not shown in the Inside Design Condition Criteria (Appendix A Figure 11) consult ASHRAE Handbooks or other applicable references for suggested criteria and obtain CFO approval of conditions proposed for use in design.

7.4.1.3 CONTROLS AND SYSTEMS

1. Mount supply and return fan VFDs close enough together so the readouts can be seen at the same time without moving.
2. Constant volume systems shall only be used where required by program or where variable volume air control is impractical. Constant volume recirculating systems shall have a means to pre-cool and dehumidify outside air before being mixed with the return air rather than cooling the entire supply airstream to dehumidify and then reheating. A chilled water coil, heat recovery device or other method approved by Facilities Management may be used.
3. Individual offices shall have means of ensuring acceptable temperature control (user adjustable thermostat and control device, appropriate zoning or other designed means). Where air terminal devices serve multiple offices provide a temperature sensor in each office, averaged to control the air terminal device. Individual offices shall have a means to sense occupancy that is integrated into the building automation system per Section 7.7.1.1 (e.g., occupancy sensor- integrated thermostat, lighting occupancy sensor integration).
4. Untempered outside air shall not be supplied directly to occupied spaces or into the returns of fan coil units.
5. AHU coils shall have a minimum of eight (8) inches clearance between them and other components, front and back, to facilitate field installation of BAS sensors.
6. In UVA Health facilities, AHUs serving critical/regulated spaces shall be provided with double block and control bypass valving configurations on all coil connections.

7.4.1.4 IDENTIFICATION

1. Piping and equipment in mechanical equipment rooms and central plants shall be completely colored according to the "Scheme for the Identification of Piping Systems", ANSI A13.1 and the "Safety Code Color for Marking Physical Hazards," ANSI Z53.1, refer to Appendix A Figure 16. Piping in buildings shall be identified by means of alphabetical stencils and color codes, showing contents of the piping and the direction of flow. Piping and duct shall be identified at 20-foot intervals, on both sides of penetrations through walls and floors, and at each directional change.
2. Valves shall be identified with valve numbers engraved or stamped as large as possible on brass tags (1" x 2") or brass discs (1.25" diameter) attached to the valves by 10-gauge brass "S" hooks. Provide a framed valve schedule in mechanical rooms.
3. Motor driven equipment, HVAC components and major electrical boxes shall be individually numbered on the drawings by the A/E and have corresponding number plates on the equipment. (Example: For unit heaters, use UH-1, UH-2, etc., even though both units are of the same size and type.) All designations shall be integrated with and distinguished from existing designations.
4. The construction documents shall require the contractor to color identify all equipment using the numbering system shown on the drawings with a color that contrasts with the equipment finish. In finished areas, identification shall be located on the inside surfaces of access doors; in unfinished areas, identification shall be located on outside surfaces. Gravographic plastic or comparable plastic tags shall be used and permanently attached at both the equipment and the disconnect/VFD.
5. New equipment containing 50 pounds or more of refrigerant should have a nameplate attached which identifies the manufacturer, model and serial numbers, date of

manufacture, type of refrigerant, and maximum quantity (full charge) of refrigerant in the system.

7.4.2 CHEMICAL CLEANING AND CHEMICAL WATER TREATMENT OF BOILERS AND HVAC SYSTEMS

1. The boilers, the HVAC systems, all system piping, and all system related equipment shall be thoroughly flushed per the manufacturer's instructions. Steel pipe shall be flushed with appropriate cleaning chemicals.
2. In individual buildings, only closed loop systems, such as secondary heating water and process water, shall have chemical treatment (chemical treatment for fluids from central systems will be provided at the heating or chiller plant).
3. The contractor is responsible for providing all equipment, fittings, tubes, valves, connections, labor, chemicals, and miscellaneous hardware for the boiler boil-out, for the flushing, cleaning and associated water treatment and for the initial chemical water treatment for the boilers and HVAC systems.
4. The University provides chemicals to be used for the initial treatment of the system after flushing and cleaning have been completed.
5. The A/E must specify that the contractor notify the University approximately thirty days before the boil-out/cleaning of the system and the application of the chemicals are started. The University's Water Treatment Consultant shall observe and monitor the boil-out/cleaning of the system and the initial charge of chemicals required for placing the equipment in normal service.
6. The Construction Documents shall require that after cleaning and chemically treating boilers and HVAC systems, the contractor shall furnish the University, in writing, the following information:
 - a. Date of initial treatment.
 - b. Type of chemical(s) used for treatment.
 - c. Estimated date that further treatment or testing will be required.

7.4.2.1 DISTRIBUTION

1. Taps shall be provided to measure flow rate (GPM) at each pump and at each heat exchanger; however, circuit setters shall not be used. Wells for thermometers shall be provided before and after each heat exchanger.
2. Hydronic pipe shall not be installed in or under concrete slabs on grade, except where necessitated by building entrances or under sidewalks.
3. Shut off valves are required at the main service entrance into buildings and on each floor at takeoffs from all vertical risers. Full port ball valves can be used on pipe up to 4"; butterfly valves can be used on pipe 2-1/2" and larger. Gate valves shall not be used. All air handler coils, reheat coils, convectors and fan coil units shall incorporate isolation valves.
4. Strainers shall be provided at the inlet to all pumps and loads. All strainers shall be provided with blow down valves (use ball valves). Blow down lines shall be extended so the valve and valve handle are clear of the pipe insulation. The outlet shall be clear of adjacent pipe and other obstructions.
5. Hydronic pipe shall be steel or Type L hard drawn copper. Joints shall be soldered, brazed, threaded, welded, or flanged. Mechanical joints can be used on services 190° F and below.

Mechanically extracted tees shall not be used. All fittings shall be Class 150 or higher. Flexible connectors can be used on terminal heating and cooling devices (they shall not be kinked).

6. 6" long (between threads) brass nipples shall be used when joining dissimilar metals. Dielectric fittings, unions, and flanges shall not be used.

7.4.2.2 TESTING AND BALANCING

1. All HVAC systems shall be tested and balanced in accordance with a standard of a recognized testing laboratory.
2. All piping shall be tested at 150 PSI or 1.5 times the design pressure, whichever is greater. Test duration shall be at least two hours; where mechanical joints (such as Pro-Press) are allowed, the hydro test shall be held for 24 hours. Pressure tests shall be witnessed by the Energy and Utilities Department System Manager, the Maintenance Superintendent, or their designees.
3. All welds in high pressure steam, pumped condensate and MTHW piping shall be x-rayed. The x-rays of the welds shall satisfy ASME B-31.1.
4. In steam PRV stations, the pipe up to the shut off valves downstream of the first stage PRV's shall be pressure tested and x-rayed per the requirements of HPS.
5. Testing and balancing of building chilled and hot water distribution pumps shall use the revenue meters and not the DP across pumps. A portable meter with less than 1% error shall be used on branches that do not have full flow; a suitable meter can be borrowed from the University if available.

7.4.2.3 METERS, GAUGES, INDICATORS AND THERMOSTATS

All incoming utilities in all buildings shall be metered and shall be connected to the University's electric power monitoring (SCADA) system. See 7.7.1 Application.

1. See Appendix B: Utility Metering Requirements.
2. Gauges shall be specified on supply/return of pumps, chillers, converters and where lines enter and exit mechanical rooms.
3. Thermometers shall be specified on supply/return water chillers, air-handling units, fan coil units and at other points.
4. Gauges for general use shall have screw-type recalibration, bronze bushed movements and single unit construction.
 - a. In main mechanical rooms, provide 4.5" diameter gauges for all steam pressures, and mounted a maximum of 8'-0" above the operating floor.
 - b. Gauges shall be calibrated for static head.
 - c. All gauges shall be non-pulsating.
 - d. Pipe taps for gauges shall be between the 3 and 9 o'clock positions.
 - e. Isolation valves for gauges shall be ball valves rather than gauge cocks.
5. Temperature gauges are acceptable where mercury thermometers would be difficult to read.
6. Gauges and thermometers shall read to twice the operating pressure or temperature.

7.4.3 MECHANICAL LOCATION AND EQUIPMENT

See 5.5.7 Rooftop Equipment and 7.4.5.1 Sources/Outside Air.

7.4.3.1 MECHANICAL ROOMS

The A/E shall, in the earliest stages of design development, be responsible for establishing and/or verifying programmatic requirements for mechanical rooms in order to provide for replacing the largest piece of equipment without removing permanent walls or large items of equipment or equipment essential to the ongoing day to day building use. In phased projects, mechanical rooms shall be sized to include equipment for all the phases.

Concrete floors in mechanical rooms shall be sealed.

7.4.3.2 FIRE SEPARATION OF EQUIPMENT

Direct fired heating equipment and make-up air heating equipment shall be separated from other air handling equipment by a one-hour fire-resistance rated wall except for combination heating and cooling equipment.

Buildings with critical loads as identified by the Energy and Utilities Department or HSPP shall have external taps for the connection of a portable boiler and/or chiller.

Attic spaces may be used for air handling equipment; however, compressors, condensers and distribution pumps shall not be located in attics. Attic access shall be from interior stairs (or elevator where practical), which shall be large enough and suitable for replacement of the largest component of the mechanical equipment. Attic mechanical spaces shall be equipped with space for storage of mechanical drawings, maintenance manuals, filters, etc. Floor moisture detectors shall be tied to University's Systems Control Center and all AHUs in attics shall have protection so a large leak will not flood floors below.

7.4.3.3 EQUIPMENT

All coils, pumps, fan coil units, VAV boxes, terminal heat transfer units, control valves and other devices requiring service shall have adequate isolation valves and unions or flanges to allow replacement without a total system drain down. Unions shall be provided on both sides of every automatic control valve. Shut off valves on chilled water, heating hot water, steam, condensate, and glycol shall be ball or butterfly. Butterfly valves 6" and larger shall have gear operators. All sizes of valves installed higher than 7'-0" shall have chain drives. Triple duty valves are acceptable on constant volume pumps but are not acceptable on variable volume pumps.

All air handler units shall be provided with a single point of electrical hook up when appropriate to size or type. All other air handlers shall show all circuits and voltages necessary for fans, lights, etc.

Floor mounted pumps shall have suction diffusers.

Flexible pipe joints shall be braided stainless steel rather than rubber.

Cogged V-belts shall be specified for constant speed motors, HTD type belts shall be specified for motors with VFDs.

Pipe sleeves shall extend 2" above the floor to serve as a dam in all areas where plumbing fixtures or mechanical equipment present a possibility of flooding.

7.4.3.4 VIBRATION AND SOUND ISOLATION REQUIREMENTS

Mechanical and electrical equipment, associated piping and ductwork shall be mounted on vibration isolators to minimize transmission of vibration and noise to the building structure or spaces. All motors over five horsepower must be solidly attached to a base common with the driven

unit to minimize alignment problems. Solid sheaves and band belts shall be used to minimize vibration in multiple V-belt driven equipment. All rotating equipment shall be balanced, both statically and dynamically. The structure supporting the equipment shall not have any natural frequencies within +/- 20% of the normal operating speeds. The equipment, while operating, shall not exceed a self-excited radial vibration velocity of 0.10" per second or an axial vibration velocity of 0.05" per second when measured with a vibration meter. Vibration test pickups shall be placed on bearing caps in the horizontal, vertical, and axial directions or on equipment mounting feet if the bearing caps are concealed.

Walls and floors enclosing mechanical rooms adjacent to occupied spaces shall have a sound attenuation factor of 10 decibels or greater, above the determined or probable airborne noise level of the operating equipment. In no such applications shall the rating be less than a 55-decibel STC (Sound Transmission Class).

7.4.4 HEATING

7.4.4.1 SOURCES

1. Heating Hot Water: Refer to Chapter 4: Energy and Utilities.
2. Steam: In many buildings in the Central Grounds, steam is available. Refer to Chapter 3 for additional details. High Pressure and Medium Pressure steam systems shall be dropped to low pressure steam using pressure staging and pressure reducing valve stations. Each pressure reducing valve station shall have a 1/3 and 2/3 capacity PRV and a bypass. The MPS and LPS headers shall have pressure relief valves vented to atmosphere through the roof. All uncontaminated steam condensate, including condensate from clean steam humidification systems must be returned to the system. All drip condensate from humidifiers shall be returned to the building condensate system. Steam from the central plant shall not be used directly for winter humidification. Plant steam or MTHW may be used to make clean steam for humidification. Water softener and automatic blow down are required. Clean steam generators shall be shut down in the summer.
3. Electric heating: Electric heating sources shall be considered the preferred method in areas where University-provided hot water is not available. Heat pump type systems shall be used for space heating/cooling and centralized domestic water heating applications. Electric resistance heating is permissible for cooking and point-of-use water heating applications. The use of electric resistance as the primary source of heat is not allowed.
4. Natural Gas: The use of natural gas in buildings shall be limited to applications where cost-effective electric heating alternatives are not available. Natural gas shall not be used for new space or water heating installations within buildings. Consideration for future electrical infrastructure shall be considered to enable electrification of gas equipment prior to the University's target date of eliminating on-site combustion by 2050.

7.4.4.2 MATERIALS AND EQUIPMENT

7.4.4.2.1 HEAT EXCHANGERS

All steam to LTHW converters shall have 90/10 copper/nickel tubes and brass tube sheets. Provide thermometers (or temperature gauges) on all legs of water-to-water heat exchangers, and on both fluid legs of steam converters. Provide elbows on the header connections to facilitate tube removal. Vent lines from pressure relief lines shall be run to the nearest floor drain and anchored at the end.

All fired or unfired pressure vessels whether a part of an equipment package or an entire piece of equipment shall be specified to comply with the ASME Code. The specifications shall require that the pressure vessel be so stamped in an easily identifiable location and that the manufacturer's data indicating ASME compliance be submitted. Comply with the Boiler and Pressure Vessel Rules and Regulations issued by DLI.

7.4.4.2.2 INSULATION

Insulation on high-pressure steam, pumped condensate, and MTHW in mechanical rooms shall be fiberglass rated for 800°F or calcium silicate with a glued canvas jacket. Insulation on pre-insulated direct-buried MTHW lines shall be rated for at least 300°F. The minimum insulation thickness on HPS and MTHW shall be 4" on pipe 6" and above and 3" on pipe 4" and smaller. Removable insulation blankets with double D-rings and straps shall be provided on all steam, condensate and hot water valves and fittings that cannot be properly fitted with fiberglass or calcium silicate insulation. Insulation used in walls, ducts, and piping shall not have added formaldehyde.

7.4.4.2.3 MISCELLANEOUS HEATING COMPONENTS

1. All duct reheat coils shall have access doors or panels to allow inspection and cleaning of coil inlet.
2. All fittings on secondary hot water systems shall be class 150 or better.
3. Humidifiers shall have insulated dispersion tubes. The outlets of dispersion tubes shall be oriented per the manufacturer's instructions.

7.4.4.2.4 BOILERS

1. All new and replacement oil fired boilers that exceed 1 MMBTU/HR and gas-fired boilers that exceed 10 MMBTU/HR fuel input require an air permit from DEQ prior to ordering the equipment. Coordinate permit requirements with UVA Environmental Resources through the Project Manager.
2. Environmental Resources shall be notified of any removal, replacement, or new installation of boilers of any size.
3. All gas and fuel oil burners shall be low NOX.

7.4.4.3 BUILDING DISTRIBUTION AND CONTROLS

Fan coil units, perimeter radiators, preheat coils, reheat coils and all other heating in occupied spaces shall use secondary heating water from a blending system located in the building served by the University heating water distribution system. These secondary heating water systems shall be designed as part of a 4-pipe system rather than dual temperature systems.

In inpatient buildings and other critical buildings as specified provide valves and capped tees on the building steam system or LTHW loop for connection of a temporary boiler for emergency heat. The backup system shall be sized for all building loads, including domestic hot water, humidifiers, sterilizers, autoclaves, etc. Consult with the Project Manager, HSPP, and Facilities Management Energy and Utilities Department for specific requirements.

The secondary heating water for a building shall be between 90-190°F for heating. The re-heat water temperature shall be reset down in the summer and if practical controls shall be provided to shut off the re-heat pump(s) in extremely hot weather.

Hot water re-heat systems and combined pre-heat and re-heat systems shall be variable volume with 2-way control valves. The hot water pump speed shall be controlled by an end-of-line differential pressure sensor. All control valves on heating coils shall be industrial grade-pressure independent type. Valves on pre-heat coils shall be normally open/fail open, valves on re-heat coils shall be fail in place.

Blender sections shall be provided on all AHUs other than single pass units to ensure that the outside air and return air are adequately mixed. Pre-heat coils on single pass AHUs shall have a recirculation pump on the pre-heat coil supply or return connection. Face and bypass dampers shall not be used on pre-heat coils.

Automatic control valves on humidifiers shall be normally-closed/fail-closed. Provide hard-wire safety circuit to fail valve closed to prevent saturation. Safety device shall be installed in duct work downstream of wetting distance of humidifier

7.4.5 VENTILATION

7.4.5.1 SOURCES/OUTSIDE AIR

Outside air intakes shall be sufficiently above exterior grade (30 ft or at third story level) and shall not draw in exhaust air from adjacent systems, loading docks, parking lots, emergency generators, emergency or ambulance vehicle entrances, chemical storage, sewer manholes or other external sources of noxious or toxic fumes. Consideration also shall include proximity to wind-blown dust from streets, fields and ground care activities, designated tobacco smoking areas, combustion by-products and biogenic materials related to evaporative cooling towers or intentional human contamination. Outside air intakes shall be far enough above grade to discourage or prevent criminal contaminations.

To avoid re-entrainment of hazardous or noxious sources of exhaust air into the building or into adjacent buildings' air intakes and other sensitive locations, wind tunnel testing or other modeling must be performed to ensure adequate dispersion of the exhaust sources. Any architectural barrier constructed to mask unwanted appearance of stacks, penthouse, mechanical equipment shall be evaluated for its effects on re-entrainment.

Mechanical plans shall include a ventilation matrix documenting ventilation calculation set points required by ASHRAE 62.1 including Zone Area (Az), Area Ventilation Rate (Ra), Zone Maximum Population (Pz), Population Ventilation Rate (Rp), Zone Ventilation Effectiveness (Ez), Steady-state CO2 Concentration (See ASHRAE Guideline 36), ASHRAE Occupancy Category, Source Air Handling Unit, Application of Demand Control Ventilation, and Type of Demand Control Ventilation Control (CO2, Occupancy Sensor, etc.). Include ASHRAE 170 calculations for UVA Health facilities.

7.4.5.2 MATERIALS

Duct sealer shall be mold-resistant water based low-VOC.

Internal thermal duct insulation liner shall not be permitted. Acoustical duct lining shall be epoxy, acrylic, synthetic latex or Mylar coated. During renovations all lined duct in the area being renovated shall be replaced.

Duct elbows must have turning vanes or an inside radius of at least ½ of the duct width. Transition elbows are not acceptable.

Filters shall be provided on both sides of heat recovery devices. A window and light shall be provided to allow viewing of filters without stepping into the exhaust air stream.

Perforated returns shall not be used.

7.4.5.3 DISTRIBUTION AND GENERAL EXHAUST

See Division 1 of the Specifications for additional dust control requirements. Ventilation systems in UVA Health facilities shall comply with ASHRAE 170.

Plenum returns are not permitted above suspended acoustic tile ceilings. (Where a plenum return is approved by a waiver to the Guidelines, lined "Z" ducts shall be provided on all return grills for sound attenuation). Plenum returns may be allowed in fully enclosed soffits for normal return air.

Within any UVA Health building all return, relief, and exhaust air shall be discharged directly to the exterior without relieving into any spaces that have interior connectivity to occupied spaces - including mechanical rooms and occupiable service enclosures.

All exhaust fans shall be located outside the building so there will not be any positively pressurized duct inside the building. Where a fan must be inside the building envelope it shall be mounted directly to the discharge plenum or louver to minimize the length of positively pressurized duct inside the building. Outlets of multiple exhaust fans shall not be manifolded together unless backdraft protection is provided.

The discharge velocity from the stacks of lab exhaust and other noxious exhaust shall be at least 3,000 fpm and the plume shall be high enough to clear nearby obstructions; for higher hazard exhaust a higher discharge velocity or wind tunnel evaluation may be required; this requirement applies to induced flow type fans as well as fans with straight stacks. Fan exhaust air velocities below 3,000 FPM are allowable if wind study results meet dilution criteria established for the odor or hazardous emissions and the study results are reviewed and accepted by EHS and OUBO.

Variable geometry nozzle devices are not allowable. Centrifugal fans with a vertical discharge are suitable for most lab exhaust; high dilution exhaust fans shall not be used. Outlets of rooftop exhaust fans for lab exhaust and other noxious exhaust shall be at least 7' above the top of the fan and at least 10' above the roof; this requirement applies to induced flow type fans as well as fans with straight stacks. Where exhaust fans have inlet bypass openings below the fan, the bottom of the bypass openings shall be above any nearby screens and obstructions and at least 7' above the roof.

Fans shall be positioned so as to allow ready access to all fans, motors, belts, drives, isolation dampers controls and attached ductwork. Fans shall have adequate space for removal and replacement of fan and/or fan parts.

Minimal exhaust requirements above Code requirements are:

1. Areas with sinks and/or microwaves: 50 cfm each.
2. Custodial rooms and rooms having mop or service sinks: 75 cfm each.
3. Showers, bathtubs, whirlpools, spas, etc.: 50 cfm exhaust each; 50 cfm per person for fixtures designed for more than one occupant unless demonstrated that less exhaust is required due to diversity.
4. Electrical and communications closets shall be exhausted unless a dedicated FCU is used for cooling.
5. Machine rooms for hydraulic elevators: 50 cfm.
6. Battery charging rooms: Not less than 0.5 cfm per square foot.

7.4.5.4 FIRE AND SMOKE DAMPERS

Specifications shall provide the following minimum to demonstrate compliance with Code requirements:

1. Description of the acceptance testing requirements with requirement that tests are to be witnessed by the University Building Official's office, and responsible State Fire Marshal Office for Capital Projects.
2. All fire dampers shall be dynamic unless the University agrees that the AHU will stop functioning in case of a fire.
3. Fire damper access doors in large ducts shall be a minimum of 24" x 24".
4. Where fire and smoke dampers are installed above ceilings and are not visible from floor level, a permanent label identifying the damper shall be attached to the ceiling/ceiling grid. Letters shall be at least ½" in height reading FIRE/SMOKE DAMPER, SMOKE DAMPER, or FIRE DAMPER.
5. When Fire/Smoke dampers are connected to the building fire alarm system and the damper load exceeds the fire alarm system relay ratings, Auxiliary (NON-FIRE ALARM) relays shall be provided to control Line Voltage for each damper on a circuit. Auxiliary relays shall be rated to support the damper load.
6. A complete list of installed dampers and test results shall be provided to the Project Manager at the conclusion of the acceptance testing. The list shall include the make, model, type, fuse link type and rating, damper location, Aim Asset ID, and test result. Project manager or designee shall ensure information is documented and maintained in Aim. Coordinate asset records with Facilities Management Maintenance Manager at fm-preventive-maint@virginia.edu.
7. For UVA Health facilities, the following additional requirements apply:
 - a. A barcode associated with the AiM Asset ID shall be affixed to the ceiling grid/access door where the fire/smoke damper is located prior to project turnover.
 - b. For each damper initiated by the fire alarm system, the address of the initiating device shall be identified in the AiM Asset record

Smoke damper actuation utilizing corridor detection is the preferred method for use in ducts that penetrate the corridor walls in the University Hospital.

Where smoke dampers are activated by duct smoke detectors with minimum air velocity requirements, BAS shall initiate closure of all smoke dampers associated with the particular air handling system when the system is stopped (schedule, maintenance, or failure). To avoid UUKL/UL864 requirement of BAS components, BAS closure of smoke dampers shall be facilitated in series with the fire alarm control of damper so as not to impact life-safety operation. BAS shall monitor position of any BAS-closed smoke damper that impedes more than 25% of total air handling system flow or is in the duct run of a controlling static pressure sensor.

7.4.5.5 SMOKE CONTROL SYSTEMS

Any smoke control system requiring a UL 864 listing shall be directly controlled by the fire alarm system and completely separate from the BAS. Smoke control systems shall stay within the capabilities of the fire alarm system. Specifications shall provide a description of the acceptance testing requirements.

The A/E shall review the Shop Drawings for compliance with Code and shall:

1. Verify the Underwriters Laboratory (UL) listings and classifications for the materials, components and equipment provided for the project result in a Code compliant smoke control system.
2. Provide a sealed statement indicating that the Shop Drawings submitted for the smoke control systems satisfy the requirements of the Contract Documents, the VUSBC.

3. The A/E shall provide the University Building Official's office with the approved Shop Drawings and a copy of the sealed statement.
4. Smoke detectors used to control smoke or fire/smoke damper operation shall be listed for use with the building fire alarm system.

The University Building Official's office and responsible State Fire Marshal Office shall observe the installed components of the smoke control system(s) and witness the smoke control system(s) performance tests. The A/E and contractor shall certify that the smoke control system(s) is complete.

7.4.5.6 LABORATORY VENTILATION DESIGN

1. Any project installing, modifying, or removing an exposure control device (ECD, e.g., laboratory chemical fume hood) shall contact Environmental Health and Safety (EHS) for coordination and review prior to the preliminary design (PD) phase.
2. All projects with laboratory space shall comply with the UVA Laboratory Ventilation Design Standards (linked on the OUBO website, <https://oubo.virginia.edu/udg.html>).
3. Any project installing new ECD's, making adjustments to the ventilation or exhaust system (e.g., rebalancing), or coinciding with a significant change in laboratory function (e.g., new principal investigator, new major equipment) shall contact the Office for Sustainability (sustainability@virginia.edu) and EHS prior to SD submission.

7.4.5.7 GAS DETECTION AND ALARMS

The design of any laboratory or facility intending to use or store hazardous gases or cryogenic liquids shall be reviewed by EHS to determine if detection, alarm and control systems should be or are required to be incorporated into the design. Additionally, spaces with quantities of cryogenic liquids that exceed the minimum threshold quantities in the compressed gas standard CGA P-18 shall have oxygen monitoring and purge exhaust and follow requirements of the standard.

Based on the review conducted by EHS, a typical gas detection system will include, but is not limited to the following:

1. Digital display monitors for users to see the gas concentration (% level) both inside and outside the room.
2. Oxygen deficiency sensors shall be zirconium dioxide when possible due to their longevity (~ 10 years). Type and location of sensors shall be determined during a hazard assessment.
3. Systems shall be remotely monitored by the UVA systems Control Center through the Keltron system when feasible; if not, they shall be monitored through the University approved BAS system.
 - a. Monitoring for Toxic and pyrophoric gases may be controlled by dedicated toxic gas monitoring systems (TGMS), which will be tied to the Keltron system.
 - b. Where the BAS is utilized for monitoring a gas detection alarm, the local controller and all upstream BAS infrastructure shall be powered from an approved emergency power source.
4. Alarms shall be both audio and visual, located within the room being monitored (multiple depending on the room layout, equipment design, sightlines, etc.) and in the corridor at any entrance to the room being monitored. Visual alarm shall be blue strobes for oxygen deficiency. Light trees (or red/white lights) shall be reserved for other gas monitoring.
5. Alarm set points shall be determined according to current OSHA and SCGIH exposure limits for a given gas. Some alarms will have 2 set-points.

- a. For oxygen deficiency monitoring, alarm set-points will be set to the following:
 - 19.5% of oxygen level, local and supervisory alarm.
 - 18% oxygen level, local and system alarm notifications
- b. Emergency purge exhaust may be initiated for all or certain alarm set-points, determined during the hazard assessment.
6. An alarm callback and emergency response protocol will be primarily authored by EHS to provide to Systems Control Center.
7. Standard warning sign templates will be created by EHS. The project is responsible for having the signs created and posted at the monitor locations inside the room and at the corridor entrance to the room.
8. Sensors and the associated systems shall be commissioned by the project to confirm all programmed alarm sequences initiate as designed (e.g., audio and visual alarms at each set-point, emergency shut-offs, purge exhaust, monitoring points on the BAS and Systems Control Center are visualized, etc.). EHS shall be present to witness the commissioning.
9. The projects shall document all relay sequences, sensor and monitor locations, dedicated exhaust ventilation details, etc. in the construction documents for the owner's future references.
10. After the system is commissioned, ongoing sensor calibration and maintenance is generally the responsibility of the principal investigator of facility manager owning the equipment.

7.4.6 AIR CONDITIONING

7.4.6.1 SOURCES

All air conditioning shall use chilled water from a University central plant unless another source is approved by the Facilities Management Energy and Utilities Department and the Operations Department. If chilled water is not currently available to a site but is planned to be available by the completion of a project, then that project shall be designed to utilize plant-chilled water.

On VRF systems provide isolation valves on all lines from distribution boxes. Where multiple condenser units are used in a VRF system, provide isolation valves for each condenser. VRF condensers shall be monitored by the University BAS. Designs for VRF systems shall specify the type and quantity of refrigerant.

Water-cooled equipment and condensing units using domestic, potable water on a single-pass cycle are prohibited. Where a process water system is needed, it shall be served by the building chilled water system through a heat exchanger and shall have filters after the process water pumps. Process water systems shall be capable of providing 60 psi differential pressure across the most remote load but can be an open loop with a tank or a closed loop.

Environmental Resources shall be notified of any addition, removal or modification (i.e., refrigerant type change) of any equipment containing 50 lbs. or more of refrigerant in order to maintain the University's permit documentation accordingly.

7.4.6.2 REFRIGERATION SYSTEMS

Refrigerant sensors, which initiate both an audible and a visual alarm outside the room are required. All alarms shall be connected to the BAS. Rooms with the potential for a refrigerant leak shall be mechanically ventilated.

Refrigerant from all equipment, regardless of size, shall be recovered prior to disposal. Evacuated equipment must be labeled using either a special sticker or permanent marker noting that all refrigerant has been evacuated and the date of the evacuation. The contractor shall not demolish

the equipment until notified in writing by Facilities Management that the refrigerant has been removed. When a waiver has been granted for the contractor to remove refrigerant the specifications shall call out ODS Section 608 of the Clean Air Act.

7.4.6.3 MATERIALS AND EQUIPMENT

See 4.4 Exterior Domestic and Fire Service Water Piping.

Butterfly valves on the chilled water in main mechanical rooms including around the chilled water pumps shall be cast steel class 150 high performance lugged butterfly valves with M-filled Poly Tetra Fluro Ethylene (PTFE), Xtreme or better seat and seals with double offset seats and gear operator; high performance ball valves may be used on pipe up to 4". There is no special temperature rating. Acceptable manufacturers for high performance ball and butterfly valves are Adams, Bray, Jamesbury, and Zwick.

Butterfly valves on the chilled branches (other than around the heat exchangers and pumps) shall be class 150 lugged with stainless steel or nylon coated ductile iron disks (aluminum-bronze disks shall not be used); ball valves may be used on pipe up to 4". There are no special temperature rating, other specific requirements or brand preferences.

If copper is used, a brass nipple at least 6" long shall be used where the copper joins the University ductile iron chilled water distribution pipes. Copper chilled water lines shall be type L hard drawn. Dielectric unions shall not be used.

Flange gaskets on chilled water shall be rubber, PTFE, EPDM or other similar material; paper/compressed fiber gaskets shall not be used.

Chilled water distribution piping inside buildings can be welded seam steel pipe with threaded, welded, or flanged joints (mechanical joints are not allowed on steel pipe); or type L copper with either soldered or mechanical joints. PVC pipe shall not be used.

All fittings on chilled water pipe shall be Class 150 or better. Victaulic fittings used on chilled water pipe shall use stainless steel bolts and shall not use zinc plated bolts.

Pumps shall be enclosed in a waterproof insulated metal box, constructed of minimum 18-gage galvanized or stainless steel. Box shall be screwed, have bolts with wing nuts or quick connect latches to facilitate easy removal and reinstallation. The box shall be sturdy enough for a person to stand on.

Chilled water coils shall be sized for 44°F supply water temperature and 62°F return water temperature at peak load conditions however a lower return water temperature can be used if the coil size is excessive. During off peak conditions it is acceptable for the return water temperature to be above 62°F.

Chilled water coils shall have a maximum of 450 feet per minute face velocity, 6 rows and a maximum of 12 fins per inch however more rows will be allowed if the air resistance is less than 1/2" of water. The coil face area can be as large as needed to obtain the required performance however a lower return water temperature can be used if the coil size is excessive.

Chilled water coil control valves shall be two-way industrial grade pressure independent control valves. For CHW coils located in unconditioned spaces, dedicated outside air units, and units with outside air connections but without preheat coils, CHW valves shall be installed on the supply lines and fail closed upon activation of freezestat safety circuit. A check valve shall be installed on the return line to isolate system CHW pressure from coil. Separate flow control devices such as circuit setters, balancing valves, etc. should not be used. PT ports shall be provided across the control valve for flow and DP verification. Ports may be integral to the valve body or provided in-line piping.

Cooling coil casings and drain pans shall be stainless steel. All structural supports, etc. in air handling units immediately downstream of humidifiers shall be stainless steel.

In UVA Health facilities, all AHU cooling coils, including duct-mounted trim coils, shall be provided with UV-C coil disinfection systems. UV-C system shall be provided with remote ballast enclosures with status indicators mounted exterior to the air stream. BAS monitoring and control shall be provided in addition to manual and door-mounted safety switches.

UVA Health facilities shall use mechanical flange gaskets.

Cooling tower fans shall have variable frequency drives (VFDs) and aluminum fan blades. Condenser water pumps shall have VFDs unless Facilities Management Energy and Utilities Department agrees that an engineering and economic analysis indicates that they are not feasible or are not in accordance with manufacturers recommendations. Cooling tower make-up water shall be filtered.

7.4.6.4 CONTROLS

Chilled water loads shall be variable volume using end of line differential pressure to control pump speed. The end of line differential pressure can also be measured across the most remote-control valve.

The chilled water service entrance shall have a thermal energy meter package on the supply as well as manual isolation valves on the supply and return. The Contractor shall provide a thermometer or temperature gauge on the supply and return. The Contractor shall provide pressure gauges and sensors on the supply and return valve. A supply pressure sensor, differential pressure sensor and pressure relief valve shall be provided at the most remote load. The Contractor shall provide a full size bypass around the building chilled water pump with a strainer and check valve, and temperature and pressure gauges and sensors downstream of the pump and bypass. A back up pump is only required for critical loads. A "bridge" connection between the supply and return shall not be provided.

All chilled water loads above 600 feet elevation shall be served by a dedicated "high zone" chilled water loop with the heat exchanger and pump located just below 600 feet.

7.4.7 COOLING COIL CONDENSATE

7.4.7.1 REMOVAL

Cooling coil condensate recovery and reuse shall occur whenever cost effective means to do so are available. Example strategies include injection into the building chilled water return, or routing to a chilled water plant/cooling tower sump. Coordinate with Energy and Utilities. For release into landscaping, a French drain shall be utilized if it can be terminated within landscaping at least 2 feet from the building exterior wall. If a French drain cannot be utilized, a sanitary drain or roof drain are acceptable alternatives.

7.4.7.2 MATERIALS

Cooling coil condensate lines can be type L or M copper, PVC or CPVC. Galvanized steel pipe shall not be used. Cooling coil condensate lines shall have cleanouts that allow access of all branches of the condensate drain system. An air gap of at least two pipe diameters shall be provided at the discharge.

7.5 FIRE PROTECTION SYSTEMS

7.5.1 GENERAL

In addition to required building codes, automatic fire suppression sprinkler systems shall be installed in new buildings, additions and in renovations of existing buildings consistent with University administrative policy.

Knox-Boxes shall be 4400 series. Information regarding the ordering of boxes is available by contacting the Office of Fire Safety.

For UVA Health facilities, automatic fire suppression sprinkler heads shall be concealed type in all ceiling areas with custom color cover plates to match ceiling paint color. In mechanical areas and areas without ceilings they shall be brass.

In buildings of two or more stories, standpipes shall occur in each exit stair with fire department hose connections at each level. Floor Control Valve assemblies are required on all floors. C&O threads shall be used on fire hose connections in buildings located in City of Charlottesville and Albemarle County (C&O thread count shall be 3.28x8).

Renovations of spaces that have fire hose cabinets shall remove hoses.

Fire extinguishers and cabinets shall be specified by the A/E. Cabinets shall be Contractor purchased and installed. Extinguishers shall be Owner purchased and installed.

Dry, Pre-Action and Deluge type sprinkler systems of 150 gallon or larger shall be equipped with a nitrogen generator to supply pressurized air. Use of nitrogen containers/tanks to supply system is prohibited. Dry, Pre-Action and Deluge systems under 150 gallon may be equipped with Vapor Phase Corrosion Inhibiting (VpCI) type equipment in lieu of a nitrogen generator. Nitrogen generators and VpCI equipment shall be listed for use with fire protection systems. System shall meet all additional requirements shown in NFPA 13 for nitrogen systems used to maintain system air pressure.

7.5.2 FIRE PROTECTION SPRINKLERS

In buildings requiring sprinklers, fire pumps or fire protection standpipes, a separate backflow preventer for fire protection shall be provided. Fire protection service shall not be through the domestic metered water system. Sprinkler control valves located above suspended ceilings shall be marked with a "Sprinkler Control Valve" sign on the ceiling panel.

7.5.2.1 SPRINKLER HEAD DATABASE

The University maintains a sprinkler head database for all sprinkler heads installed in its facilities, both existing and new. The database is to be updated whenever a new building is ready to occupy; whenever the fire protection system is added to, upgraded, or replaced in existing facilities; and whenever sprinkler heads in an existing system are replaced for whatever reason. At the completion of a project, the sprinkler contractor shall supply an "as built" inventory. Submit the [Sprinkler Inventory Form](#) to fireprotection@virginia.edu.

7.5.2.2 SPRINKLER DESIGN DOCUMENTS

The A/E shall provide project specific Drawings and Specifications that define a Code-compliant fire sprinkler system. Performance criteria do not meet this intent. Construction Documents shall indicate that changes to the design during construction shall be considered substitutions. Changes shall be submitted to the University Building Official for review. The A/E shall confirm that the fire

sprinkler system is complete, functional and Code compliant.

Drawings shall provide the following minimum information to demonstrate compliance with the requirements of the VUSBC and NFPA 13:

1. Small scale drawing showing locations of water hydrants, test and flow hydrants (for water flow tests) and routing of underground pipe. Indicate the water flow tests results, the date and time taken, and who conducted the test.
2. Identification of all existing sprinkler systems and standpipe systems, including any new connections to existing systems.
3. Sprinkler riser diagram with appropriate fittings, accessories, sizes, alarms, valves, etc. noted.
4. Location of all system drains, inspector's test station(s) and associated discharge/ draining piping.
5. Requirements 1 – 4 above may be omitted for minor alterations to an existing sprinkler system involving only re-location of existing sprinkler head locations without extensive branch or main piping reconfiguration. For minor alterations meeting this criteria, submit drawings showing only the changes proposed to the existing system, identifying existing piping and heads to remain, existing heads to be removed/relocated, changes to piping, and new/relocated sprinkler head locations. The addition of heads to an existing system requires hydraulic calculations or justification by "pipe schedule" design method by the A/E.

Specifications shall provide the following minimum to demonstrate compliance with the requirements of the VUSBC and NFPA 13:

6. Wording that the type of systems, the location of major components, the quantity, type, coverage, location of sprinklers and distribution systems are not to be altered by the Contractor without approval of the A/E and University Building Official.
7. Description of the acceptance testing requirements, and which of the acceptance tests are to be witnessed by the University Building Official's office.

Shop Drawings (Working Drawing Plans, product data and calculations, or minor alteration plans) are to be reviewed by the A/E for compliance with Final Construction Documents and the Code. Prior to submittal to OUBO, the A/E shall:

1. Provide a "sealed" statement, attached to the reviewed Shop Drawings, indicating that the fire suppression sprinkler Shop Drawings (Working Drawing Plans, product data and calculations, or minor alteration plans) satisfy the requirements of the Contract Documents and the VUSBC and NFPA 13.
2. Provide the University Building Official with two copies of the approved complete fire suppression sprinkler Shop Drawings.

Fire suppression sprinkler systems are to be acceptance tested in accordance with Code requirements. The University Building Official's office shall observe the installed fire suppression sprinkler system and witness the fire suppression sprinkler system performance tests. The A/E and contractor shall certify that the fire suppression sprinkler system is complete prior to testing. Similar requirements to the above are required for fire suppression systems utilizing clean agents.

7.5.2.3 INSTALLATION, INSPECTION AND ACCEPTANCE

Fire department building and riser connections shall be coordinated through the UVA Fire Marshal (for Academic System buildings) or UVA Health Physical Plant Fire Protection Inspector (for UVA

Health buildings). The location of Post Indicator Valves and Fire Alarm Control Panels shall be approved by the authorized person from the Charlottesville Fire Department, or appropriate jurisdiction for projects not located on University Grounds. Signage noting the exterior location of the FDC and PIV shall be 12"x12".

Specifications shall indicate that following the completed installation, Facilities Management or its independent consultant will inspect the installation and report any deficiencies prior to final inspection by OUBO.

7.5.3 FIRE PUMPS

Where the building characteristics are such that the water supply requirements of a fire sprinkler system/standpipe system cannot be provided by a public water system, an automatically controlled fire pump shall be designed into the fire suppression system. The A/E shall provide project specific drawings and specifications that define a Code compliant fire sprinkler system that includes an automatic fire pump(s). Performance criteria do not meet this intent.

Fire pump controllers shall have digital volt/amp meter.

Fire pumps that are powered by fuel burning equipment must also follow the requirements in 7.6.2.8 Emergency Generators & Other Fuel Burning Equipment.

7.5.3.1 FIRE PUMP DESIGN DOCUMENTS

Drawings shall provide the following minimum information to in addition to the requirements of the VUSBC, NFPA 13, and NFPA 20:

1. Show the location of electrical components of the fire pump, driver, fire pump controller, and ancillary electrical components, and provide details.
2. Show the location, size, and routing of the conduits and conductors serving the fire pump, driver, fire pump controller, and ancillary electrical components.
3. Provide details of the electrical components serving the fire pump, driver, fire pump controller, piping, components and piping specialties.
4. Where multiple fire pumps or multiple sources of power are required, provide a diagram that defines all of the applicable components and sequence of operation.

Specifications shall provide the following minimum information to in addition to the requirements of the VUSBC, NFPA 13, and NFPA 20:

1. Complete specifications to reflect the systems that are defined on the drawings.
2. Wording that indicates that Fire Pump and ancillary components are not to be altered or modified without the written approval of the A/E and the University Building Official. Changes to the design depicted within the Construction Documents shall be considered "Substitutions" in accord with the General Conditions of the Construction Contract and are to be documented by Change Order.
3. A description of the Acceptance Testing Requirements, to be witnessed by OUBO.
4. Where an existing fire pump is to be used in the project, the performance and condition is to be established and validated. Submit a copy of the recent Report of the Fire Pump Inspection, Testing and Maintenance compliant with the Virginia Statewide Fire Prevention Code.
5. Shop Drawings (product data, sketches and certified shop test pump curves) are to be reviewed by the A/E for compliance with the contract documents and Code, including verification of the Underwriters Laboratory (UL) listings and classifications for the

materials, components and equipment provided. Two copies of the approved Shop Drawings, with a sealed statement that they satisfy the requirements of the Contract Documents and Code shall be provided to the University Building Official's office.

6. Fire pump(s) is (are) to be acceptance tested in accord with Code requirements. The University Building Official's office shall observe the installed fire pump(s) and ancillary components, and shall witness the fire pump(s) performance test. The A/E and Contractor shall certify that the fire pump installation is complete.

7.5.4 PROTECTION DURING CONSTRUCTION

In renovation projects where the building is to remain occupied during construction, the following statements shall be shown on the Life Safety cover sheet in the Contract Documents:

All existing fire protection systems shall remain operational during construction. If temporary shutdown is necessary, the system shall be returned to operational condition as soon as possible and no later than the end of each working day prior to the Contractor leaving the job site. The Contractor is to notify the University Fire Marshal prior to any necessary shutdowns. Any necessary shutdowns shall not affect other areas not involved with this construction project.

All operational standpipes are to be maintained at all times in accordance with VEBC 1206.

Sprinkler systems in areas being renovated shall be operational when the Contractor leaves the site each day and in accordance with VEBC 1207. A fire watch shall be provided at all times that a sprinkler system is inactive.

7.6 ELECTRICAL SYSTEMS

7.6.1 BUILDING ELECTRICAL SYSTEMS

7.6.1.1 GENERAL

7.6.1.1.1 IDENTIFICATION

1. All electrical equipment and circuits shall be marked and labeled for identification and safety purposes.
2. Laminated nameplates shall be used on the exterior surfaces of all electrical equipment.
3. Junction and pull boxes may be labeled using a black indelible marker. Label to be on the exterior of the cover unless box is exposed in finished locations.
4. Receptacles and other wiring devices are to have a label on the back of the cover plate indicating circuit(s) to device.
5. Emergency receptacles shall be red in color and have a label on the cover plate indicating the panel board and the circuit number.
6. Emergency light fixtures shall be identified by a permanent red dot/circle on the frame.
7. Conductor color-coding shall match the existing building convention. If none exists, the phase colors for 120/208V systems shall be red, blue, and black; neutral shall be white. The phase colors for 277/480V shall be yellow, orange, and brown; neutral shall be grey.
8. A copy of the one-line diagram shall be laminated and be permanently mounted near the main switchgear. For renovation projects changes to the one-line diagram shall be added and posted.

7.6.1.1.2 CALCULATIONS

The following calculations shall be submitted to OUBO with the Contract Documents:

1. Building short circuit
2. Building load
3. Feeder voltage drop
4. Generator load calculations. Where a generator requires stepped load starting, the load sequence, time delays, and how the stepping will be achieved shall be indicated on the drawings.

7.6.1.1.3 ARC FLASH STUDY AND LABELS

1. An arc flash study shall be completed for all new buildings. For renovations, existing arc flash studies shall be updated by the engineer or contractor to reflect changes. Where a study has not previously been done, one shall be completed, at OUBO's determination, if a significant portion of the electrical system is being updated as part of the project.
2. Arc flash analysis shall be completed using SKM Power Tools software. Submit a copy of the arc flash study to OUBO after approval from the engineer. A copy of the project SKM file shall be submitted to UVA.
3. An "infinite bus assumption" shall not be used for arc flash calculations. All utility data should be site-specific and requested from UVA or Dominion.
4. Contractor shall provide arc-flash labels indicating equipment name, system voltage, limited approach boundary, restricted approach boundary, arc flash boundary, incident energy values in cal/cm² and the corresponding working distance in accordance with NEC110.16 and NFPA 70E. Additionally, use red "DANGER" headers on all labels indicating an incident energy value of 40 cal/cm² or more, and orange "WARNING" headers on all labels less than 40 cal/cm², in accordance with ANSI Z535.4.

7.6.1.2 DEMOLITION

All wire shall be removed back to the last active device, junction box or panelboard. All exposed and/or accessible conduits and boxes shall be removed. When telecommunications systems are replaced, abandoned wire and cabling shall be removed with walls and ceilings restored to their pre-existing condition. Coordinate with ITS personnel through the Project Manager.

The Contractor shall coordinate the disposal of PCB ballasts and fluorescent lamps through the Project Manager. Coordinate disposal of tritium powered exit signs (ionizing radiation hazard) with Environmental Health & Safety (EHS).

7.6.1.3 SWITCHGEAR, PANELBOARDS AND TRANSFORMERS

Bussing shall be copper. Separate neutral and equipment grounding busses shall be provided. Circuit breakers shall be bolt-on type. Load centers are not permitted. Series rated equipment is not allowed. All panelboards shall have an internal main breaker and manufacturer-installed guards that provide a dead-front condition with the cover removed for maintenance. Main-lug-only panels shall not be used.

7.6.1.3.1 SWITCHGEAR

Building switches and switchgear shall be located in appropriate electrical rooms. Switches (and other electrical equipment) will be permitted, by exception, on the exterior of buildings with

an approved D&F. Provide transient voltage surge suppression (TVSS) at main switchgear (for new buildings and major renovations). UVA Health facilities shall incorporate BAS monitoring of failed TVSS devices with alarms configured to alert HSPP.

7.6.1.3.2 PANELBOARDS

Printed schedules shall be provided for all electrical construction involving panelboards and switchboards. Handwritten schedules are not allowed, and all handwritten notations on the schedule or panel cover shall be included on a new printed schedule. The electrician will verify all circuits as noted on the schedule to be accurate before work is complete. Schedules shall indicate all loads, and their locations using final room numbers, served by each breaker. Spares shall be left in the OFF position.

All new panelboards shall have 20% spare capacity for future use. Provide four 1" conduits stubbed out into an accessible ceiling space for new recessed mounted panelboards.

7.6.1.3.3 LOW VOLTAGE TRANSFORMERS

Dry-type transformers shall have copper windings. Transformers shall meet or exceed the requirements of NEMA TP-1 for energy efficient transformers.

Transformers with the capacity to store 55 gallons or more of petroleum oil-based fluids are subject to University Spill Prevention, Control and Countermeasures (SPCC) Plan. Notify the Power System Distribution Manager and SPCC Program Manager or FM SPCC Coordinator of the new equipment so it may be added to the transformer inventory.

K-factor transformers shall be used where large quantities of harmonic producing loads are present.

7.6.1.4 ELECTRICITY METERING

See Appendix B: Utility Metering Requirements.

7.6.1.5 CONDUITS

1. All wiring shall be run in conduit, surface metal raceway or cable tray. Use EMT conduit for indoor applications, unless exposed to physical damage. UVA Health facilities prohibit the use of set-screw type EMT fittings, compression fittings are required. In outdoor applications, use rigid galvanized steel conduit where exposed and rigid non-metallic (PVC) for underground installations. Exceptions are noted below.
2. All conduits shall be concealed in finished areas. Surface mounted raceways may be used only for horizontal distribution of electrical and data cabling in computer rooms, computer classrooms and laboratories. Pre-existing conditions of surface mounted wiring and conduit does not constitute permission to add surface mounted hardware and raceway.
3. Minimum conduit size shall be $\frac{3}{4}$ ". Exception: where light fixtures will only accept a $\frac{1}{2}$ " whip.
4. MC cable may be used for 20-amp branch circuits where allowed by code and under the following conditions:
 - a. Wiring shall be in conduit from the panel to a junction box located above the ceiling in the space served by the branch circuit. MC cable may not be used for through wall penetrations.
 - b. Wiring from the junction box to lights or receptacles may be MC cable, up to a distance of 25 feet.
 - c. UVA Health facilities: Use hospital grade MC cable, Southwire Series HCF MCAP or equivalent as manufactured by AFC MC-STAT. Interlocked armor shall meet the NEC

517.13 grounding requirement and shall meet Federal Specification A-A59544. Fittings shall be listed for use with interlocking armor.

- d. MC cable shall not be used for emergency circuits or fire alarm wiring.
 - e. MC cable shall not be exposed, surface mounted, or used in electrical or mechanical rooms, closets, or shafts.
5. Flexible metal conduit (FMC) or liquid tight flexible conduit (LFMC) not exceeding 6' in length shall be used only for light fixture whips or for connections to motors or equipment subject to movement or vibration. Exceptions may be granted for renovation projects allowing over 6' of flexible conduit where:
 - a. In locations that are not accessible
 - b. For the connection of light fixtures, provided they have an insulated ground wire sized in accordance with NEC
 - c. In connections to systems furniture and under floor power requirements for computer server room applications
 6. EMT conduit from the communications or control wiring (under 50V) wall outlet box may terminate several inches above the ceiling where lay-in ceiling tile is used. Cabling above the ceiling shall be neatly bundled and attached to or independently supported from the building structure above. Wiring, conduit or cable shall not be laid on the ceiling system or attached to the ceiling suspension wire.
 7. All empty conduits shall have a 65 lb. test polymer (or equivalent) pull string tied off at both ends.

7.6.1.6 WIRING

1. All conductors shall be copper with 75°C insulation or better. Aluminum conductors may be used on feeders with an ampacity of 200 amps or greater. All terminations on aluminum conductors must be with crimped fittings, and must be bolted and torqued. Set screw type terminations are not permitted with aluminum conductors.
2. All power and lighting circuit conductors shall be #12 AWG or larger. #8 AWG and larger shall be stranded conductors and #10 AWG and smaller shall be solid conductors.
3. Minimum control wires shall be #14 AWG and minimum signal wire no smaller than #18 AWG unless otherwise recommended by manufacturer.
4. No more than three single phase circuits or eight current-carrying conductors shall be run in a single conduit.
5. All new circuits shall have a green equipment-grounding conductor sized per NEC.

7.6.1.7 DEVICES

Ground fault circuit interrupter outlets or breakers are required on all power outlets within 6' of water sources. Where the presence of water or grounded surfaces contributes to a hazardous environment, ground fault protection is required.

All devices shall be 20A, heavy-duty specification (minimum) grade devices. Residential grade devices are not permitted.

Receptacles shall be mounted with the ground pole in the UP position unless otherwise directed.

Academic Building Requirements: Receptacles served from a generator shall be marked with a University approved colored faceplate.

UVA Health requirements:

1. Light switches shall be ivory in color.

2. All receptacles used in UVA Health shall be hospital grade.
3. Normal power receptacles shall be ivory in color and emergency power receptacles shall be red in color.
4. Cover plates shall be brushed aluminum, chrome or stainless steel with embossed circuit designations.

7.6.1.8 LIGHTING

See Chapter 8: Green Building Standards for Lighting Properties Table.

For exterior fixture requirements, see 4.12.1 Site Lighting.

The following energy conservation measures shall be used:

1. Building designs shall take maximum advantage of natural light. Ambient light sensors, dimmers and programmable controllers are to be used where large amounts of glazing are present.
2. Occupancy sensors shall be set to Manual ON, Auto OFF and have integral light level sensor where appropriate.
3. Operation of the occupancy sensors; including Manual ON, Auto OFF operation; shall be verified by the commissioning agent.
4. All spaces shall have a control device in the space to enable the lights after hours. Enabling this control device after hours should not enable the lights in the entire building. This control shall be verified by the commissioning agent.
5. Exterior lighting shall be controlled through the use of photocells and not through BAS.
6. Minimize glare in offices or office areas where computers are used by implementing such methods as low-brightness luminaires, indirect lighting and/or minimizing luminance ratios between different surfaces.
7. LED lamps shall be used for lighting.
8. 12-hour timer switches with "hold on" option are to be used to control lights in mechanical rooms.
9. The use of 2' x 2' light fixtures shall be limited to those areas that are architecturally appropriate. Tandem wiring of lighting fixtures is not allowed.
10. Non-catalog and custom lighting fixtures shall not be used unless economically justified and approved by Facilities Management. Such fixtures shall be UL listed/labeled.

7.6.1.8.1 FLUORESCENT LAMPS

New and replacement fixtures shall be LED. The color temperature shall be coordinated with the user. Fluorescent lamps are for maintenance of existing fixtures.

7.6.1.8.2 LED LUMINAIRES AND LAMPS

All LED luminaires or LED luminaire replacement kits shall be tested in accordance with IESNA LM79, Approved method: Electrical and Photometric Measurements of Solid-State Lighting Products and IESNA LM80, Measuring Lumen Maintenance of LED Light Sources. The Warranty of all LED products shall be five years minimum for both LED modules and drivers.

Conversions of luminaires from fluorescent to LED technology will be accomplished with a complete retrofit kit. "Plug-and-play" type LED bulbs that work with existing fluorescent ballasts shall be permissible. Removing existing fluorescent ballasts to allow for direct-wire LED bulbs is prohibited.

Exit signs shall be LED type. Notify EHS if Tritium signs (ionizing radiation hazard) are used. Exit

signs in UVA Health buildings shall have red lettering and graphics.

In critical spaces in Health Systems buildings, LED fixtures shall be provided with remotely mounted drivers in an accessible location external to the critical space (e.g. operating rooms, procedure rooms, imaging rooms).

7.6.1.8.3 LIGHTING LEVELS AND CALCULATIONS

Interior lighting levels shall comply with the recommended footcandle (fc) levels found in IESNA Lighting Handbook, latest edition. Lighting levels for office spaces shall be 30 fc. Lighting levels for mechanical and electrical rooms shall be 20-30 fc. Lighting level for telecommunications rooms or closets shall be 50 fc. The use of task lighting is to be maximized. The illuminance ratio for maximum to minimum light levels shall not exceed 10:1 in any occupied space.

Footcandle calculations for normal and emergency operation shall be submitted with the Contract Documents. Design fc, IES illuminance category, calculation plane height and any weighting factors used, shall be indicated on the fc calculations. Submit fixture cuts of all proposed fixtures at the Preliminary Design submittal. Submit any revised or added fixture cuts with the Contract Documents.

7.6.1.8.4 INSTALLATION REQUIREMENTS

Recessed light fixtures are to be suspended from the structure. Do not support solely from the ceiling suspension system.

The locations of light fixtures in mechanical spaces shall be field coordinated so that access to lights for relamping, maintenance and replacement is maintained with appropriate illumination levels. For safety reasons light fixtures will be located at or around equipment so that maintenance personnel will not obscure the required illumination.

7.6.1.8.5 CLASSROOM LIGHTING CONTROL TEMPLATE

Classroom lighting controls shall be coordinated alongside audio-visual requirements through the ITS-Classroom Support during design development (crdesign@virginia.edu). See also 1.4.5.3 Audio-Visual Technologies.

7.6.1.8.6 UVA HEALTH REQUIREMENTS

1. All patient corridors shall use LED flat panel fixtures.
2. Some specialty fixtures may be allowed in public areas and high-profile spaces with written approval from HSPP.
3. Offices shall use direct/indirect lights.
4. Patient room light fixtures shall be multi-function, providing indirect ambient, direct reading, examination, and nurse/night light.
5. Exam lights are typically owner furnished and contractor installed. Confirm specification and selection with UVA Health Clinical Engineering Systems department.
6. Where medical uses, such as MRIs, or diagnostic and treatment areas require special lighting specifications, their use is approved.

7.6.1.9 MOTORS AND STARTERS

Provide electronically commutated motors (ECM) for all motors two horsepower and below. Use higher horsepower motors when available. ECMs shall include a modulating speed controller. Where ECM speed is to be modulated by BAS, ECM shall accept a hardwire analog speed reference.

ECMs and their speed controllers shall not be stepped (High/Medium/Low) type.

Provide variable frequency drives (VFDs) for all fans and motors above 2 horsepower.

Motors ¾ hp and larger shall be 3-phase, using the highest available appropriate voltage. All such motors shall be equipped with permanently lubricated bearings.

All motors shall be NEMA Premium Efficiency type, complying with the requirements of the latest edition of NEMA MG 1, with a service factor of 1.1 or better. All motors between 1 and 200 hp shall exceed these standards where possible and economically justified.

Sheaves and V-belts on belt driven equipment shall be rated for 150% of motor horsepower. Belts shall be guarded to provide safety protection, ventilation and cool operation. Solid sheaves and band belts shall be used to minimize vibration in multiple V-belt driven equipment.

All motors, except light-duty fractional horsepower motors, shall be provided with motor controllers. Controllers shall provide under-voltage protection when used with momentary contact control devices and under-voltage release when used with maintained contact control devices. Controllers shall also provide phase-loss (single phasing) protection.

A lockable disconnecting means shall be provided at all motor locations within sight (50') and reach of motor location. All motors and their disconnecting means shall be clearly marked to identify the motor that the disconnect serves. Circuit breakers shall not serve as motor disconnecting means.

7.6.1.10 VARIABLE FREQUENCY DRIVES

All variable frequency drives (VFDs) shall be able to communicate with Building Automation System controls. Where multiple VFDs are fed from the same panelboard or MCC, the contractor shall provide a harmonic analysis, at the highest point of commonality, to show compliance with IEEE 519. Include analysis with drive submittals. VFDs shall be pulse width modulated (PWM) type using IGBT technology.

VFDs shall be provided with by-pass isolation switches. In UVA Health, VFDs shall be 12-pulse for higher than 100 hp and greater and 6-pulse drives for less than 100 hp. A 5% impedance line-reactor shall be included with all new VFDs unless there is already upstream filtering in place or harmonic analysis indicates a different harmonic mitigation strategy. Any VFD motors with more than a total length of 100 feet of cable shall be provided with a dV/dT filter installed at the load side of the VFD. Where multiple motors are powered from a single VFD, the sum of all motor leads shall be used to determine the total cable length.

7.6.1.11 BUS DUCT INSTALLATIONS

Include the following paragraph in specifications for bus ducts:

“The bus duct shall not be energized until the A/E has received and reviewed a letter from the contractor and a Commonwealth of Virginia Licensed Professional Engineer provided by the contractor, certifying that the installation was inspected, and it was determined that the entire bus duct system has been properly installed in accordance with the Final Construction Documents, including approved Shop Drawings and/or manufacturer’s instructions for this Project.”

The certification of this work shall include the torque pressure used to tighten bolts at all spliced joints in the bus duct system.

7.6.1.12 LIGHTNING PROTECTION SYSTEMS

For new facilities, roof replacements, and solar array installations the A/E shall evaluate the building to determine if a lightning protection system is required. The risk assessment shall be performed

according to Annex L of NFPA 780 *Standard for the Installation of Lightning Protection Systems* (current edition as defined by the *National Electrical Code* NFPA 70: 250.106). If the assessment results indicate that lightning protection is recommended, a lightning protection system shall be installed.

Provide a note on the project cover sheet or electrical cover sheet specifying if a lightning protection system is required. Risk evaluation documentation shall be made available upon request.

Photovoltaic array installations shall be provided a minimum of a lightning arrester either at the array or at the output of the inverter to protect downstream equipment regardless of the risk factor.

7.6.1.12.1 LIGHTNING PROTECTION SYSTEM LABELING AND CERTIFICATION

Initial certification or re-certification by inspection is required for all lightning protection systems that are installed or modified as part of a construction project. The inspection shall be performed by a Lightning Protection Institute certified inspector master certificate inspection. The inspection shall certify the final installation to obtain a master label for all elements to include the facility and services entering the facility.

The installation contractor shall provide a third party master label inspection to OUBO prior to project close out. Should the contractor not be able to obtain a complete master label, the contractor shall provide the remaining certification at their expense prior to issuance of a final Certificate of Use and Occupancy or Building Permit Close Out.

7.6.2 SPECIAL SYSTEMS

7.6.2.1 TELECOMMUNICATIONS

See also 1.4.5.2 Information Technology Services (ITS) the ITS guidelines and 1.4.3.6 Emergency Telephones.

The University owns its own telephone system and integrates its information technology and cabling for telecommunications under management by the Department of Information Technology and Communications.

Contractor shall provide a system of conduits, outlet boxes, backboards, etc., to support the installation of cabling by others, unless otherwise directed by the Project Manager in writing.

The conduit or raceway system shall be sized to accommodate the foreseeable uses of the building plus 25%. Outlet boxes shall be a standard 4" x 4" outlet box with single gang plaster ring and 1" C to above accessible ceiling. Conduit end shall be bushed. All buildings, including residential facilities, require information technology outlets, unless otherwise directed by Project Manager in writing.

Telecommunications rooms/closets shall have a minimum of two 20A, 125V receptacle circuits and one NEMA L14-30R receptacle circuit. UVA Health IT closets shall have a minimum of one L6/30 receptacle. Quad receptacles shall be located at 48" on center on all walls and shall be clearly labeled. Telecommunications room receptacles shall be served by emergency power where available. Cable bundles through rated wall assemblies at telecom or electrical rooms shall be installed using a fire protection pass-through sleeve (Hilti "Speed Sleeve" or equivalent). Use of these sleeves at all rated wall assemblies is preferred in the health system.

Sleeves through floor assemblies for conduit, cabling or other penetrations shall extend at least 1" above the finished floor. Provide a minimum of four 4" penetrations per closet. In existing buildings the precise location of penetrations shall be marked on the site with an "X" mark on the floor or

wall for review and approval by designated Facilities Management personnel prior to coring. Provide a green grounding conductor back to the main service ground from each telephone backboard. Leave a minimum of 12" slack at the backboard for connection to equipment by others.

7.6.2.2 TELECOMMUNICATION CABLING STANDARDS

The Council on Information Management has adopted Standards for Telecommunications Cabling that shall be used when preparing designs related to telecommunications wiring for University-owned buildings.

The following standards of the Electronic Industries Association are referenced in the Telecommunications Cabling Standard:

ANSI/EIA/TIA-568-A Commercial Building Telecommunications Cabling Standard

ANSI/EIA/TIA-569 Commercial Building Telecommunications Pathways and Spaces

ANSI/EIA/TIA-570 Residential and Light Commercial Telecommunications Cabling Standard

ANSI/EIA/TIA-606 Administration Standard for the Telecommunications Infrastructure for Commercial Buildings

ANSI/EIA/TIA-607 Commercial Building Grounding and Bonding Requirements for Telecommunications

7.6.2.3 CABLE TELEVISION

Cable television services shall be provided in University residential facilities. Cable connection is obtained from the holder of the local cable franchise or from a University system as coordinated through the Project Manager.

Contractor shall provide a system of conduits, outlet boxes, backboards, etc. to support the installation of cabling by others unless directed otherwise by the Project Manager in writing.

Cable television services shall coordinate with Clinical Engineering in UVA Health areas.

7.6.2.4 SECURITY

The A/E shall determine in consultation with the Project Manager the application of security systems for each project. The issue of security is particularly applicable for computer operations, UVA Health facilities, residential facilities, and exterior access doors.

The A/E through the Project Manager shall consult the University of Virginia Police Department during the design of security systems to ensure that the proposed system meets Police Department recommendations for compatibility with existing systems and the adequacy of the proposed design.

Card reader access systems shall be required at a minimum of one major, visible building entrance as coordinated with the University Police through the Project Manager.

Security alarm systems are monitored at either the University Police Station on Route 250 West or at the Systems Control Center in the Leake Building. At a minimum, contractor shall provide a system of conduits, outlet boxes, backboards, etc., to support the installation of a security system by others unless directed otherwise by the Project Manager in writing.

7.6.2.5 CLASS 2 AND 3 ELECTRICAL CABLES

All cables including but not necessarily limited to data, voice, alarm, and security system cables and wires, installed in University-owned facilities shall be self-supported with an approved hanger

device when cables or wires are not installed in an electrical raceway. Cables shall be supported at no greater than twelve-foot intervals and securely fastened to the building structure. All cabling not installed in conduit shall be plenum rated.

All Class 2 wiring installed for the Building Automation System shall comply with wiring standards contained in UVA Automation Services' BAS Standards documents.

7.6.2.6 FIRE DETECTION AND ALARM SYSTEMS

7.6.2.6.1 CONSTRUCTION DOCUMENTS REQUIREMENTS

The A/E shall provide project specific drawings and specifications that define a Code compliant fire alarm system. Performance criteria do not meet this intent. The A/E shall confirm that the fire detection and alarm systems are complete, functional and Code compliant.

7.6.2.6.2 SPECIFICATIONS

1. Provide wording that the contractor shall not alter the location and type of fire alarm system initiating appliances, control and trouble signaling equipment, location of major components without written approval by the A/E and University Building Official.
2. Provide description of the acceptance testing requirements and which of the acceptance tests are to be witnessed by the University Building Official.

7.6.2.6.3 REQUIRED CALCULATIONS

1. Quantity and location of the audible alarms as indicated on the drawings to achieve the Code defined sound pressure levels in each of the respective spaces.
2. Required capacity of the secondary power supply attained.
3. Candela performance for alarm notification devices, including any provided with protective covers.

7.6.2.6.4 SHOP DRAWINGS

The A/E of record shall provide a "sealed" statement, attached to the reviewed Shop Drawings, indicating that the fire alarm Shop Drawings (Working Drawing Plans, product data, and calculations) satisfy the requirements of the Final Construction Documents and the Code [citing applicable National Fire Protection Association (NFPA) criteria].

7.6.2.6.5 SYSTEM REQUIREMENTS

The fire alarm system shall be a Siemens Cerberus ProFire Alarm Control Panel. The fire alarm system shall be provided with tone and voice evacuation subsystem as an extension or integral part of a building fire alarm system. A digital message repeater shall also be provided with a microphone allowing for local paging from the annunciator. Renovations to existing systems must remain compatible with the existing fire alarm control panel. All initiating and notification appliances shall be UL listed to be used with the fire alarm system.

Fire alarm devices (other than pull stations) shall be white for new buildings and where an entire floor is renovated. Where a portion of a floor is renovated, devices shall match the color of existing devices.

In vivaria, audible notification appliances provided shall not be in the audible range of rodents. UL listed appliances for that use shall be provided. Basis of design product is Silentone by Arrowmighit. With prior approval from OUBO, visual only notification appliances may be installed in vivaria and in their immediate vicinity.

All fire alarm systems and components should be serviceable by FM Fire Protection personnel or training shall be provided by the manufacturer at the expense of the installing contractor.

Where new devices will be added to an existing system, they shall match the types of, or be compatible with, the system already in place unless otherwise directed by the Project Manager in writing. Devices added to an existing system shall be listed as compatible for use by the system manufacturer.

Fire alarm equipment that is obsolete and is no longer manufactured at the time of the system installation or during the warranty period shall be replaced by the installation contractor at no additional cost to the University.

7.6.2.6.5.1 Fire Alarm System Monitoring

All buildings with fire alarm systems shall have either the fire alarm panel (FACP) or remote annunciator at the main entrance or other location approved by the local fire department.

All fire alarm systems in University facilities in Charlottesville shall be monitored by the Facilities Management Systems Control Center (SCC) through extension of existing Keltron system. All projects should ensure that dry-type contact relay pairs are available from building fire alarm panel(s) for alarm, trouble, and supervisory conditions (points). Additional building information such as alarm on a floor-by-floor, or by-zone basis may be achieved through direct digital communication between Keltron system devices and building fire alarm system. In addition, where fire pumps are installed, there shall be normally open dry contacts for signaling up to four additional points for the Fire Pump Running, Fire Pump Power Loss, Fire Pump Phase Reversal and Fire Pump Power Transfer.

Near the time of project commissioning, the owner will furnish and install suitable communications and interface devices to ensure points are monitored at SCC. The Project Managers shall ensure that the cost of the interface devices and associated labor are included in the base budget for all new construction. The transceiver shall be located next to the building main fire alarm control panel. Additional work may include running a conduit from transceiver to an antenna on exterior wall or roof for wireless signal. Project Manager should consult with the Fire-and-Life-Safety Manager as early in the process as possible to determine the appropriate level of monitoring for the project and to determine if there may be any problems in establishing communication with the facility.

University remote facilities, not in Charlottesville, without a constantly attended monitoring center shall have a contract in place with a company that provides services to meet the definition of listed Remote Supervising Station Service in accordance with NFPA 72. The services shall include runner service to the facility. Equipment installation, inspection, testing and maintenance are the responsibility of University.

7.6.2.6.5.2 Installation Requirements

All fire alarm wiring shall be installed in conduit. Junction box covers shall be painted red with letters "F/A" using a permanent marker on the cover.

Fire alarm signaling line and notification appliance circuits shall not be electrically loaded beyond 80% of full capacity to allow for future expansion of the system.

All fire alarm initiating devices, control modules, speaker, horn, and strobe circuits shall be labeled to identify the device address, circuit origin and function, as applicable on the device.

Auxiliary devices that are interfaced with the fire system (such as magnetic door hardware, security interfaces, BAS, sound systems, and lighting) shall have their own dedicated power source and shall not be powered by the fire alarm system.

Provide a listed addressable relay for fire alarm shutdown status for any mechanical equipment requiring duct smoke detectors.

When fire/smoke dampers are connected to the building fire alarm system and the damper load exceeds the fire alarm system relay ratings, auxiliary (NON FIRE ALARM) relays shall be provided to control line voltage for each damper on a circuit. Auxiliary relays shall be rated to support the damper load.

Spare parts shall be provided for each type of initiating, field control module and notification devices installed on the fire alarm system. A minimum of three of each type of device, or 5% of the total number of each type of device installed in the building, whichever is greater, shall be provided to the Project Manager.

Smoke detectors must be non-ionizing radiation brands or if ionizing radiation, then they must be domestic (USA).

Termination connections, other than terminals provided on devices affixed to the box, shall not be made in a junction or termination box smaller than 6"x6"x3", or the equivalent volume. Termination box covers shall be labeled. Connections shall be made using terminal strips or wire nuts.

7.6.2.6.5.3 Project Closeout and Inspections

The final version or revision of all intelligent fire alarm control panel software shall be turned over to the Project Manager for the University's Fire Protection Supervisor in addition to the record of completion form in an electronic media format such as a CD or USB Flash Drive.

1. All fire alarm initiating devices shall be labeled with the device address.
2. All notification devices shall be labeled with a distinct 6-digit number ("XXX-XXX").
3. All fire alarm initiating, notification, and auxiliary devices either added or deleted from a fire alarm system, shall be captured on a Fire System Device Inventory form and submitted to fireprotection@virginia.edu prior to occupancy.

Fire alarm systems are to be acceptance tested in accord to Code requirements. UVA Fire Protection Group shall observe the installed system and witness the fire alarm system performance tests prior to University Building Official office and responsible State Fire Marshal Office. The A/E and contractor shall certify that the fire alarm system is complete.

See 1.4.3.5 Electronic Access Controls.

7.6.2.7 OTHER SPECIAL SYSTEMS

Other special systems such as nurse call, intercom, audio/visual or paging shall be provided on a project-by-project basis.

UVA Health nurse call and patient care shower electrical boxes shall be installed such that:

1. Patient shower pull station electrical boxes to be installed on the same wall as and to the left of the showerhead at 6'-6" to the center of the box.
2. Color touch screen VOIP annunciator, single or dual patient stations, staff or duty stations and intercom recommended equipment is RACO 942 with 822 cover (8" x 4" x 2-½" box with 3-gang plaster ring).
3. Color touch screen VOIP console, code blue, shower pull station, toilet pull station, dome light, card reader, and push-to-open recommended equipment is RACO 231 with 782 cover (4" x 4" box with 1-gang ring).
4. Where a single manufacturer is identified, University Project Manager shall verify conformance with state procurement regulations.

7.6.2.8 EMERGENCY GENERATORS & OTHER FUEL BURNING EQUIPMENT

All fuel burning equipment requires evaluation for inclusion in the University of Virginia Federal Title V Air Permit and for permitting as a new stationary source (9VAC5-80). The Project Manager is to provide the Associate Director for Environmental Resources with the following information to facilitate the environmental review and permit applications:

1. Copy of the manufacturer's specifications
2. Copy of any available emissions data from the manufacturer
3. Size/capacity (kW, hp or btu/hr)
4. Manufacturer, model number and serial number
5. Fuel type
6. Fuel tank specifications
7. Generator/boiler and tank location
8. Installation completion date

The manufacturer's specifications must be provided for each new piece of fuel burning equipment before they are purchased. Environmental Resources shall be notified of any removal, replacement or modifications of any fuel burning equipment in order to maintain the University's permit documentation accordingly.

The Contractor shall submit the emissions certificate from the manufacturer documenting the air emissions performance.

Generator fuel shall be ultra-low sulfur diesel (max sulfur of 15 ppm) and shall meet regulatory requirements. A fuel certification shall be provided by the Contractor and include:

1. Name of supplier
2. Date of fuel received
3. Volume of fuel delivered in shipment
4. Statement that oil complies with ASTM specs for No. 2 fuel oil
5. Sulfur content of oil and method used to determine sulfur content

Exhaust stacks shall be installed so as to not cause or contribute to a condition of air pollution back into the building of interest or adjacent sensitive locations (e.g., stack height is 10 feet above rooftop, vertical discharge, avoiding discharge into nearby outside air intakes or windows). Generators shall not be installed on roofs.

Provide cam locks on the load side of the generator breaker for the purpose of load bank testing and temporary generator installation in the event of a generator failure. Provide 2 #14 AWG conductors from the transfer switch to the generator to enable a contact to disconnect the load bank if building power is interrupted during load bank testing. Provide a hard-wired interface from the generator to the UVA BAS system to monitor the following points (at a minimum): generator general alarm, generator fuel tank level, and automatic transfer switch (ATS) position

Professional designers under contract to the University for a specific project are responsible for compliance with all legislated requirements.

7.6.3 ELECTRICAL TESTING

All electrical systems shall be tested prior to acceptance. All testing shall be in accordance with the International Electrical Testing Association (NETA) Acceptance Testing Specifications, manufacturer's recommendations or other approved testing standards. An independent testing company shall perform testing. Contractor shall notify the testing agency when the systems are ready for testing. Copies of test reports and any recommendations shall be furnished to the Project Manager. Facilities Management shall be notified in advance of testing and shall have the option of witnessing any or all tests.

All testing of electrical systems of a capacity of greater than 30 kW must be coordinated at least two working days in advance with the Facilities Management Department of Operations or the UVA Health Physical Plant, as appropriate and coordinated by the Construction Administration Manager. Testing may be required to be performed during off-hours.

7.6.4 RECORD OR AS-BUILT DOCUMENTS

At a minimum, electrical as-built documents shall contain the following information:

1. Location of all underground electric lines, telephone lines, manholes, pull boxes, etc.
2. Location of all conduits in and/or under slab
3. Location of all device boxes in slab
4. Location/routing of all conduits greater than 1" and any associated pull boxes
5. Location of all transformers, panelboards, switchgear, etc.
6. Final one-line and/or riser diagram to include the final fuse sizes
7. Final circuit numbers for all devices and final panel schedules
8. Final manufacturer and make for all fixture types
9. Exterior lighting information as detailed in *4.12.1 Site Lighting*.
10. Final location of all exit and emergency lighting
11. Final locations of all fire alarm devices, terminal cabinets, etc.
12. Final locations of all telephone, and other low voltage system backboards
13. Final locations of all lighting control devices
14. HVAC zone maps by air-handling unit that clearly indicated which areas of the building are served by each air-handling unit.

See *1.5.3 Operation and Maintenance Manuals/Data*.

7.7 ELECTRONIC MONITORING AND CONTROLS

7.7.1 APPLICATION

All building automation system controls shall be specified in Division 25. Only building automation system technologies natively from one of UVA's preapproved building automation system vendors shall be used. Any packaged equipment to be integrated into the BAS for monitoring shall be native BACnet and reviewed and approved by Automation Services prior to purchase.

Systems that require remote monitoring and/or control, utilizing the existing approved computerized central systems, include, but are not limited to: (1) HVAC, (2) fuel burning equipment, and (3) emergency generators.

The extent and nature of controls and/or monitoring systems shall be determined and submitted for approval in the Preliminary Design phase of the project. The use of stand-alone electric controls requires an approved D&F. See Appendix B: Utility Metering Requirements and Chapter 8: Green Building Standards for sub-metering. All non-electric meters shall be owner furnished and contractor installed (OFI). Electric meters shall be contractor furnished and contractor installed.

7.7.1.1 GENERAL GUIDELINES

1. Controls system design and installation shall be in accordance with UVA BAS Standards documents.
2. The vendor of electronic monitoring and controls shall provide all control devices.
3. All controls shall be DDC and all actuation shall be electric.
4. A five-year warranty shall be specified on electric actuators.
5. During renovations all pneumatics in the area being renovated shall be replaced with DDC and electric actuation.
6. Individual offices shall have means of ensuring acceptable temperature control (user adjustable thermostat and control device, appropriate zoning or other designed means). Where air terminal devices serve multiple offices provide a temperature sensor in each office, averaged to control the air terminal device.
7. Provide Magnehelic gage or inclined manometer on all air filters for systems over 2,000 CFM.
8. The air tubing on VAV boxes shall be neoprene rather than rubber or plastic.
9. All dual technology lighting control occupancy sensors shall be capable of integration into the University's HVAC control system via integral auxiliary contact (not through BACnet network integration).
10. Controls such as carbon dioxide (CO₂) or occupancy sensors shall be used to modulate outside airflow in densely occupied spaces (40 square feet per person or less), including offices, classrooms, lecture halls, break rooms, conference and meeting rooms, lobbies, and multipurpose spaces. On units with CO₂ control, the sequence of operation shall specify the maximum CO₂ PPM concentration and the maximum and minimum airflow setpoints.
11. Controls such as occupancy sensors shall be used to modulate outside airflow in listed non-densely occupied spaces - offices, break rooms, and small meeting rooms. On units with occupancy sensor control, the sequence of operation shall specify the maximum and minimum airflow setpoints.
12. Units with CO₂ controls will be shut off during unoccupied hours when CO₂, temp, and relative humidity are satisfied; and restarted on demand by any of those sensors. When all classrooms on a given system are empty during normal occupied hours, the outside air damper shall not close but shall go to a minimum position as required by code, and the CO₂

level will be allowed to fluctuate. If extreme conditions prevent the system from maintaining all set points, the CO2 level will be allowed to drift. The BAS will monitor points as required to detect failure to maintain any set point.

13. Untempered outside air shall not be supplied directly to occupied spaces.
14. Sequence will specify if fans run continuously or can be shut off. Supply, return, and exhaust fans shall be interlocked as required.
15. AHUs should have manual override to run unit with high outside airflow (for venting odors from new carpet/furniture, floods, etc.)
16. Where perimeter heat is needed at large windows and exterior walls, it shall be interlocked with AHU/zone control. Perimeter heat will normally be supplied from a building LTHW loop.
17. Freeze protection shall be provided on all HVAC equipment with an OA connection. Freezestats shall stop the supply and return fans, close the outside damper, and open the heating coil valve directly, without relying on any controller or controls logic programming. Where DDC is used, the freezestat controls shall be completely independent of the DDC system. Where freezestats are impractical or not possible (e.g. small fan coil units), freeze protection via alternative means (analog temp sensor w/logic, etc) may be implemented with UVA Automation Services written approval. For FCUs supplied with unconditioned OA, OA connection point shall be not less than 5 linear feet and one change in direction from coil face to facilitate adequate mixing of RA and OA air streams.
18. Beginning with the preliminary design submission, provide HVAC zone maps by AHU that clearly indicate which areas of the building are served by each unit. For Labs/HSPP buildings, provide HVAC Zone maps for return/exhaust systems as well.

7.7.1.2 CRITICAL LOADS

In buildings with critical loads, as determined by Facilities Management, all necessary components of the HVAC, control and communications systems shall be on emergency power

Critical safeties on HVAC systems shall be hard wired rather than controlled by the DDC system. All safeties shall include a minimum of two sets of integrated contacts to facilitate operation of unit safety circuit and simultaneous monitoring by the DDC system. Use of external relays as additional contacts is not acceptable.

Critical exhaust fans (Vivarium, BSL suites, rad hoods, perchloric acid hoods, etc.) that run continuously should not have a start/stop function on the DDC system. Provide a manual hand/off/auto switch and failure alarm to the DDC. Where two fans are provided the “lead” fan will be in the “hand” position and the “lag” fan will be in the “auto” position so the DDC system can start the “lag” fan automatically upon a failure of the “lead” fan.

7.7.1.3 SENSORS

Building automation system (BAS) sensors used for energy monitoring shall be provided with thermal energy packages per Appendix B: Utility Metering Requirements. Outside air conditions shall be obtained via the network sensor at the Leake building, with the primary failsafe being the networked BACnet weather station. Facilities with critical functions dependent on OAC may use a local weather station as its primary sensor, as approved by Automation Services and the Office of the University Architect.

7.7.1.4 SMOKE DETECTORS

Where the fire alarm is required to interlock with HVAC equipment, the fire alarm system shall provide a minimum of two sets of dry contacts for BAS monitoring and hardwired equipment

interlocks. These contacts may be provisioned in the form of integrated smoke detector contacts or approved remote relay devices native to the fire system. Additional contacts may be required, depending on equipment configuration and interlock requirements.

7.7.1.5 ANIMAL HOLDING ROOMS

Provide temperature and humidity display for each animal holding room. Displays shall be NIST traceable, with NEMA type enclosures. If displays are located inside the animal rooms they shall have a waterproof enclosure suitable for periodic wash downs. The sensors for these displays shall be the controlling sensors and should be suitable for high humidity environments with quick recovery for saturation events. If the humidifier is provided in the central station AHU, the humidity sensors shall be averaged for control.

7.7.1.6 BSL-3 LABS

BSL-3 labs shall have a means to completely shut off the supply air if exhaust air is lost to prevent a positive pressure in the space; this shall be via a hardwired connection, NOT through the DDC system. Bubble or gas tight dampers on the supply air may be appropriate in some situations.

A central UPS system or a number of local UPS systems should be used to back-up all building-wide low voltage systems that are essential for BSL-3 containment operation as well as critical research, patient care and other critical systems.

7.7.2 BIDDING PROCEDURES

The Project Manager shall solicit pricing proposals from UVA prequalified control system vendors as part of the primary project bid documents. As an alternative, the A/E and Project Manager, through the Facilities Planning and Construction Office of Contract Administration, may provide drawings and specifications to providers of approved BAS systems and negotiate pricing separately from the primary project bid documents. The selected BAS supplier shall be contracted and the primary project bid documents shall include assignment of this negotiated price to all bidders.

7.7.3 CONTRACT DOCUMENT GUIDELINES

The UVA Building Automation System Standards shall be included in the Contract Documents or incorporated by reference stating that the Controls Contractor must adhere to the latest version of the BAS Standards. Sequence of operations shall be per UVA Standard Control Sequences. Unless otherwise agreed in consultation with UVA the A/E will include in the Contract Documents the Building Automation System Guidelines (incorporate in Section 25 0000 of the Specifications) linked on the OUBO website (<https://oubo.virginia.edu/udg.html>).

The A/E shall also incorporate the following in the Contract Documents:

1. Sequence of operations shall be noted on the control drawings. Specification shall require the Contractor to permanently mount a copy near the equipment.
2. AHU points list, airflow schematic, and sequence of operations shall be on the same sheet. AHU schedule (with gallons per minute) and detail shall also be on this same sheet, unless space prohibits.
3. Pumps point list, pump flow diagram and sequence of operations shall be on the same sheet. Pump schedule and detail shall be on this same sheet, unless space prohibits.
4. Building plans shall include chilled water, hot water/steam and airflow schematics. Designs

- for renovation projects shall update existing building schematics.
5. Provide a component coordination responsibility matrix specifying the HVAC, ATC and Electrical Contractor's scope of work for devices furnished, installed or wired by different divisions of specifications. The matrix should include the following headings: Device, Furnished By, Installed By, Power By, Control Wiring By, and Fire Alarm Wiring By.
 6. BAS control power to be shown on electrical power plans at each equipment location terminating at a junction and indicating circuiting. Controls shall be provided with dedicated circuits, separate of equipment power, except for powered terminal equipment such as fan coil units and unit heaters. Where controlled equipment is powered from an emergency power source associated control power circuit and all BAS infrastructure upstream of controller shall also be powered from an emergency power source. Power for controls shall not be from adjacent lighting or receptacles. Control circuits shall serve no more than 30 terminal units and be readily identified on panel schedules. Centralized low voltage transformers/power supplies for distributed terminal units shall not be used except where approved by UVA Automation Services.

Prior to beneficial occupancy, BAS Closeout Procedure shall be complete and reviewed by Systems Control Center and Automation Services. Project database and graphics shall merged into UVA's Production Database for control, monitoring, and alarm response by System Control Center. The warranty period on all equipment will begin only after system acceptance by the University.

Chapter 8 Green Building Standards

The University of Virginia Green Building Standards outline UVA's minimum expectations for aligning University-wide sustainability goals with building design, construction, and maintenance. Each specification has one or more of the following goals: reduce environmental impact, reduce anticipated life cycle costs, and/or promote healthier and safer buildings. Additional resources can be found at the UVA Office for Sustainability website.

The Green Building Standards section 8.1 applies to all projects (any project requiring a building or project permit), within the project's scope of work. Supplemental standards for new construction and major renovations for which LEED certification is already a minimum requirement are included in Section 8.2. New construction and major renovation projects should begin coordination with UVA Office for Sustainability (sustainability@virginia.edu) as early as possible and no later than the Schematic Design stage.

8.1 GENERAL REQUIREMENTS FOR ALL PROJECTS

The following requirements apply to all project (any project requiring a building or project permit).

8.1.1 ENERGY

The following requirements focus on building energy consumption.

8.1.1.1 HVAC

1. Equipment rooms (lab equipment rooms, autoclave rooms), server rooms, mechanical/electrical rooms, and all other spaces with a high heat load shall be separately zoned and provided with dedicated cooling. Cooling system shall be connected to central chilled water where feasible. Verify chilled water is available year-round.
2. Provide airside economizers for all air handling systems with a cooling capacity equal to or greater than 54,000 Btu/h. The system shall be capable of modulating outdoor air and return air dampers to provide up to 100% of the design supply air quantity as outdoor air for cooling.
3. The maximum allowable fan system power shall be ten percent (10%) less than the requirements outlined in latest edition of ASHRAE Standard 90.1 (Table 6.5.3.1-1) for each fan system. Document compliance using Table 8.1.1.6.4 or similar (e.g., COMcheck compliance form).
4. Provide energy recovery for outside air systems per the most recent version of the Virginia Energy Conservation Code section C403.7.4. Any exceptions shall be reviewed by UVA and accompanied by a life cycle cost analysis.
5. All heating water strainers, control valves, and balancing valves, including 1" and smaller, shall be insulated in accordance with Table C403.2.10 Minimum Pipe Insulation Thickness of the current version of the Virginia Energy Conservation Code.
6. Intermittent local exhaust & make up air systems (such as kitchen hoods, paint spray booths, etc.) shall be switched. Demand control ventilation is preferred in commercial kitchen applications.
7. During equipment replacement, consider opportunities to right-size equipment based on updated calculations and assumptions.

8. Preference shall be given to refrigerants of low global warming potential (GWP) as outlined in the Kigali Amendment to the Montreal Protocol.

8.1.1.2 LIGHTING

1. Lighting power densities (LPD) for each space type shall be no greater than the 'Space-by-Space' allowances and/or the 'Building Exteriors' allowances provided in latest edition of ASHRAE Standard 90.1. Document compliance using Table 8.1.1.6.3 or similar.
2. Exterior lighting required for safety and security (including egress) shall be on whenever the exterior is dark. Site and exterior architectural accent lighting should be on a different schedule so it can be shut off during certain hours (default off between midnight and 5 AM). Site and exterior architectural accent lighting shall be on separate control circuits, controlled via an astronomical schedule or on a photocell with a schedule override.
3. Provide high trim for all dimmable lighting via the lighting control system.
4. Local, non-network lighting control systems are preferred to networked lighting control systems. Coordinate with UVA Automation Services and UVA FM Technology & Innovation (fm-ti-systems@virginia.edu) wherever network systems are pursued.
5. Existing non-LED light fixtures within the project scope shall not be reused.
6. Projection should be designed to minimize light pollution. Refer to sections 4.12.1 Site Lighting and 8.2.2.2.6 Prescriptive Requirements for more information.
7. Lighting characteristics and controls shall comply with the following lighting properties table.

FIGURE A - UVA LIGHTING PROPERTIES TABLE

Space Type	Task Lighting	Vacancy Control (Manual On / Auto Off) ¹	Occupancy Control (Auto On / Auto Off) ¹	Other Control Requirements	Default Shutoff Time
Lecture, Training, Classroom	No	Yes	n/a	Dimming, High End Trim ² , Classroom Standard Package ³ , Daylight Harvesting ⁴	30 minutes
Conference, Meeting, Multipurpose Room	No	Yes	n/a	Dimming, High End Trim ²	30 minutes
Laboratory - Teaching, Research	Yes	Yes	n/a	Dimming, High End Trim ² , Daylight Harvesting ⁴	30 minutes
Lobby	No	n/a	Yes	Dimming, High End Trim ² , Daylight Harvesting ⁴	30 minutes
Offices - Private	Yes	Yes	n/a	Dimming, High End Trim ²	30 minutes
Offices - Open Plan	Yes	Yes	n/a	Dimming, High End Trim ² , Daylight Harvesting ⁴	30 minutes
Dining Area	No	Yes	n/a	Dimming, High End Trim ² , Daylight Harvesting ⁴	30 minutes
Dormitory Living Quarters	Yes	n/a	n/a	Manual Switch	n/a
Restroom	n/a	n/a	Yes	n/a	30 minutes
Corridor	n/a	n/a	Yes	n/a	30 minutes
Stairwell	n/a	n/a	Yes	High / Low Control (100% high output / 1 fc low output)	30 minutes
Storage	No	Yes	n/a	n/a	30 minutes
Telecom Room, Closet	No	Yes	n/a	n/a	30 minutes
Electrical, Mechanical Room	No	n/a	n/a	Timed Switch	12 hours
Parking Garage: Garage Area	n/a	n/a	Yes	High / Low Control (100% high output / 20% low output)	15 minutes
Exterior Architectural Lighting	n/a	n/a	n/a	Time of Day Schedule (Off Midnight to 5am)	n/a
Exterior Egress Lighting (walkways, steps, ramps, parking)	n/a	n/a	n/a	Photocell	n/a

¹ Dual technology motion sensor required (i.e., infrared + acoustic).

² High end trimming shall be set to 100% of design illuminance (foot-candles) and set via building lighting controls.

³ Coordinate with ITS-Classroom Support for lighting and AV requirements (crdesign@virginia.edu).

⁴ Daylight harvesting recommended for all projects, but only required for capital projects or where required by code.

8.1.1.3 FOSSIL FUEL FREE DESIGN

In light of UVA's articulated fossil free fuel goal, the on-site combustion of fuels shall be prohibited unless required for life safety and emergency back-up systems. Space heating, water heating, cooking, and humidification applications shall all be provided via district heating or electricity-based equipment.

8.1.1.4 EQUIPMENT

1. All new equipment shall be certified energy and water efficient where available. Preferred certifications include Energy Star, WaterSense, EPEAT, ACT and/or CEE Tier 2 certified. Applicable equipment includes laboratory and kitchen equipment (e.g., refrigerators, freezers, autoclaves, washers, ovens, etc.), office equipment (e.g., monitors, printers, multifunction devices, etc.), and AV/IT equipment (e.g., televisions, projectors, video walls, servers, network devices, etc.).
2. All large video displays (e.g., video walls, projectors) shall be designed to minimize energy consumption and include features to automatically turn off the display during unoccupied hours. Displays larger than 100 inches diagonal and 300 watts shall include a 30-year life cycle cost analysis (including estimates of annual energy consumption, service life, maintenance, repair, and replacement costs).

8.1.1.5 BUILDING ENVELOPE

1. All new windows and skylights shall have thermally broken frames. Single pane windows within the project scope shall be evaluated for replacement unless historic considerations limit window upgrades. Document compliance using Table 8.1.1.6.2 or similar.
2. Opportunities to enhance the performance of the existing building envelope to meet the minimum envelope requirements from the most recent version of the Virginia Energy Conservation Code (e.g., Table C402.1.3) shall be considered for all areas within the project scope. Document compliance using Table 8.1.1.6.1 or similar.

8.1.1.6 ENERGY COMPLIANCE TABLES

Provide the following energy compliance summary tables for all applicable envelope, lighting, and HVAC systems at Preliminary Design and Construction Document submissions. Equivalent tables or standardized outputs (e.g., COMcheck) are also acceptable.

Table 8.1.1.6.1

OPAQUE ENVELOPE			
ASSEMBLY	DESCRIPTION	CODE	DESIGN
		R-VALUE	R-VALUE*
Assembly #1			
Assembly #2			
...			

* Design R-value shall be effective R-value and include the effects of thermal bridging

Table 8.1.1.6.2

FENESTRATION						
ASSEMBLY	ORIENTATION	CODE		DESIGN		
		U-FACTOR	SHGC	U-FACTOR*	SHGC	VLT
Assembly #1						
Assembly #2						
...						

* Design U-factor shall represent full assembly, not center-of-glass

Table 8.1.1.6.3

LIGHTING POWER DENSITY				
SPACE	REQUIREMENT*	DESIGN		
	W / SF	WATTS	AREA (SF)	W / SF
Space type #1				
Space type #2				
...				

* See table in Section 8.1.1.2: Lighting

Table 8.1.1.6.4

FAN SYSTEM POWER			
SYSTEM	CONSTANT OR VARIABLE VOLUME?	FAN POWER LIMITATIONS*	DESIGN**
		HP OR BHP	HP OR BHP
System #1			
System #2			
... etc			

* See VECC Table C403.8.1

** No greater than 90% of Fan Power Limit

8.1.2 INDOOR ENVIRONMENTAL QUALITY

The following requirements focus on improving the health and wellbeing of building occupants.

8.1.2.1 FILTRATION

1. Provide a minimum 12" MERV 13 filter for (a) all dedicated outside air units and (b) all other air handling units with an air volume greater than 2,500 CFM. In UVA Health facilities, provide a MERV 14/14A filter at minimum and comply with ASHRAE 170, where applicable. For systems less than 2,500 CFM, a 4" filter rack is preferred.
2. A separate pre-filter directly upstream of a 12" filter is not required. However, pre-filters are encouraged in systems with 2" or 4" filters.

8.1.2.2 ACOUSTICS

1. The Project Manager shall direct questions regarding noise generating equipment and processes or spaces requiring unique acoustical requirements to the University's Office of Environmental Health and Safety. When placing noise-generating equipment, the A/E shall consider uses of surrounding spaces that may dictate sound levels lower than typical spaces.
2. HVAC systems noise levels shall meet Noise Criteria and dBA sound pressure levels specified per the latest edition of the ASHRAE HVAC Applications Handbook, Chapter 49 Noise and Vibration Control.
3. Duct lining is the preferred method of acoustical treatment. Sound attenuators shall be used only in cases where acoustic duct lining is insufficient to meet design requirements. In cases where sound attenuators will be used, their pressure drop at design condition shall be no greater than the smaller of 0.15 in. w.g. or the allowable fan power pressure drop adjustment in the current version of the Virginia Energy Conservation Code (Section C403.2.12).

8.1.2.3 HUMIDIFICATION AND DEHUMIDIFICATION

1. Humidification shall not be provided unless required by code or as dictated by unique programmatic requirements. If deemed necessary, evaluate whether humidification should be provided at the air handling unit level or via decentralized systems. All water for humidification shall be reverse osmosis water.
2. A system capable of maintaining a maximum allowable dewpoint of 60F shall be provided. If dewpoint control is not available, the system shall maintain a maximum allowable relative humidity of 60%. In healthcare facilities and other applicable spaces, compliance with ASHRAE 170 shall take precedence.
3. Systems incorporating chilled beams or other radiant space cooling devices shall maintain a maximum allowable dewpoint in those spaces that is 2F below the supply water temperature to those devices.

8.1.2.4 VENTILATION

1. No outside air shall be provided to spaces during scheduled unoccupied times. If an occupancy sensor determines the space is vacant during scheduled occupied times, the outside air shall be set to the minimum allowed by code. During scheduled unoccupied times, if occupancy is sensed either by an occupancy sensor or by manual override of a temperature sensor, the requisite outside air shall be provided until the space returns to an unoccupied state.
2. New projects introducing natural ventilation or operable windows to a space shall provide window interlocks or some other means of sensing open windows that disables HVAC to the

space while natural ventilation is being provided or windows are open. Natural ventilation shall not be considered an energy savings strategy unless it is automated.

8.1.2.5 CONSTRUCTION

Meet or exceed all applicable recommended control measures of the Sheet Metal and Air Conditioning National Contractors Association (SMACNA) IAQ Guidelines for Occupied Buildings under Construction (aligned with LEED v4.1 credit - Construction Indoor Air Quality Management Plan).

8.1.3 MATERIALS AND WASTE MANAGEMENT

The following requirements focus on providing building materials that are safe for contractors, maintenance staff, and building occupants and provide guidance toward proper disposal of trash and recycling.

8.1.3.1 LOW EMMITTING INTERIOR MATERIALS

1. Meet the following requirements as outlined in the LEED v4.1 EQ Credit: Low-Emitting Materials:
 - a. All paints and coatings wet-applied on site must meet the applicable volatile organic compound (VOC) limits outlined in the LEED v4.1 EQ Credit: Low Emitting Materials (e.g., SCAQMD Rule 1113).
 - b. All adhesives and sealants wet-applied on site must meet the applicable VOC limits outlined in the LEED v4.1 EQ Credit: Low Emitting Materials (e.g., SCAQMD Rule 1168).
 - c. All new furniture and furnishing items must meet the applicable VOC limits outlined in the LEED v4.1 EQ Credit: Low Emitting Materials (e.g., ANSI/BIFMA e3-2014e).
 - d. No composite wood with added formaldehyde shall be used.
 - e. Products achieving GreenGuard Gold certification meet the intent of these requirements.
2. Additional Requirements:
 - a. No insulation for walls, ducts and piping with added formaldehyde shall be used. Insulation achieving GreenGuard Gold certification meets the intent of this requirement.

8.1.3.2 WASTE MANAGEMENT DURING CONSTRUCTION

1. Coordinate with UVA Recycling for dropoff of recyclable materials.
2. Coordinate with UVA ReUSE Store to dispose of usable furniture, equipment, and building supplies.
3. Construction and demolition debris separation on site is encouraged. Use a material recovery facility for remaining waste. Preference shall be given to material recovery facilities that provide waste diversion rates verified by a third party such as the Recycling Certification Institute.

8.1.3.3 WASTE INFRASTRUCTURE

1. All projects shall comply with UVA's Waste Infrastructure Design Requirements, linked on the OUBO website (<https://oubo.virginia.edu/udg.html>).
2. For all capital projects, a kick-off meeting including the custodial vendor, UVA Recycling and

the Office for Sustainability (OFS) is required as early as possible to inform development of the schematic design.

3. For non-capital projects where space is reconfigured, the UVA PM shall send initial schematic design drawings with waste service areas and waste stations clearly identified to the custodial vendor, UVA Recycling (recycling@virginia.edu) and OFS (greenbuilding@virginia.edu) as early as possible to inform development of the schematic design.
4. Outdoor trash and recycling containers shall be Owner furnished and Owner installed (OFOI). Indoor trash and recycling containers and associated signage shall be Owner furnished and Contractor installed (OFCI).

8.1.4 WATER

The following requirements focus on improving water consumption and the efficiency of domestic water heating and delivery systems.

8.1.4.1 DOMESTIC HOT WATER

Lavatory piping systems shall be designed to deliver hot water within 10 seconds.

8.1.4.2 FIXTURES

New plumbing fixtures shall meet the following fixture requirements.

FIXTURE TYPE	REQUIREMENT
Faucets - Public Bathrooms	0.5 gallons per minute (GPM)
Faucets – Private or Residential Bathrooms	0.5 GPM
Faucets – Patient Care	1.5 GPM with no aerators
Faucets - Laboratories	1.5 GPM
Faucets - Teaching Laboratories	1.0 GPM
Faucets - Kitchenettes / Breakrooms	1.5 GPM
Water Closets - Patient Care	1.6 gallons per flush (GPF)
Water Closets - Residence Halls	Dual Flush: 1.1/1.6 GPF and WaterSense labeled
Water Closets - All Other	1.28 GPF and WaterSense labeled
Urinals - Patient Care	0.5 GPF and WaterSense labeled
Urinals - All Other	0.125 GPF and WaterSense labeled
Showerheads	1.8 GPM; verify pressure to provide adequate flow
Water Fountains and Bottle Fill Stations	Energy Star certified
Washing Machines	Energy Star certified
Ice Makers *	Energy Star certified
Dishwashers *	Energy Star certified
Refrigerators and Freezers *	Energy Star certified
All other water consuming fixtures and equipment not listed (i.e. lab equipment, commercial kitchen equipment, etc.) shall be selected to be water and energy efficient. All equipment shall be submitted for review to the University of Virginia.	

*For equipment in healthcare facilities, coordinate with HSPP to ensure special provisions related to infection control are considered (e.g., no ice melt recapture).

8.1.5 SITE & LANDSCAPE

The following requirements apply to any projects with exterior site scope:

8.1.5.1 IRRIGATION

1. Design landscapes to not require permanent irrigation systems, especially those using potable water. Specify plantings that do not require irrigation after establishment.
2. If irrigation is necessary, such as on an intensive green roof or an athletic field, use non-potable water sources such as condensate or rainwater capture wherever feasible. Potable water may be used for temporary irrigation during plant establishment period.
3. If irrigation is necessary, design irrigation systems for minimum water use using high-efficiency equipment with moisture sensing capabilities, contingent upon approval of a Determinations and Findings waiver to use potable water.

8.1.5.2 PLANTINGS

1. Develop design intent and plantings in accordance with UVA Landscape Typologies and Standards. Coordinate with Landscape Services and Office of the Architect.
2. Use vegetation to reduce urban heat island effect and minimize building energy use. Specify and locate trees to shade paved areas, especially dark surfaces such as asphalt and brick. Specify vegetation such as green roofs, green walls, and shade trees to reduce building energy consumption.

8.1.5.3 TRANSIT AND MICROMOBILITY

1. Coordinate with UVA Parking & Transportation during the schematic design phase to identify appropriate infrastructure that supports access to alternative transportation. Examples may include curb ramps, bus bulbs, and bus shelters, as well as storage and charging infrastructure for bicycle, micromobility, and other personal electric vehicle (PEV) users.

8.1.6 LIFE CYCLE COST

Perform ongoing life cycle cost analyses according to the following requirements:

1. Using the UVA Life Cycle Cost (LCC) Calculator, analyze major systems (e.g., envelope, HVAC, etc.) options at significant design stages (SD, PD, and CD). Coordinate with energy modeling efforts, where applicable.
2. Provide life cycle justification, including documentation of LCC metrics for all life cycle cost-based decisions.
3. When evaluating cost-saving measures (e.g., value management sessions), present operational costs in addition to first costs using the UVA Life Cycle Cost Calculator.

8.2 CAPITAL PROJECTS – NEW CONSTRUCTION AND MAJOR RENOVATIONS

This portion of the Green Building Standards applies to all capital projects. LEED certification is also a requirement for all capital projects per HECOM Section 5.1. **The prescriptive requirements in section 8.1 above also apply to these projects.**

8.2.1 PROJECT INITIATION

Set up a sustainability kickoff meeting with the UVA Office for Sustainability (sustainability@virginia.edu) as early as possible, and no later than the end of the Pre-Design / Project Initiation phase to provide the following:

1. Project-specific sustainability goals and priorities (stretch goals beyond minimum UVA and LEED requirements) via Owner’s Project Requirements (OPR) early in the planning process, prior to initiation of design. At a minimum, consider the feasibility of the following approaches in the project’s goals:
 - a. **Deep energy reductions** – a zero energy or zero carbon building
 - b. **Water reclamation** - Cooling coil condensate collection, rainwater harvesting, etc.
 - c. **Passive House certification**
 - d. **Living Building Challenge certification**
 - e. **Healthy materials focus** – including Red List free, “Red List light,” or Six Classes materials specifications.
 - f. **Embodied carbon focus** – measurement and tracking of embodied carbon and low-embodied carbon materials specifications
 - g. **EV-ready infrastructure** – including sufficient electrical capacity, spare accessible electrical panels, and conduit runs to EV-ready parking spaces
 - h. **Green healthcare initiatives** – alignment with the LEED Integrated Process for Health Promotion credit and/or the GRESB Health and Well-being Module.
 - i. **Composting infrastructure**

2. **Develop a building energy performance target** based on the UVA Building Energy Performance Requirements (summarized below). Confirm this target with the UVA Office for Sustainability as early as possible, and no later than the end of the Pre-Design / Project Initiation phase.

Building Type	UVA Maximum Building Energy Performance Requirement (kBtu / ft ² / year)
Academic	47
Residential	41
Multi-Use	51
Research	130
Inpatient	229
Outpatient	130

8.2.2 DESIGN AND CONSTRUCTION

Articulate and refine the project's sustainability goals throughout the design process. Discuss and document progress in narrative form towards goals at each major phase, including Schematic Design, Preliminary Design, and Construction Documents. Revisit goals in the post-occupancy evaluation phase and as a team. Document lessons learned. Comply with the following process and prescriptive requirements. Expectations and requirements are summarized in Green Building Standards Capital Project Checklist.

8.2.2.1 PROCESS REQUIREMENTS

1. **Follow LEED v4 Integrative Process credit requirements** (UVA prerequisite). Meetings are to include Office of the Architect, Office for Sustainability, HSPP/O&M staff, Automation Services, Environmental Health and Safety, School/Department representation (including user group), Project Manager, Architect, and Engineer. If changes occur, update the Owner Project Requirements (OPR) accordingly. Sustainability coordination meetings should occur at least as often as once per major design phase (including the Pre-Design, Schematic Design, Preliminary Design, Construction Documents, and Close-out phases).
2. **Use the UVA Life Cycle Cost Calculator** to analyze major systems options at Schematic and Preliminary Design stages. Coordinate with energy modeling efforts, where applicable. Submit results and outcomes to the UVA Office for Sustainability.
3. **Provide energy modeling as a design and decision-making tool** throughout the design process. Demonstrate that the project was designed to use the least amount of energy feasible.
 - a. Energy modeling shall begin as early as feasible in the project timeline and be regularly updated to provide design feedback and illustrate compliance with the energy use intensity (EUI) target per section 8.2.1.2. A simple box model is sufficient for pre-design stages, and a whole building energy model shall be developed no later than the Schematic Design milestone.
 - b. Energy modeling inputs and results shall be submitted in accordance with the UVA Energy Modeling and Reporting Standards and include parametric analyses for significant design alternatives (e.g., envelope construction, shading, window-to-wall ratio, mechanical systems). These results shall be shared with the UVA Office for Sustainability during each major design phase.
 - c. Perform parametric energy analyses comparing variations in window to wall ratio prior to SD submission. Include at least one design alternative with less than 40% window to wall ratio on each major elevation.
 - d. For all non-single pass air systems, provide an energy model and life cycle cost analysis of a dedicated outside air system with energy recovery and terminal heating and cooling units (e.g., chilled beams, radiant systems, fan coil units, blower coil units) compared with the proposed system.
 - e. The full, working energy model shall be provided to UVA for ownership at the completion of the project.

8.2.2.2 PRESCRIPTIVE REQUIREMENTS

1. **Solar-ready design.** Design all new low-slope roofs to be “solar-ready” including conduit to the roof, room for future inverters, confirmation that structural design is sufficient for future solar photovoltaic (PV) installation, and a rooftop equipment layout that optimizes solar access. Coordinate with UVA Energy and Utilities for engineering, procurement, and installation of solar panels. See NREL Solar Ready Buildings Planning Guide for more information about solar-ready best practices.
2. **Fossil Fuel Free Design.** On-site combustion of fuels is prohibited unless required for life safety and emergency back-up systems. Provide space heating, water heating, cooking, and humidification applications via district heating or electricity-based equipment.
3. **Construction Waste Management.** Achieve LEED v4 MR Credit: Construction and Demolition Waste Management Option 1 (Diversion). Identify significant construction and demolition waste streams for on-site separation and landfill diversion. All remaining materials shall be sent to a material recovery facility with diversion rates verified by a third party such as the Recycling Certification Institute.
4. **Commissioning.** Achieve LEED v4 EA Credit: Enhanced Commissioning Option 2 (Building Enclosure Commissioning).
5. **Bird-safe Building Design.** Achieve LEED v4.1 Innovation Credit: Bird Collision Deterrence, or similar bird-safe design standard (e.g., American Bird Conservatory best practices).
6. **Light Pollution.** Achieve LEED v4 SS Credit: Meet upright and light trespass requirements using either of the two options.

APPENDIX A – Figures

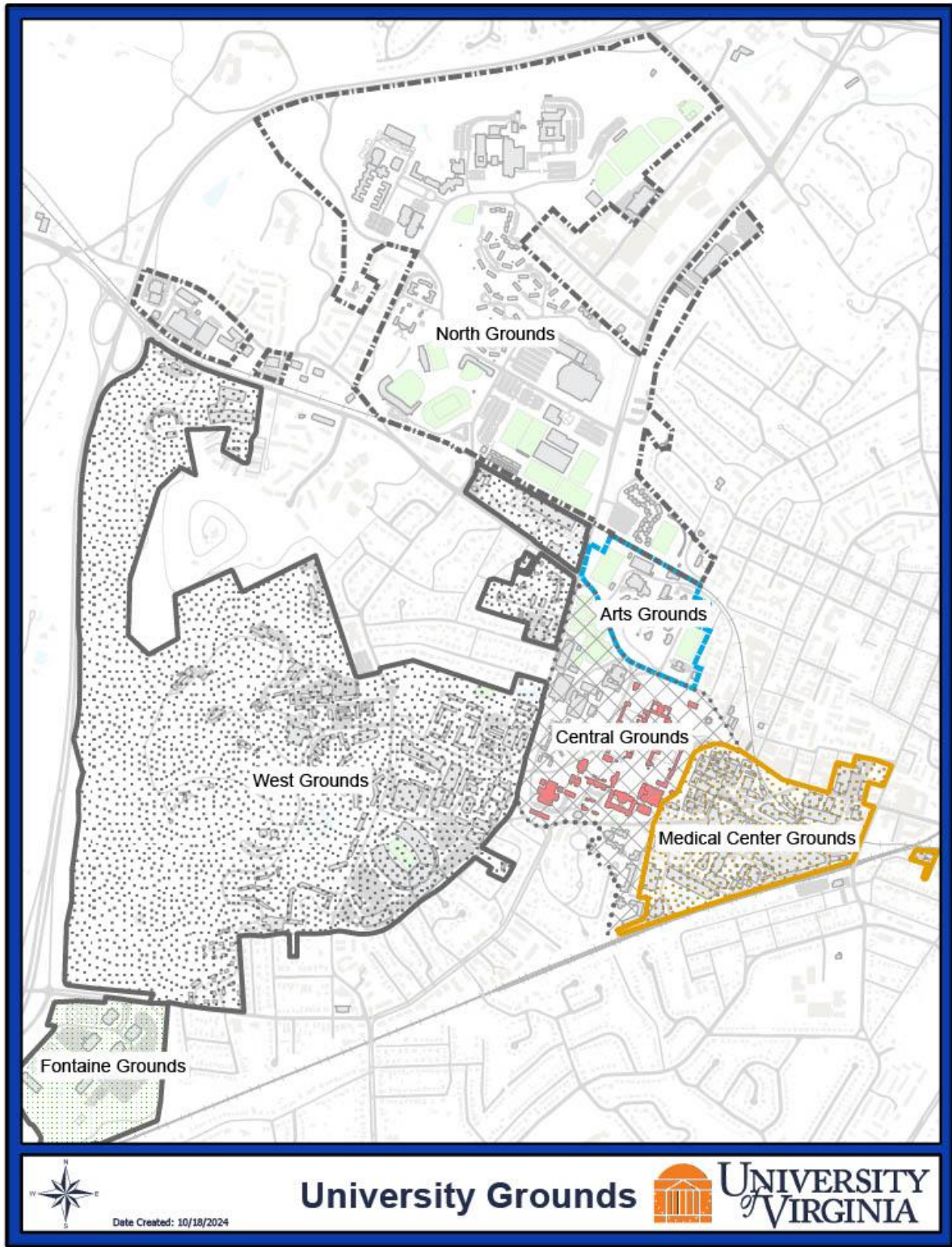

Figure 1: University Grounds

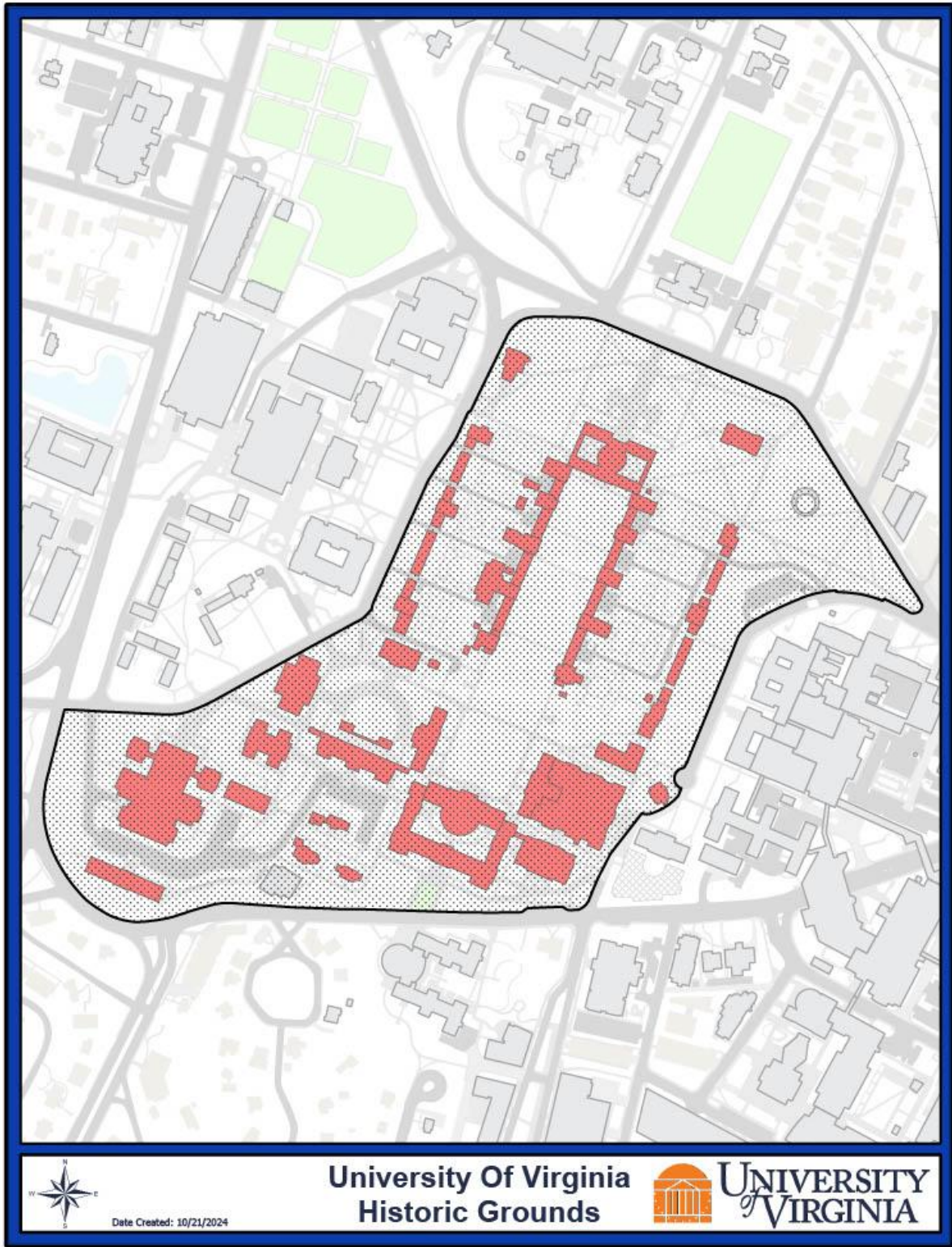

Figure 2: Historic Grounds

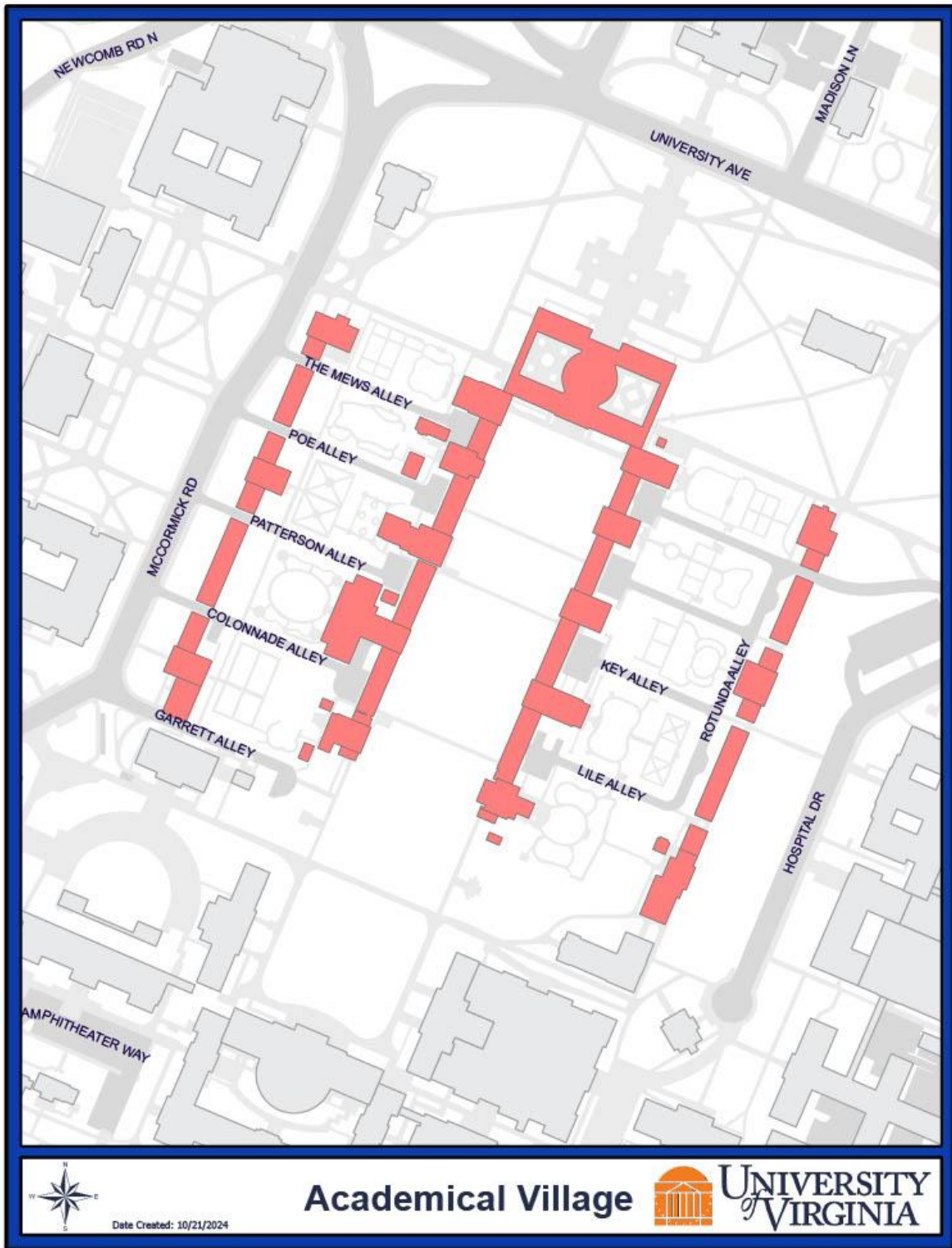

Figure 3: Academical Village

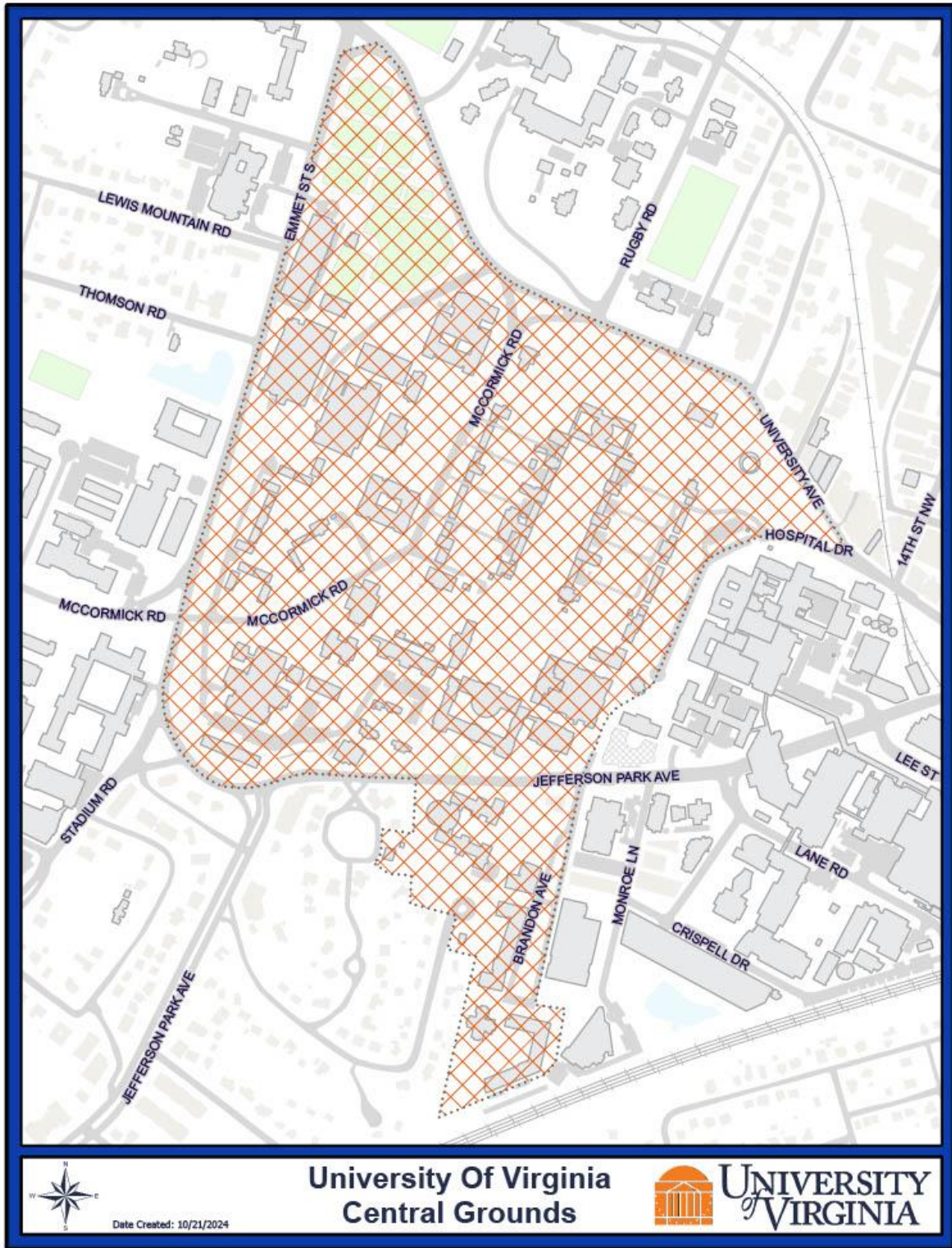
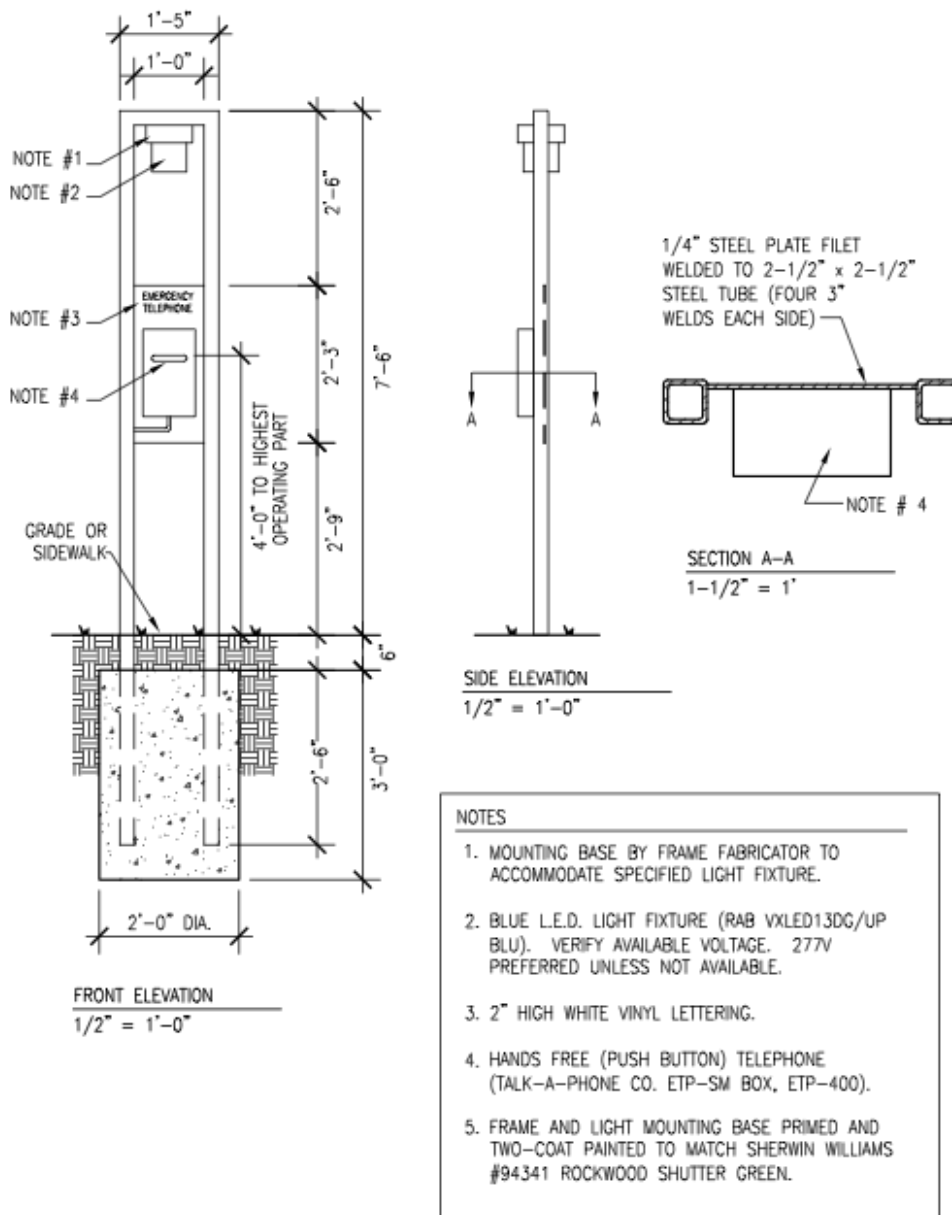

Figure 4: Central Grounds



EMERGENCY PHONES

Figure 5: Emergency Phones

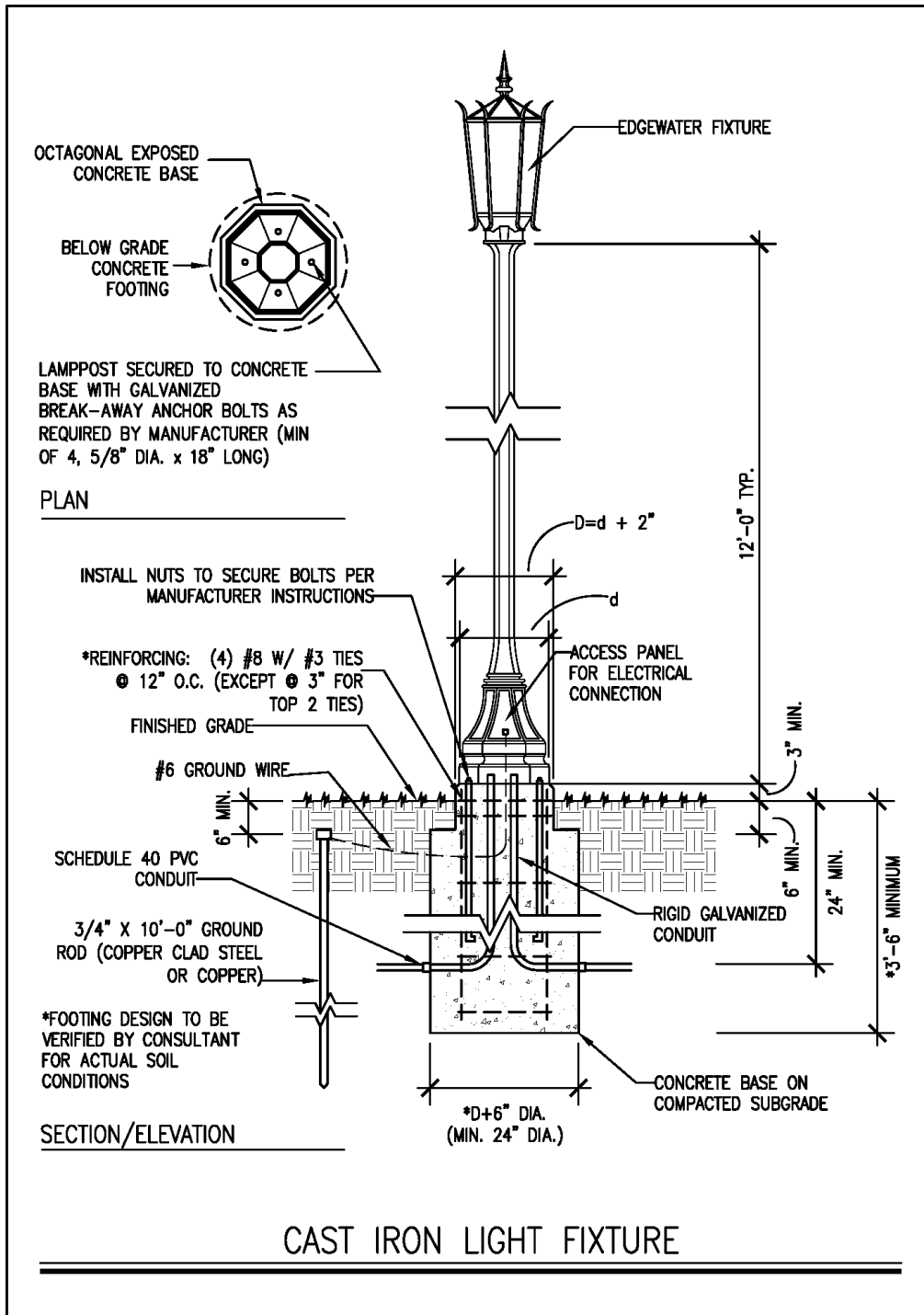

Figure 6: Cast Iron Light Fixture

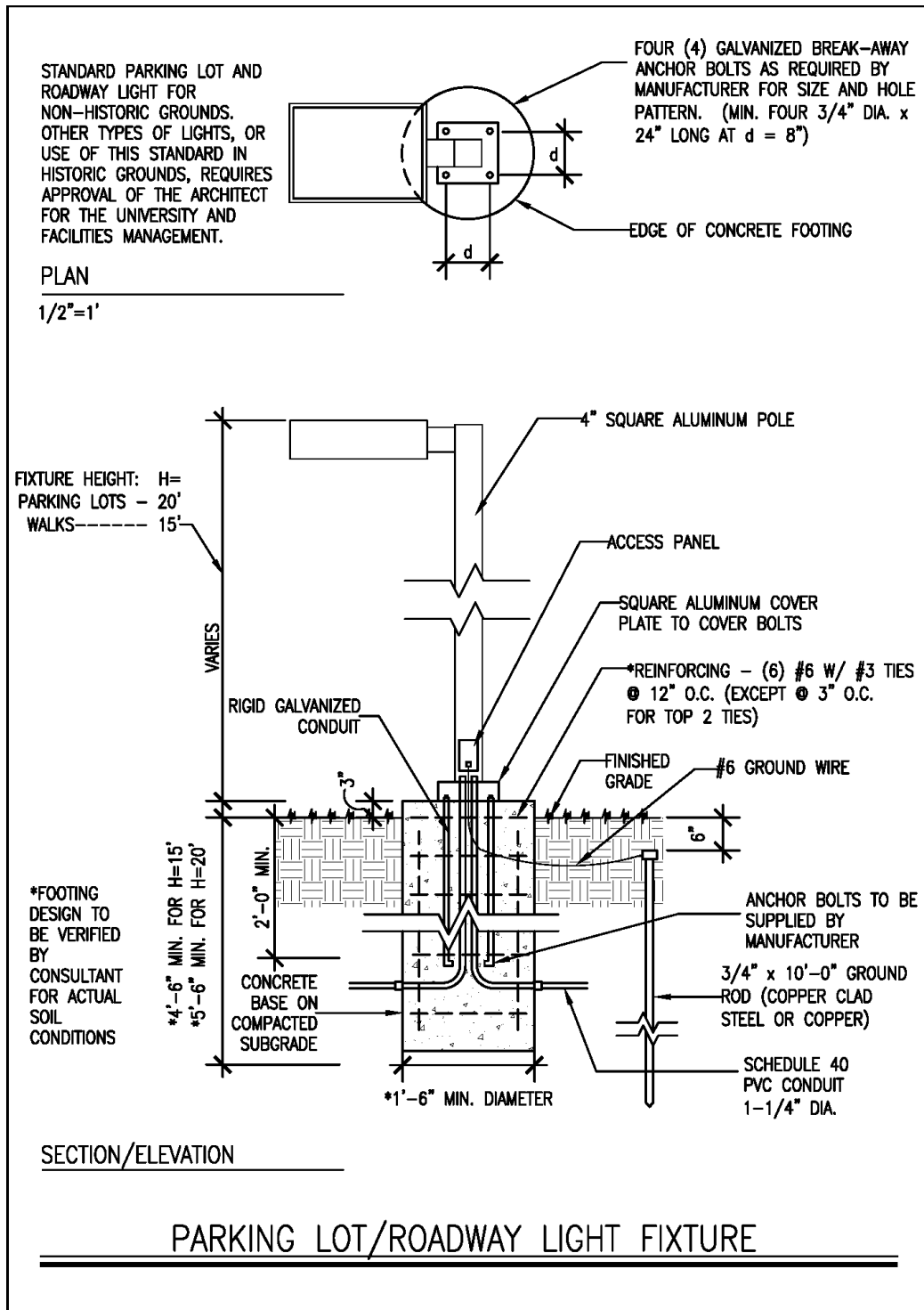

Figure 7: Parking Lot / Roadway Light Fixture

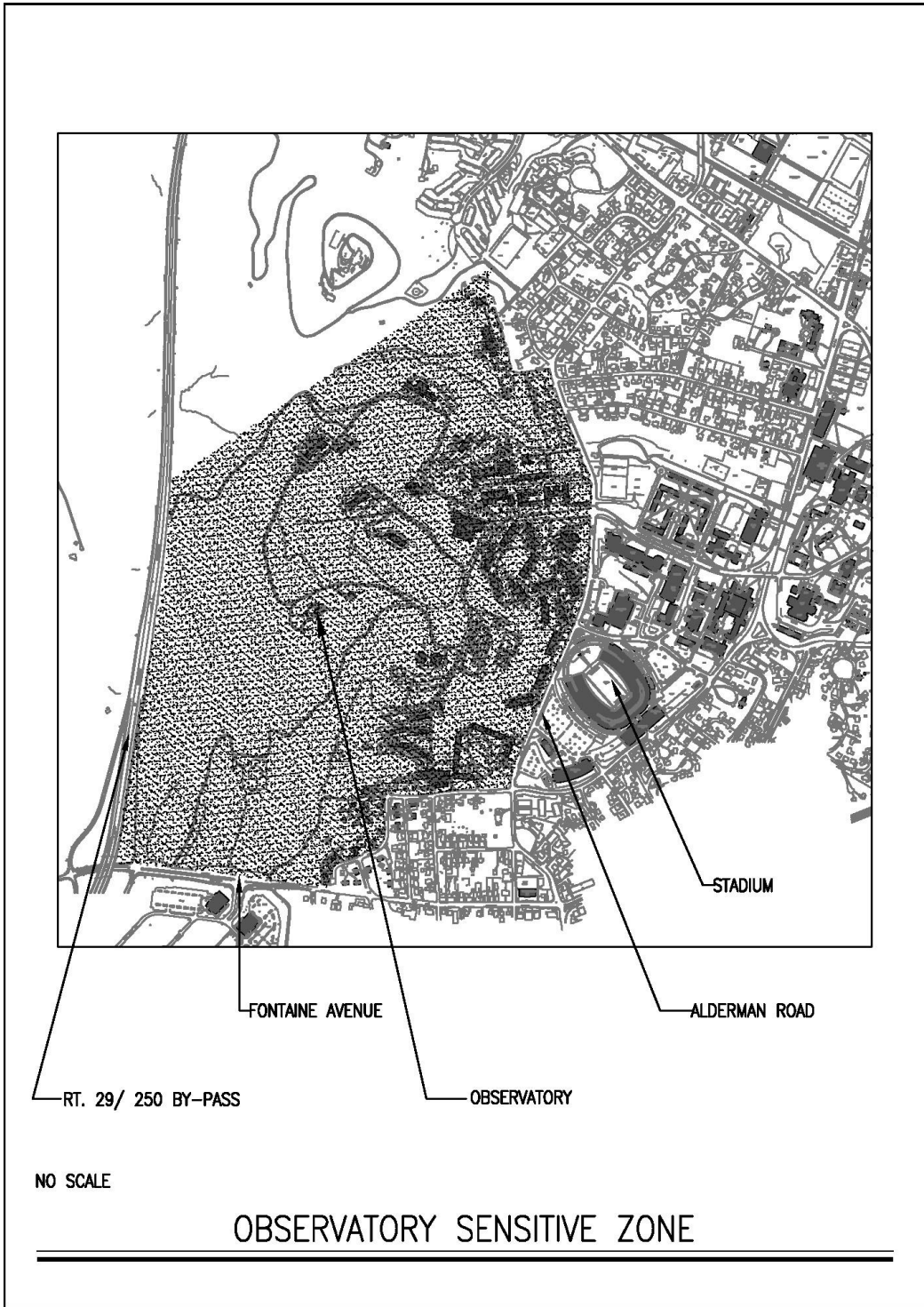
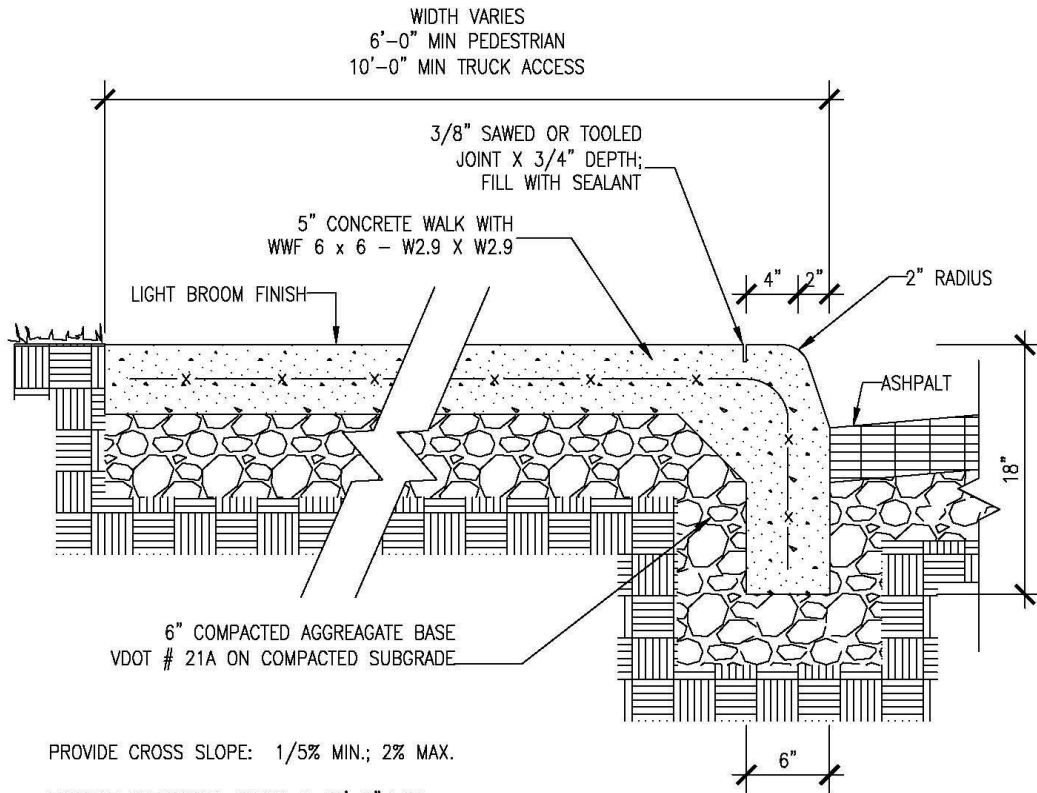

Figure 8: Observatory Sensitive Zone



PROVIDE CROSS SLOPE: 1/5% MIN.; 2% MAX.

PROVIDE EXPANSION JOINTS @ 30'-0" MAX

PROVIDE TOOLED OR SAWED JOINTS @ 6'-0" O.C. MAX

WHERE PERMITTED BY SITE LAYOUT, SEPARATE SIDEWALK FROM CURB WITH LANDSCAPE/GRASS FOR PEDESTRIAN SAFETY.

CONCRETE TO BE 3000 PSI AIR ENTRAINED

INTEGRAL CONCRETE SIDEWALK AND CURB

Figure 9: Integral Concrete Sidewalk and Curb

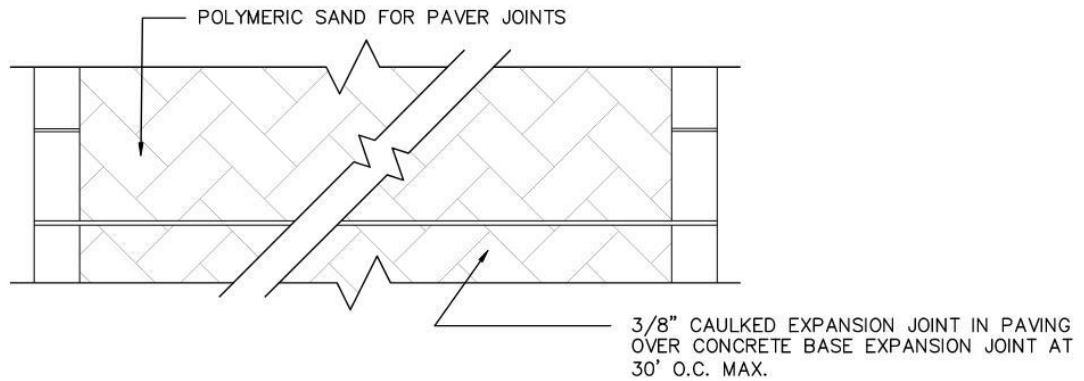

PLAN

* PROVIDE CROSS SLOPE: 1.5% MIN
2% MAX.

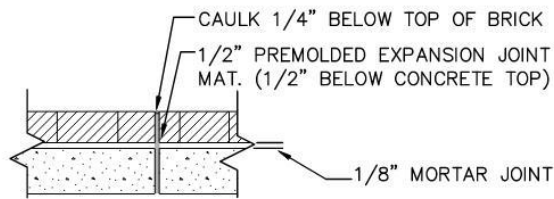

EXPANSION JOINT SECTION

GUIDELINES REGARDING THE SELECTION OF BRICK PATTERNS FOR WALLS AND PAVED AREAS SHALL BE BASED ON THE CURRENT EDITION OF THE OAU. LANDSCAPE TYPOLOGIES & STANDARDS. STANDARD BRICK PAVING PATTERN SHALL BE HERRINGBONE BUTT JOINTS WITH A STANDARD JOINT WIDTH OF 1/8". TYPICAL BRICK PAVING PATTERN IS HERRINGBONE WITH BUTT JOINTS (1/8" WIDTH JOINT), BORDER (EDGE) BRICKS SET WITH 3/8" FULL MORTAR JOINTS. (BRICK PATTERN TO BE DETERMINED AS DESIGN CRITERIA BY OFFICE OF THE ARCHITECT FOR THE UNIVERSITY, OAU.)

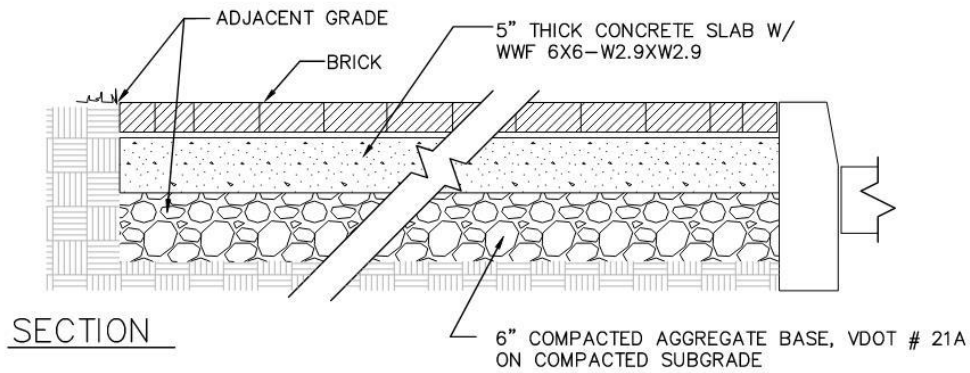

SECTION

BRICK WALK PAVING

Figure 10: Brick Walk Paving

INSIDE DESIGN CONDITION CRITERIA		
Occupancy/Use	Summer (Cooling) Occupied / Unoccupied	Winter (Heating) Occupied / Unoccupied
Offices/Classroom/ Lecture	74°F / 80°F	70°F / 62°F
Residential	74°F / 80°F	70°F / 62°F
Libraries *	74°F / 80°F	70°F / 62°F
Archival Storage in Libraries	Special	Special
Art Storage in Museums	Special	Special
IT/Telecom Rooms	80°F / 80°F	55° for freeze protection
Warehouse, Mechanical Rooms, Storage Rooms and Electrical Rooms	80°F / 80°F	55°F for freeze protection
Pools **	Special	Special
Hospitals	Consult the ASHRAE Guide or other applicable references	Consult the ASHRAE Guide or other applicable references
Laboratories (Educational/Research)	74°F / 80°F	70°F / 62°F
Gymnasiums/Recreation, Indoor Tennis and Racquetball Courts, Weight Rooms and Aerobic Rooms	72°F / 80°F	68°F / 62°F
Locker Rooms/Showers	76°F / 80°F	70°F / 62°F

Figure 11: Inside Design Condition Criteria

*Conditions may vary depending upon actual user justified requirements. Deviations must be approved by the CFO.

**Cooling for type occupancy/use must be justified to and approved by the CFO.

OUTSIDE DESIGN CONDITION CRITERIA Charlottesville, VA			
	Summer (Cooling)	Winter (Heating)	Evaporation
Drybulb	95°F	15°F	89°F
Wetbulb	76°F	-	79°F

Figure 11A: Outside Design Condition Criteria

The following table provides overall building supply and return water temperatures to which systems shall be designed. The designer shall make every effort to meet these design requirements, however, if not practical for equipment to obtain these values, a determination and findings is required.

BUILDING HEATING AND CHILLED WATER SUPPLY AND RETURN DESIGN WATER TEMPERATURES		
All buildings on Grounds		
	Supply	Return
Chilled Water	44°F	62°F
Heating Water	130°F *	100°F
Heating Water generated by Steam	160°F	130°F

Figure 11B: Building heating and chilled water supply and return design water temperatures

*The indicated temperature is for systems downstream of a low temperature heating water heat exchanger and may not apply to all projects. Verify heating water supply temperatures with Energy and Utilities.

PLANT HEATING SUPPLY AND RETURN DESIGN WATER TEMPERATURES		
	Supply **	Return **
Chilled Water Plants – CHW	42°F	62°F
Main Heating Plant – MTHW	170°F	140°F
Massie Road Plant	160°F	130°F
North Grounds Plant	140°F	110°F
Ivy Mountain Central Utility Plant	130°F	100°F

Figure 11C: Heating Plant supply and return design water temperatures

**The indicated temperatures are for peak conditions only. Verify design conditions with supply air temperature reset schedules.

COMPONENT COORDINATION (Scope of work/responsibility matrix)						
	Device	Furnished By	Installed By	Power Wiring	Control/ Interlock Wiring	Fire Alarm Wiring
	Air Handler Devices					
1	Duct Smoke Detectors	26 0000	23 0000	N/A (from FA system)	N/A	28 0000
2	Duct Smoke Detector Auxiliary Contents	26 0000	26 0000	26 0000	25 0000	28 0000
3	Smoke Dampers at AHU's	23 0000	23 0000	N/A	25 0000	N/A
4	Smoke Damper Actuators at AHU's	23 0000	23 0000	26 0000	25 0000	N/A
5	Fire Dampers	23 0000	23 0000	N/A	N/A	N/A
6	Air Flow Stations	25 0000	23 0000	N/A	25 0000	N/A
7	Automatic Control Dampers (unless specified with unit)	25 0000	23 0000	N/A	25 0000	N/A
8	Automatic Control Damper Actuators	25 0000	25 0000	25 0000	25 0000	N/A
9	Variable Speed Drives	23 0000 or 26 0000	26 0000	26 0000	25 0000	N/A
10	Humidifiers	23 0000	23 0000	26 0000	25 0000	N/A
11	Humidifier Control Valve	23 0000	23 0000	N/A	25 0000	N/A
12	Humidifier Isolation Valve	25 0000	23 0000	N/A	25 0000	N/A
13	Humidifier Airflow Switch	23 0000	23 0000	N/A	25 0000	N/A
	VAV and Terminal Units					
14	Supply & Exhaust Terminal Boxes (VAV's)	23 0000	23 0000	26 0000	25 0000	N/A
15	Terminal Flow Pick-up	23 0000	23 0000	N/A	23 0000	N/A
16	Terminal Damper Actuator (if not provided by box manufacturer)	25 0000	23 0000	N/A	25 0000	N/A
17	Terminal DDC Controller	25 0000	23 0000	26 0000	25 0000	N/A
18	Terminal Reheat Valves	25 0000	23 0000	N/A	25 0000	N/A
Continued on next page						

Continued from previous page						
	Laboratory Controls					
19	Supply, Hood Exhaust & General Exhaust Air Valves	25 0000	23 0000	N/A	25 0000	N/A
20	Controls at Fume Hood	25 0000	25 0000	26 0000	25 0000	N/A
21	Isolation Room Controls	25 0000	25 0000	26 0000	25 0000	N/A
	Meters					
22	Water Flow Meters	25 0000	23 0000	26 0000	25 0000	N/A
23	Electrical Demand Meters	26 0000	26 0000	26 0000	25 0000	N/A
24	Steam Flow Meters	25 0000	23 0000	26 0000	25 0000	N/A
	Digital Control Panels					
25	DDC Panels if shown on Electrical Drawings	25 0000	25 0000	26 0000	25 0000	N/A
26	DDC Panels if NOT shown on Electrical Drawings	25 0000	25 0000	26 0000 if 120V	25 0000	N/A
	Control Air					
27	Air Compressor	25 0000	23 0000	26 0000	N/A	N/A
28	Air Dryer	25 0000	25 0000	26 0000	N/A	N/A
	Water Systems					
29	Hydronic Control Valves	25 0000	23 0000	N/A	25 0000	N/A
30	Water Flow Switches for Chiller	23 0000	23 0000	26 0000	25 0000	N/A
31	Cooling Tower	23 0000	23 0000	26 0000	25 0000	N/A
	Miscellaneous Systems					
32	Refrigerant Monitoring	25 0000	25 0000	26 0000	25 0000	N/A
33	Split System (Heat Pumps, etc.)	23 0000	23 0000	26 0000	25 0000	N/A
34	Chemical Feed Systems	23 0000	23 0000	26 0000	25 0000	N/A
35	Kitchen Hood System	23 0000	23 0000	26 0000	26 0000 or 25 0000	28 0000

Figure 12: Component Coordination Matrix

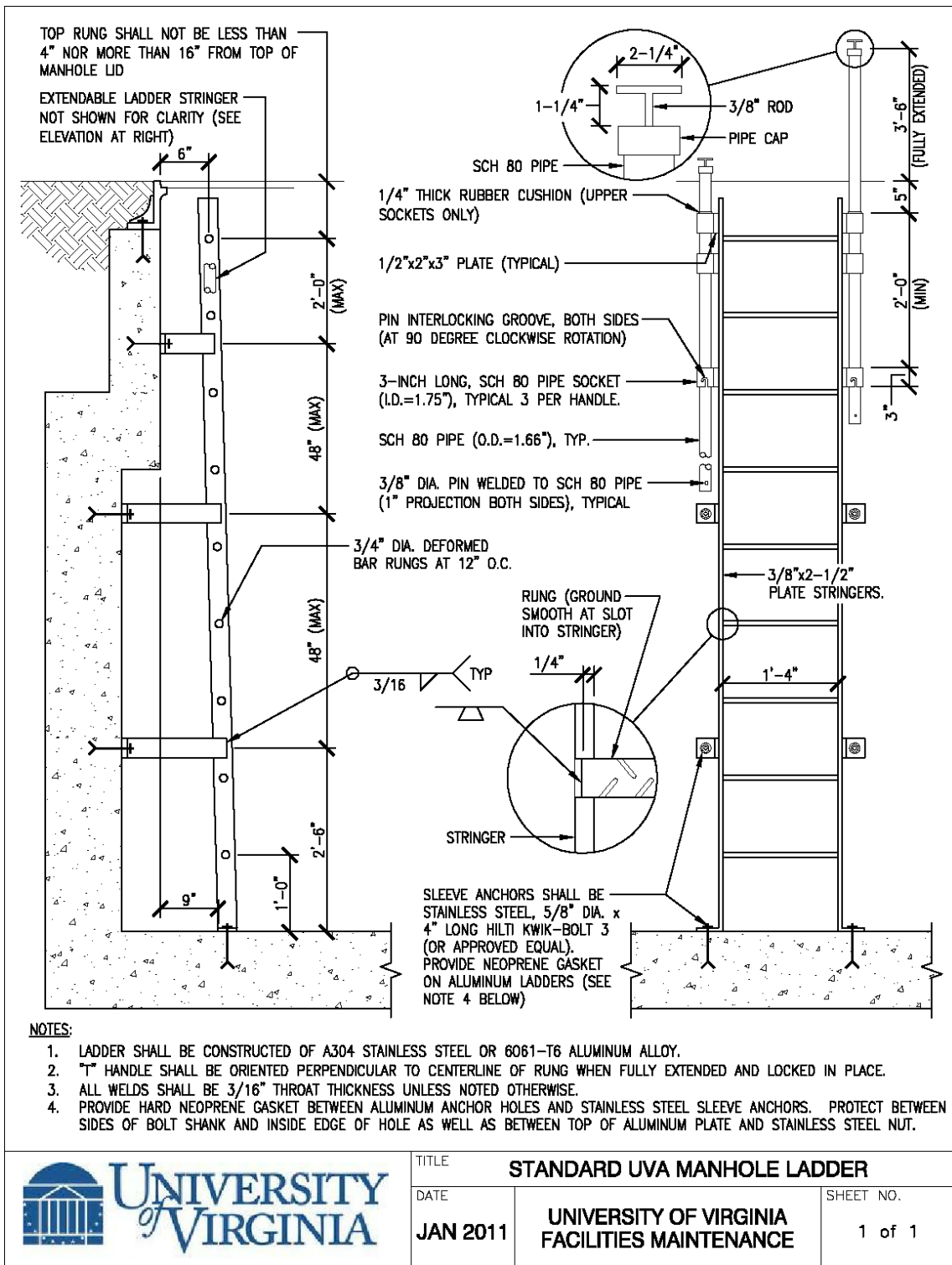

Figure 13: Standard UVA Vault Ladder for Steam Tunnels and Manholes Greater than 10' Deep [not required for Electrical manholes]

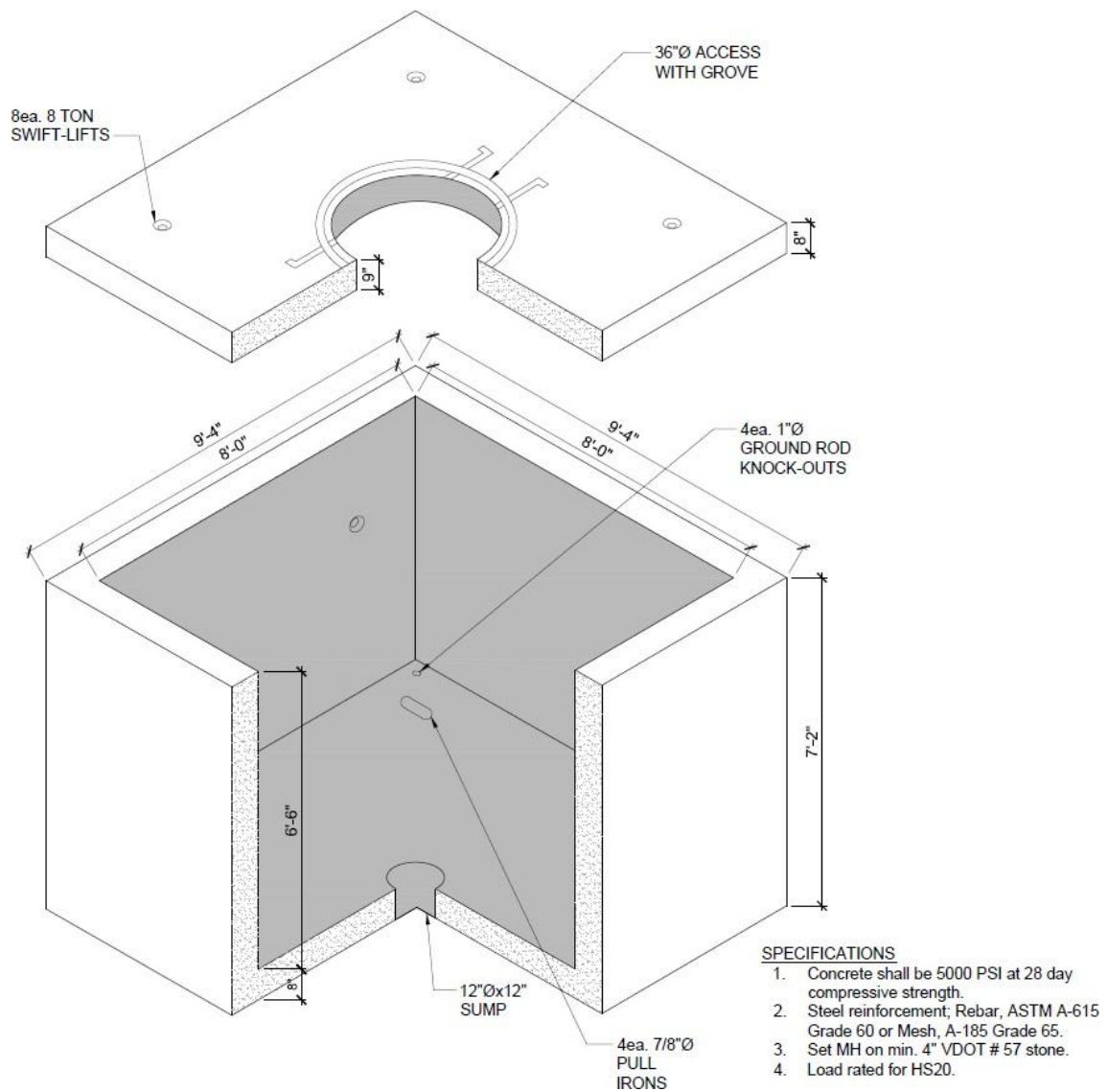

Figure 14: Electrical Manhole/Vault Detail

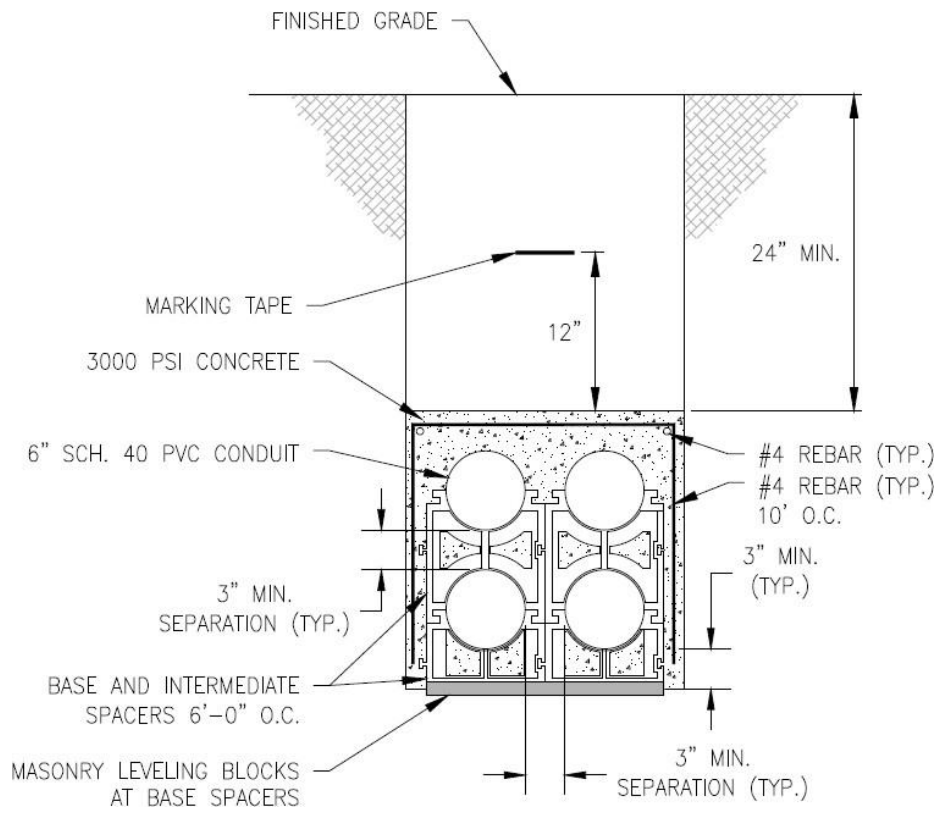

Figure 15: Electrical Ductbank Section

System/ Label	Abbreviation	PVC Wrap Color	Label Color
Chilled Water Supply	CHWS	BLUE	GREEN BACKGROUND, WHITE LETTERING
Chilled Water Return	CHWR		
Process Chilled Water Supply	PCHWS		
Process Chilled Water Return	PCHWR		
Cooling Coil Condensate	CCC	PURPLE	GREEN BACKGROUND, WHITE LETTERING
Medium Temperature Heating Water Supply	MTHWS	ORANGE	GREEN BACKGROUND, WHITE LETTERING
Medium Temperature Heating Water Return	MTHWR		
Low Temperature Heating Water Supply	LTHWS	YELLOW	GREEN BACKGROUND, WHITE LETTERING
Low Temperature Heating Water Return	LTHWR		
Steam	STM	BLACK	GREEN BACKGROUND, WHITE LETTERING
Domestic Cold Water	DCW	LIGHT BLUE	GREEN BACKGROUND, WHITE LETTERING
Domestic Hot Water	DHW		
Domestic Hot Water Return	DHWR		
Sanitary	SAN	NONE	GREEN BACKGROUND, WHITE LETTERING
Storm	STORM	NONE	GREEN BACKGROUND, WHITE LETTERING

Figure 16: Mechanical Room Piping Insulation Wrap and Labeling

APPENDIX B – Utility Metering Requirements

General

The contractor shall be responsible for proper installation of the meter per manufacturer’s guidelines and for enabling consumption calculations during construction before the utility service is turned on, unless waived by the Director of Energy & Utilities.

Temporary meters for construction use can be supplied by Metering staff without connection to the SCADA and will be read monthly. Portable metering needs to remain accessible when in service. The meter must be returned to Metering staff within 10 days of service disconnection or construction contractor will be billed for a replacement meter. Consumption during construction will use design maximum values when meter data is not available.

Electricity	
Application	<ul style="list-style-type: none"> • Electric Substations and Building Primary Electric Switchgear: <ul style="list-style-type: none"> ○ Power quality meters ○ For University substations, the highest level of power quality meters are required, typically including waveform capture and significant event storage capabilities • Building Electric Sub Meters <ul style="list-style-type: none"> ○ Energy meters • All Electric Meters: <ul style="list-style-type: none"> ○ Revenue-grade ○ MODBUS/Ethernet interfaces accessible via either <ul style="list-style-type: none"> ▪ Direct Ethernet connection or ▪ Local metering (Modbus) communications trunk • Local display of demand • Local display of totalized consumption
Connectivity	<ul style="list-style-type: none"> • Installations shall be digitally integrated into the SCADA system via MODBUS/Ethernet protocol over Ethernet. • Meters on building primary feeders will also be interfaced to the building automation system (BAS) for energy management use. This is accomplished by Metering staff using 3rd-party software and BACnet or OPC interfaces. • Minimum data to be mapped to the SCADA system: <ul style="list-style-type: none"> ○ Frequency ○ Apparent power, total and per-phase ○ Reactive power, total and per-phase ○ Real power (kW), total and per-phase ○ Energy (kWh) ○ Voltage, per phase and 3-phase avg (L-L and L-N) ○ Current, per phase and 3-phase avg ○ Total harmonic distortion (voltage and current) if meter is capable

Compatible Meters	<p>Advanced Power Quality Meters:</p> <ul style="list-style-type: none"> • Schneider Electric PM8000 • Schneider Electric ION7400 • Schneider Electric ION8650 • Schneider Electric ION7550/7650 • Schneider Electric ION9000 <p>Energy Meters:</p> <ul style="list-style-type: none"> • Power Logic PM5000 series • ION 6200 <p>Multi-circuit Power and Energy Meters Sub-metering:</p> <ul style="list-style-type: none"> • PowerLogic PM3000 • PowerLogic PM3500 • Power Logic EM4800 • Power Logic EM4900
-------------------	--

Domestic Water	
Application	<ul style="list-style-type: none"> • Low Consumption Domestic Water Meters: <ul style="list-style-type: none"> ○ Deemed “low consumption” by the University Metering staff ○ Shall be turbine, positive displacement, or ultrasonic • Domestic Water Meters (not low consumption): <ul style="list-style-type: none"> ○ Need to meet Federal and State guidelines for meter liners on all services • All Domestic Water Meters must have: <ul style="list-style-type: none"> ○ Local display of volumetric flow rate ○ Local display of totalized consumption
Connectivity	<ul style="list-style-type: none"> • Installations shall be digitally integrated into the SCADA system via Modbus/Ethernet protocol. • Totalization, volumetric flow rate, and diagnostic data shall be mapped into the SCADA.
Compatible Meters	<p>Magnetic flowmeters:</p> <ul style="list-style-type: none"> • Toshiba LF & GF series • Endress + Hauser Proline • Badger ModMag <p>Ultrasonic flow:</p> <ul style="list-style-type: none"> • Flexim Fluxus series

Chilled Water & Heating Hot Water	
Application	<ul style="list-style-type: none"> • Chilled/Hot Water Meter Placement: <ul style="list-style-type: none"> ○ 10 unobstructed pipe diameters of straight pipe upstream AND ○ 5 unobstructed pipe diameters of straight pipe downstream • Chilled/Hot Water Pipe Sizes from 1” to 48”: <ul style="list-style-type: none"> ○ Ultrasonic energy BTU meters

	<ul style="list-style-type: none"> ○ Matched RTD strap-on temperature sensors required • BAS or Industrial Control of Chillers and Boilers: <ul style="list-style-type: none"> ○ Separate magnetic flow meters (in addition to energy meters & temperature sensors as stated above) ○ The use of Magnetic flow meters for thermal energy will require an Energy Flow computer • All Chilled/Hot Water Meters: <ul style="list-style-type: none"> ○ Local display of energy demand ○ Local display of volumetric flow rate ○ Local display of totalized energy consumption
Connectivity	<ul style="list-style-type: none"> • All installations shall be digitally integrated into the SCADA via Modbus/Ethernet protocol. • Minimum data to be mapped into the SCADA <ul style="list-style-type: none"> ○ Totalization ○ Energy ○ Linear flow rate ○ Volumetric flow rate ○ Supply temperature ○ Return temperature ○ Diagnostic data • Meter shall calculate and display energy consumption without SCADA support.
Compatible Meters	<p>Ultrasonic Energy BTU Meters:</p> <ul style="list-style-type: none"> • Flexim Fluxus Thermal Energy series <p>Ultrasonic Flow Meters:</p> <ul style="list-style-type: none"> • Flexim FLUXUS series • See magnetic flow meters above in water section

Steam	
Application	<ul style="list-style-type: none"> • Steam Meter Placement: <ul style="list-style-type: none"> ○ 10 unobstructed pipe diameters of straight pipe upstream AND ○ 5 unobstructed pipe diameters of straight pipe downstream • Steam Services > 8": <ul style="list-style-type: none"> ○ Insertion turbine meters OR ○ Vortex shedding meters • Steam Services <= 8": <ul style="list-style-type: none"> ○ Spring-loaded, variable area meters • Steam Condensate: <ul style="list-style-type: none"> ○ Ultrasonic flow meter w/ transducer RTD built in ○ Must be approved by Metering staff when a steam flow meter cannot be installed

	<ul style="list-style-type: none"> • All Steam Meters: <ul style="list-style-type: none"> • Local display of demand • Local display of totalized consumption • Local display of compensation input values where applicable
Connectivity	<ul style="list-style-type: none"> • All installations shall be digitally integrated into the SCADA via Modbus/Ethernet protocol. • Minimum data to be mapped into the SCADA <ul style="list-style-type: none"> ○ Totalization ○ Flow rate ○ Diagnostic data • Steam meters shall calculate and display energy or mass flow rate demand and total consumption without SCADA support. • Condensate meters shall calculate and display volumetric flow demand and consumption. • Steam meter installations that require a flow computer for compensation calculations shall integrate the computer with the SCADA via the Modbus/Ethernet connection.
Compatible Meters	<p>Spring-Loaded Variable Area Meters:</p> <ul style="list-style-type: none"> • Spirax Sarco Gilflo, ILVA, w/ Scanner 2000 DP: (Energy flow computer KEP • SuperTROL or Spirax Sarco M850) • Spirax Sarco TVA series • Vortek VorCone <p>Turbine / Vortex meters:</p> <ul style="list-style-type: none"> • Spirax Sarco RIM20 • Spirax-Sarco VIM20 • Vortek Turbo Pro VTP • Vortek Turbo Pro V • Azbil AX2200 / AX2300

Oil	
Application	<ul style="list-style-type: none"> • All Oil Meters: <ul style="list-style-type: none"> ○ Ultrasonic, or Teflon lined magnetic flow meters ○ Local display of demand ○ Local display of totalized consumption
Connectivity	<ul style="list-style-type: none"> • Installations shall be digitally integrated into the SCADA via Modbus/Ethernet protocol. • Minimum data to be mapped into the SCADA <ul style="list-style-type: none"> • Totalization • Volumetric flow rate • Diagnostic data

Compatible Meters	Ultrasonic Flow Meters: <ul style="list-style-type: none"> • Flexim Fluxus series Magnetic Flow Meters: <ul style="list-style-type: none"> • See magnetic flow meters above in water section
-------------------	--

Natural Gas	
Application	<ul style="list-style-type: none"> • All Natural Gas Meters: <ul style="list-style-type: none"> ○ Thermal Mass flowmeters ○ Local display of demand ○ Local display of totalized consumption
Connectivity	<ul style="list-style-type: none"> • Installations shall be digitally integrated into the SCADA via Modbus/Ethernet protocol. • Totalization, volumetric flow rate, and diagnostic data shall be mapped into the SCADA.
Compatible Meters	Thermal mass flowmeters: <ul style="list-style-type: none"> • Spirax Sarco MT110 / MTL10 • Sierra BoilerTrak

APPENDIX C – Elevators

This section of the UDG is maintained online. See the OUBO website (<https://oubo.virginia.edu/udg.html>) for current requirements and details.

APPENDIX D – Not Used

APPENDIX E – Not Used

APPENDIX F – Locksets & Access Control

This section of the UDG is maintained online. See the OUBO website (<https://oubo.virginia.edu/udg.html>) for current requirements and details.